



HISTORIC DISTRICT COMMISSION ADDITIONAL INFORMATION REQUEST

City of Detroit - Planning & Development Department
2 Woodward Avenue, Suite 808
Detroit, Michigan 48226

Date: 4/15/26

Application Number: HDC2026-00162

APPLICANT & PROPERTY INFORMATION

NAME: Kahlil Assad		COMPANY NAME: 470 MLK BLVD LLC	
ADDRESS: 1925 Forest Lane	CITY: Bloomfield TWP	STATE: MI	ZIP: 48301
PROJECT ADDRESS: 470 Martin Luther King Jr Blvd			
HISTORIC DISTRICT: Willis-Selden			

REQUESTED INFORMATION

We have received your application, but it is not yet complete for review. Please provide additional details based on the comments and questions listed below. Should you need to attach additional files per this request, use the paperclip icons at the end of this form. You may attach up to (5) files per icon up to 25MB:

This application is not yet complete. Please provide:

- Current photos showing complete sides (all sides/walls) of building, including all walls of each window well/courtyard.
- Diagram/photo labeled showing all historic windows remaining, and each remaining historic window needs a unique identifier/label. (The provided window types are not specific enough for the Commission to determine whether the remaining historic windows are beyond repair. Instead, each remaining historic window needs its own number.)
- Detailed interior and exterior photos of each historic window remaining showing window conditions, labeled/captioned coordinating with the labeled diagram or photo.
- Measurements of each window component for the remaining historic windows (see attached measurement guide)
- Coordinating measurements of each window component for the proposed replacement windows (in order to compare how close a match the replacement is for the historic)
- Clear specs and images for the proposed replacements. Some of the spec details are in Chinese, and some images provided for the various window series (83, E2, etc) are blurry.
- Interior and exterior photos of all existing doors to be replaced. (These must be detailed enough to show conditions.)
- Product cut sheets/specs for proposed replacement doors.

The historic district commission will need to review this application. They will apply the Secretary of the Interior's Standards for Rehabilitation, which emphasize preservation of historic materials and which require that historic materials be preserved unless they are beyond repair. Then, the Standards require that the replacements for those historic features, like historic windows and doors, match the historic in design, color, texture, materials if possible, and other visual qualities. Please see the attached materials. Thank you.



PSR: Ellen

260415et

APPLICANT RESPONSE

Response Date: 04/17/2026



The reason we are seeking to replace the original windows is because they were irreparable. The original windows were blighted; missing glass panels entirely, missing, fractured, broken and/or rotted wooden frames, resulting in additional damage to windows and surrounding walls caused by elemental sources (water damage caused by rain or snow and cold air entering from openings). The state of the original windows was not weather-proof, and their blighted condition was not only unsalvageable but also posed as a safety hazard.

The original doors had broken hinges, broken glass and also was subject to additional damage from the elements (same as the windows). The weight of the doors, along with the broken glass and hinges, resulted in the doors becoming a safety hazard and irreparable.

For the reasons above, the decision to replace the windows entirely with updated fixtures that aligned with were within an appropriate color palette of the building and was close enough in design to try to preserve the historic appearance of the building.

Due to the size of the building, we are limited to the amount of photos we can provide for this application. Should you wish to have additional photos to support this application, please contact dalexander@theairking.com and more photos will be provided.

Guidelines for Historic Wood Windows

Detroit Historic District Commission

Repair is the First Option for Historic Wood Windows

The Detroit Historic District Commission (HDC) follows the Secretary of Interior Standards for Rehabilitation for historic properties www.nps.gov/subjects/taxincentives/secretarys-standards-rehabilitation.htm. Accessed 9 Jan. 2024..

For historic windows, Standard 6 is most directly applicable:

Standard 6. Deteriorated historic features will be repaired rather than replaced. Where the severity of deterioration requires replacement of a distinctive feature, the new feature will match the old in design, color, texture and, where possible, materials. Replacement of missing features will be substantiated by documentary and physical evidence.

The central message of the Standards is that historic windows will be repaired rather than replaced. Only when a window has severely deteriorated, and it cannot be repaired, may it be replaced. Generally, even badly deteriorated windows can be repaired by crafts persons who know about historic windows. The standard for replacement windows is strict.

"I've assessed the condition of more than a thousand [sashes], and never seen a sash that could not be repaired." John Leeke (well-known window contractor), Historic Home Works

The Standards for Rehabilitation are from the Secretary of the Interior, National Park Service.¹ The HDC is required to follow these Standards by the Detroit City Ordinance for historic districts.²

Standard 2 also applies directly, because historic windows are a defining characteristic of historic buildings.

Standard 2. The historic character of a property will be retained and preserved. The removal of distinctive materials or alteration of features, spaces and spatial relationships that characterize a property will be avoided.

Other Standards also relate to windows less directly.

¹ "The Secretary of the Interior's Standards for Rehabilitation." National Parks Service, U.S. Department of the Interior, www.nps.gov/subjects/taxincentives/secretarys-standards-rehabilitation.htm. Accessed 9 Jan. 2024.

² "2019 Detroit City Code, Sec. 21-2-73. - Issuance of Certificate of Appropriateness." Municode Library, library.municode.com/mi/detroit/codes/code_of_ordinances?nodeId=CICOCH21--43_CH21HI_ARTIIHIDILA_DIV4PEWOWIDI_S21-2-73ISCEAP. Accessed 9 Jan. 2024.

What Constitutes Repair of an Historic Wood Windows.

The principal objective of the Standards for Rehabilitation is to preserve historic properties and their features for the future. For historic windows to be preserved, they must be kept in good repair. Most of all, preservation requires regular maintenance. When a portion of a window has deteriorated, due to lack of maintenance or damage, it must be repaired sufficiently to assure its survival.

A historic window that is preserved for the future will have these characteristics:

1. No broken or cracked panes of glass.
2. Glazing putty on the exterior is intact and painted.
3. Paint is intact, with no flaking paint.
4. Wood windowsills are intact and painted.
5. All components of the window sash are intact and painted.
6. Any missing sash (upper, lower, or both) is replaced to match the originals closely.
7. The window jambs, brickmould, head, and casing are intact and painted.
8. Caulking **in** between brick molds and casings to prevent moisture incursion.
9. Any window that must be opened is operable: lower sash can move up and down; casement windows can swing open.

Operability is not a required condition for a fully repaired window. For example, upper sash rarely are opened and do not need to be operable. Other windows that are not opened do not need to be operable.

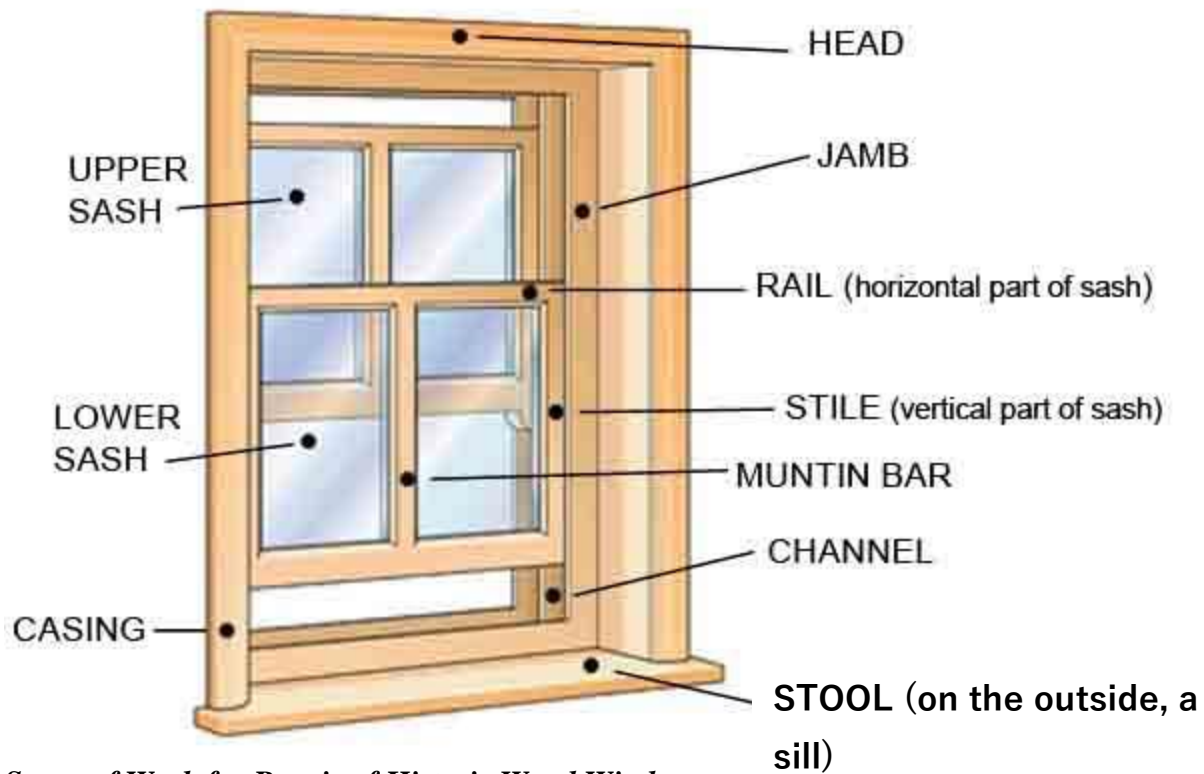

Scope of Work for Repair of Historic Wood Windows

A historic wood window that lacks any of these characteristics will need to be repaired to preserve it into the future. Often the repairs are just elements of deferred maintenance.

The Scope of Work for repair is for individual windows. The Scope of Work will include just the minimum repairs necessary for the window to have all of the characteristics of a historic window preserved into the future.

On most buildings, many windows are likely to be in good repair and require little or no repair. For example, upper sash often need little repair. Some windows may need extensive repair work; lower sash and windowsills often need repair.

These repairs may be necessary to rehabilitate an individual window:

1. Broken or cracked panes of glass must be replaced.
2. Glazing putty at panes of glass on the exterior must be intact to protect the window. Intact glazing can be left in place; missing or deteriorated glazing must be replaced.
3. If there is flaking paint or bare wood, it must be scraped or sanded to prepare for primer and final coats of paint to protect the window.
4. Wood windowsills must be stabilized or repaired and sealed with primer and final coats of paint; if severely deteriorated, wood sills can be replaced in kind. Sills must slope away from the window to drain water.
5. If a sash has a deteriorated component (rail, stile, or muntin), that component must be stabilized or repaired sufficiently to preserve the window. Individual elements can be replaced in kind.
6. If a sash is missing or unrepairable, a new sash can replace the missing sash; the new sash must match the original sash closely.
7. If the window jambs, brickmould, head, and casing are deteriorated or damaged, they must be repaired or replaced in kind.

Prioritize Repairs

Some window repairs can have higher priorities than others. Spreading out the repair over time also spreads out the expense, which may be more manageable, if funds or financing are not available to do all repairs at one time.

1. Window Usage

In most buildings, occupants open some windows and not others. Windows that are the most important to be opened can have higher priority and be repaired first. For windows that are never opened, repairs can be deferred. Upper sash rarely are opened - only lower sash may need repair. Even if an unused window needs substantial repair, if it is covered by a storm window, that protection can allow deferral of the repair, perhaps for many years; in this way, a window is "mothballed" for future repair.

2. Window Conditions

For most buildings, the conditions of windows will vary. Some will be in good repair. Often upper sashes in double-hung windows get little wear and are in good condition. Some windows may need extensive repairs, including replacement of some components. And some will need small repairs. Windows that need the most repair can have higher priority to be repaired.

Beyond Repair

Full Restoration

Historic windows can be restored close to their original condition. While such a restoration to a “like new” condition is an ultimate goal, this goes beyond the repair necessary to preserve windows into the future, until a fuller restoration is possible.

A brief scope of work for a more extensive restoration is below. A full restoration may require that the window be disassembled.

1. Necessary repairs are, of course, the first step in a full restoration.
2. Paint or finish build-up (both exterior and interior) can be removed and replaced with fresh finishes. Interior finishes often are other than paint: they may not have as much build-up and can be refreshed rather than removed. As old paint may be lead-based, caution is required and safety steps must be implemented.
3. Glass can be fully reglazed.
 - a. Most simply, all glazing putty can be removed and replaced.
 - b. Further, glass panes can be removed from their beds (glazing rabbets), the beds cleaned, a thin layer of glazing compound applied to the beds, and the glass reset and reglazed.
4. Window hardware can be thoroughly cleaned and lubricated, or perhaps replaced to match the original.
5. On double-hung windows, sash ropes can be replaced, and pulleys can be lubricated or replaced.
6. New weather stripping can be added as needed.

Weatherization

A historic wood window that is in good repair also can be weatherized to reduce heat loss. Weatherization blocks cold air infiltration and prevents the escape of warm air. Energy also is lost through heat conduction through glass, which weatherization can reduce. In addition, weatherization measures also can reduce moisture infiltration that damages window structures.

The most effective weatherization is a tight-fitting storm window.

1. If exterior storms exist, they can be updated with new stripping and brush seals or rubber seals, and latches lubricated or replaced. Replace any broken glass.
2. Replace any missing glass and screen panels.
3. If there are no storms, there are both exterior and interior storm window options.

4. For exterior storms, caulking around the edges will reduce air infiltration and tighten the air space to reduce convection. However, do not caulk the bottom edge of storms, as this leaves a space for moisture to escape.
5. Exterior storms also protect windows from deterioration from weathering.

Storm windows and tightly weatherized sash create a large dead air pocket, which is an insulator. This is the same principle of insulation as a modern double-paned window sash, but with a much larger dead air space.

Several additional weatherization steps include:

1. Caulk around the exterior of windows where the jambs, brickmould and casing join the house. Heads and sills should not be caulked: open spaces allow moisture to escape.
2. On the interior, any space between interior casing and plaster walls can be sealed with spackling.
3. Weatherstripping on the interior between sash and jamb, using inexpensive weather stripping.
4. Sash locks in good repair (or replaced) keep the upper and lower sash tightly sealed.

Window Replacement

When a historic window is missing, it can be replaced. Also, when a window is so deteriorated or damaged that repair is either technically not feasible or economically not reasonable, it can be replaced.

For economic reasonableness, the cost of repair that is relevant is the cost of the scope of repair, as delineated above. While a full restoration will have higher cost, that is not the relevant cost to consider with respect to window replacement.

What is a reasonable cost of repairing a window is contingent on the importance of the window. In a building, a window or set of windows may be so important to the architectural design of the building that they need to be repaired even at a fairly high cost rather than replaced. For example, a large leaded-glass window in a prominent location may be crucial to the character of a building.

Replacement windows must conform to conditions specified in Standard #6: *the new feature will match the old in design, color, texture and, where possible, materials.*

1. New windows must match the original windows in operation: most often windows are fixed panes, double-hung, or casement. There are other types.
2. The pattern of lites (panes) in the window must match that in the original window. For example, if an upper sash has 6 lites and the lower sash has only one, then the new windows must have the same configuration. There are many different configurations of lites observed in historic windows. Often these are highly distinctive configurations that are integral to the architecture of the building.
3. The dimensions of the window components (the rails, stiles, and muntins) should match or be very close to the dimensions of the components of the original window.

4. Multipaned windows must be replaced with either true divided lite windows or windows with simulated divided lites. Faux muntins between the glass panes of double-glazed window glass do not provide the same shadow lines and depth as historic windows and are inappropriate.
5. The color of the new windows must be within the color palette appropriate for the architectural style of the building.
6. The material of new windows should be the same as the original windows or be reasonably close in appearance.

ADOPTED BY THE DETROIT HISTORIC DISTRICT COMMISSION MARCH 13, 2024

The Detroit Historic District Commission (HDC) follows the Secretary of Interior Standards for Rehabilitation for historic properties. For historic windows, Standard 6 is most directly applicable: *Deteriorated historic features will be repaired rather than replaced. Where the severity of deterioration requires replacement of a distinctive feature, the new feature will match the old in design, color, texture and, where possible, materials. Replacement of missing features will be substantiated by documentary and physical evidence.*

The central message of the Standards is that historic windows will be repaired rather than replaced. Only when a window has severely deteriorated, and it cannot be repaired, may it be replaced. Generally, even badly deteriorated windows can be repaired by people who have experience working with historic wood building components. Attached to this email is the Commission's *Guidelines for Historic Windows* that goes into greater detail on the retention, repair and potential replacement of historic windows.

The Historic District Commission Staff can administratively review a proposal to retain and repair existing historic windows.

WINDOW REPLACEMENT APPLICATION OF ORIGINAL WINDOWS

If you move forward with an application to replace historic windows, the following information is needed. It is the applicant's responsibility to discuss, in words and pictures, existing conditions of the windows proposed for replacement and supply the details of the selected replacement window.

- Scope of work
 - List the number of windows to be replaced, the description of the existing windows (i.e., steel casement, wood double-hung, etc.) and their location(s) on the building.
- Photo documentation
 - Exterior photo(s) of each side of the building where windows are proposed to be replaced (always include one photo of the front of the house, even if no windows are proposed for replacement at this location). Identify each photo as front, left side, right side, and/or rear.
Photos must clearly show each window opening that is proposed for replacement.
 - Submit multiple photos of the sides of the house, if needed, so all windows are clearly shown.
 - If windows are boarded over, or storm windows cover the window frames, take photos from the inside of the building so the condition of the windows are visible.
 - Each window included in the proposal must be identified by a consecutive number or letter; please do not start numbers over on each side of the building. Using numbers that are listed on a window order (if you already have one) can also be used.
- Existing window documentation
 - Describe condition/problems of existing windows and submit measurements of window frames and muntins/grilles (if present). Page 2 of this document can be used to complete this requirement.
- Replacement Windows
 - Identify the manufacturer and line of replacement windows.
 - Submit manufacturer cut sheets that confirm exterior window frame material, color, grilles (if proposed), window glass and screen specifications, and dimensioned section drawings that list the measurements for the proposed window frames. Pages 3 & 4 of this document offer visual aid in the information needed for this application.

You can also provide further information/details to outline your decision-making process re: the replacement of the windows, which may include the following:

- Description of repair work that has been completed (if any) on the windows since owning the structure.
- Recent efforts to repair windows (if any)
- Copies of obtained estimates to repair the existing windows. If repair estimates were not obtained, list the reasons why.
- Description on why you are seeking to replace the windows vs repairing them
- Any additional details which you deem to be pertinent/you would like the Commission to review with respect to the replacement of the windows

Dimensions of existing windows

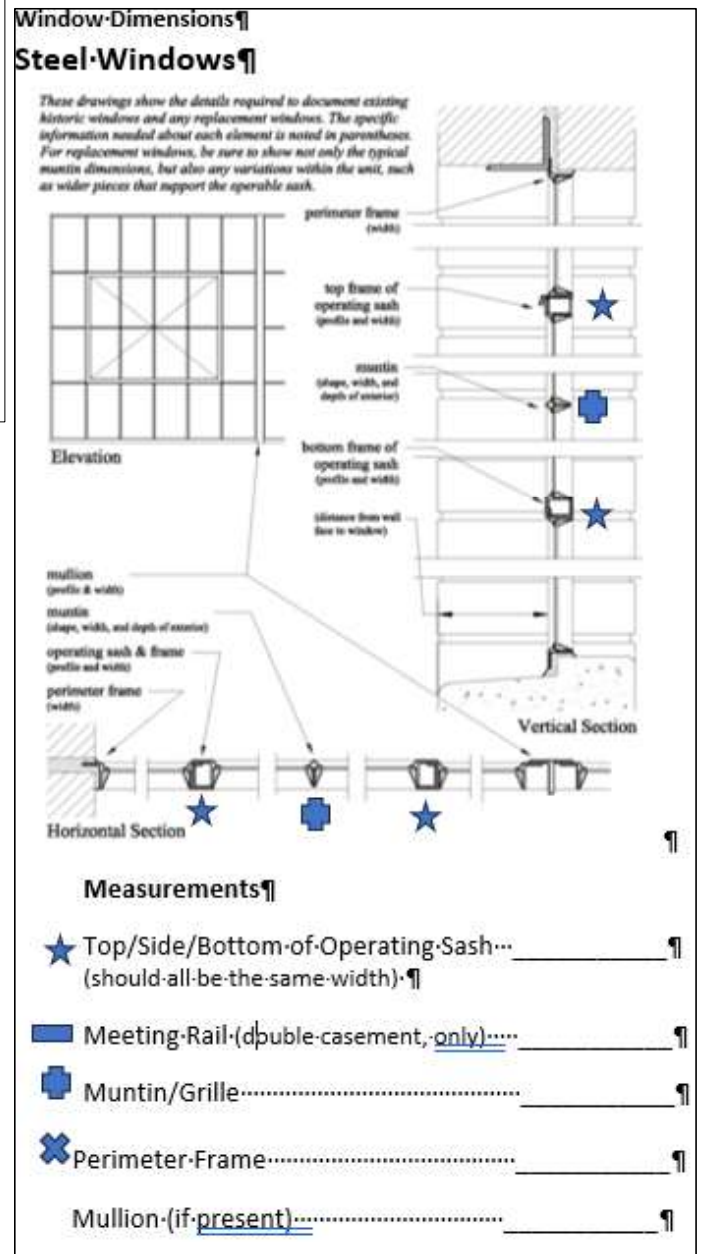
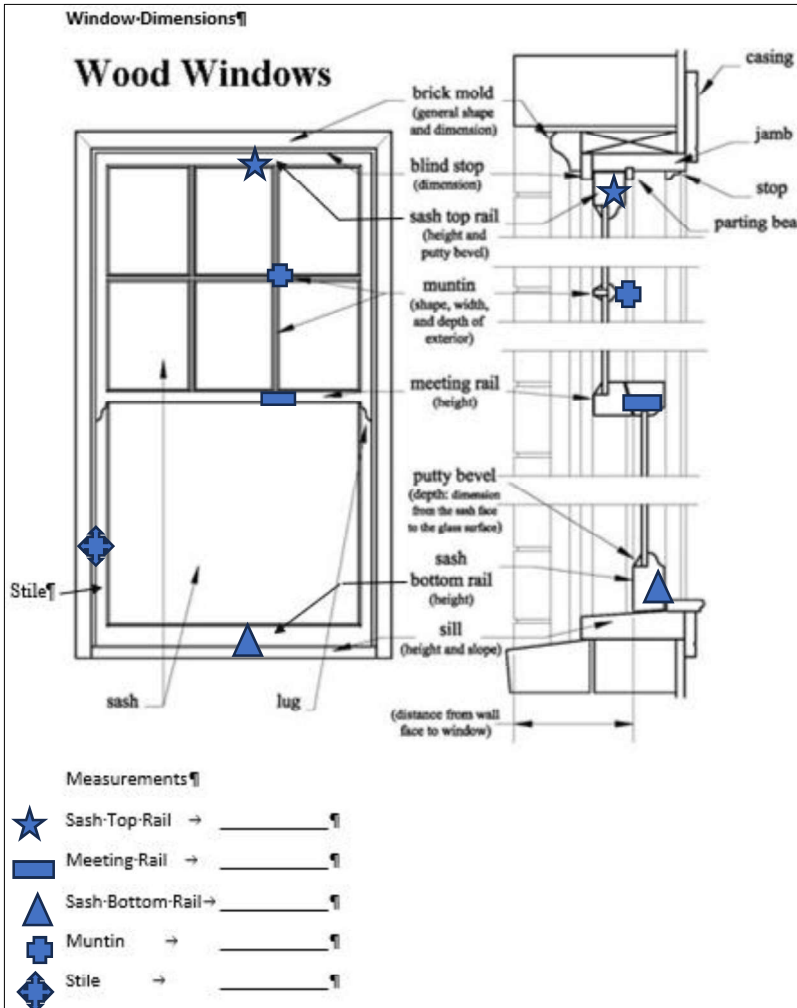

Proposed Replacement Windows

Brochure/Cut Sheets

- Submit copies of the individual pages that confirm the material, operation, frame design, grilles (if applicable) and finishes (glass, screens, etc.).

Exterior frame and selected cladding color



EXTERIOR COLORS



Grilles



Glass options



Window sections for proposed replacement windows – Depending on the window manufacturer, these sections can be difficult to find on the company’s website. You may need to ask your window representative for the sections. Dimensioned sections of the selected replacement window must be included in the application.

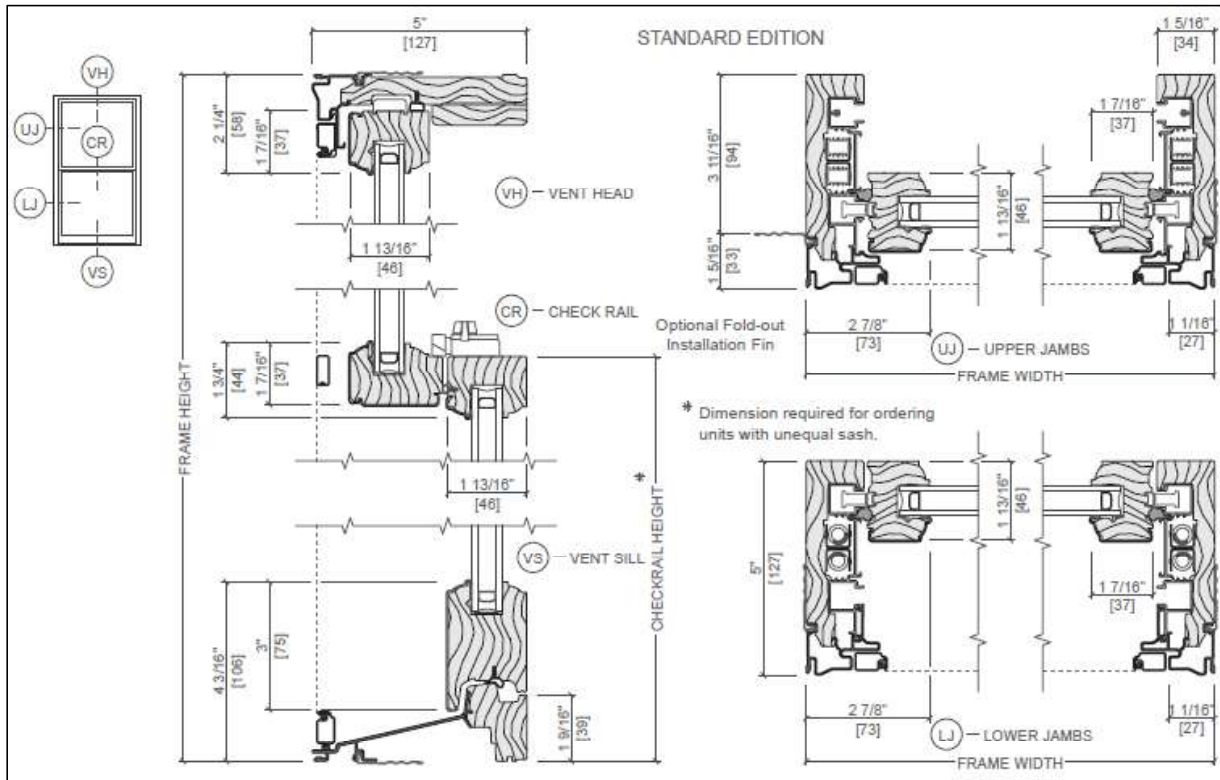































66 67 68 69 70 71 72 73 74 75 76 77 78 79 80 81 82 83 84 85 86























King's Arms Hotel
MONTHLY WEEKLY DAILY

419



King
BUILDING & REPAIR

112



King's Arms Hotel
MONTHLY WEEKLY DAILY













470





























