



HISTORIC DISTRICT COMMISSION ADDITIONAL INFORMATION REQUEST

City of Detroit - Planning & Development Department
2 Woodward Avenue, Suite 808
Detroit, Michigan 48226

Date: 3/17/2026

Application Number: HDC2026-00106

APPLICANT & PROPERTY INFORMATION

NAME: John Biggar		COMPANY NAME: studiozONE	
ADDRESS: 350 MADISON ST FL 4TH	CITY: DETROIT	STATE: MI	ZIP: 48226
PROJECT ADDRESS: 264 Watson			
HISTORIC DISTRICT: Brush Park			

REQUESTED INFORMATION

We have received your application, but it is not yet complete for review. Please provide additional details based on the comments and questions listed below. Should you need to attach additional files per this request, use the paperclip icons at the end of this form. You may attach up to (5) files per icon up to 25MB:

The project must be reviewed by the Commission at one of their monthly meetings as the windows appear to be distinctive character-defining features of this resource and, in staff's opinion, are not demonstrably beyond reasonable repair.

Currently, this application is incomplete as it is missing the following:

- Current photos of all 4 sides of the house from the exterior
- Exterior photos of all of the windows proposed for replacement. Each photo/window depicted in each photo must be numbered to correspond with the numbers outlined in this application's (HDC2026-00106) submitted window schedule and window condition/assessment report.
- Elevation and horizontal and vertical sections for the existing wood windows (typical). Window sections must show the profiles and typical dimensions of muntins, meeting rails, sash, frames, moldings, and other features. Also, indicate the window's relationship to the existing wall plane.

This above-listed information is due in complete by 3/18/2026 by 12:00PM if you would like your application to be docketed to the upcoming April 8, 2026 meeting agenda. If any of the above-listed outstanding items are received after 3/18/2026, 12:00PM, the project will be added to the Commission's May 2026 meeting agenda for their review.

Finally, please see the attached Historic District Commission Guidelines on historic window repair. Consider submitting additional documentation of deterioration and/or a price quote for repair from an experienced window restorer if you wish to further define the condition of the windows proposed for replacement.

Thank you,



PSR: Jennifer

260317JR

APPLICANT RESPONSE

Response Date: 03/03/2026



I have provided the following information to address the response comments

1. Drawing A500 (P) Exterior Elevation Photos is photographs of the (4) existing elevations with the existing wood windows which are deteriorated identified on the elevation.
2. Drawings A762 Ex Window Details has horizontal and vertical sectional details showing all the components of the existing windows. Additionally the page includes the proposed window details for comparison
3. The pdf 264 Existing Windows - Individual Photos has photos of each window and are identified to the numbering system found on all the elevations.

Guidelines for Historic Wood Windows

Detroit Historic District Commission

Repair is the First Option for Historic Wood Windows

The Detroit Historic District Commission (HDC) follows the Secretary of Interior Standards for Rehabilitation for historic properties <https://www.nps.gov/subjects/taxincentives/secretarys-standards-rehabilitation.htm>.

For historic windows, Standard 6 is most directly applicable:

Standard 6. Deteriorated historic features will be repaired rather than replaced. Where the severity of deterioration requires replacement of a distinctive feature, the new feature will match the old in design, color, texture and, where possible, materials. Replacement of missing features will be substantiated by documentary and physical evidence.

The central message of the Standards is that historic windows will be repaired rather than replaced. Only when a window has severely deteriorated, and it cannot be repaired, may it be replaced. Generally, even badly deteriorated windows can be repaired by crafts persons who know about historic windows. The standard for replacement windows is strict.

"I've assessed the condition of more than a thousand [sashes], and never seen a sash that could not be repaired." John Leeke (well-known window contractor), Historic Home Works

The Standards for Rehabilitation are from the Secretary of the Interior, National Park Service.¹ The HDC is required to follow these Standards by the Detroit City Ordinance for historic districts.²

Standard 2 also applies directly, because historic windows are a defining characteristic of historic buildings.

Standard 2. The historic character of a property will be retained and preserved. The removal of distinctive materials or alteration of features, spaces and spatial relationships that characterize a property will be avoided.

Other Standards also relate to windows less directly.

¹ "The Secretary of the Interior's Standards for Rehabilitation." National Parks Service, U.S. Department of the Interior, <https://www.nps.gov/subjects/taxincentives/secretarys-standards-rehabilitation.htm>

² "2019 Detroit City Code, Sec. 21-2-73. - Issuance of Certificate of Appropriateness." https://library.municode.com/mi/detroit/codes/code_of_ordinances?nodeId=CICOCH21--43_CH21HI_ARTIIHIDILA_DIV4PEWOWIDI_S21-2-73ISCEAP

What Constitutes Repair of an Historic Wood Windows.

The principal objective of the Standards for Rehabilitation is to preserve historic properties and their features for the future. For historic windows to be preserved, they must be kept in good repair. Most of all, preservation requires regular maintenance. When a portion of a window has deteriorated, due to lack of maintenance or damage, it must be repaired sufficiently to assure its survival.

A historic window that is preserved for the future will have these characteristics:

1. No broken or cracked panes of glass.
2. Glazing putty on the exterior is intact and painted.
3. Paint is intact, with no flaking paint.
4. Wood windowsills are intact and painted.
5. All components of the window sash are intact and painted.
6. Any missing sash (upper, lower, or both) is replaced to match the originals closely.
7. The window jambs, brickmould, head, and casing are intact and painted.
8. Caulking **in** between brick molds and casings to prevent moisture incursion.
9. Any window that must be opened is operable: lower sash can move up and down; casement windows can swing open.

Operability is not a required condition for a fully repaired window. For example, upper sash rarely are opened and do not need to be operable. Other windows that are not opened do not need to be operable.

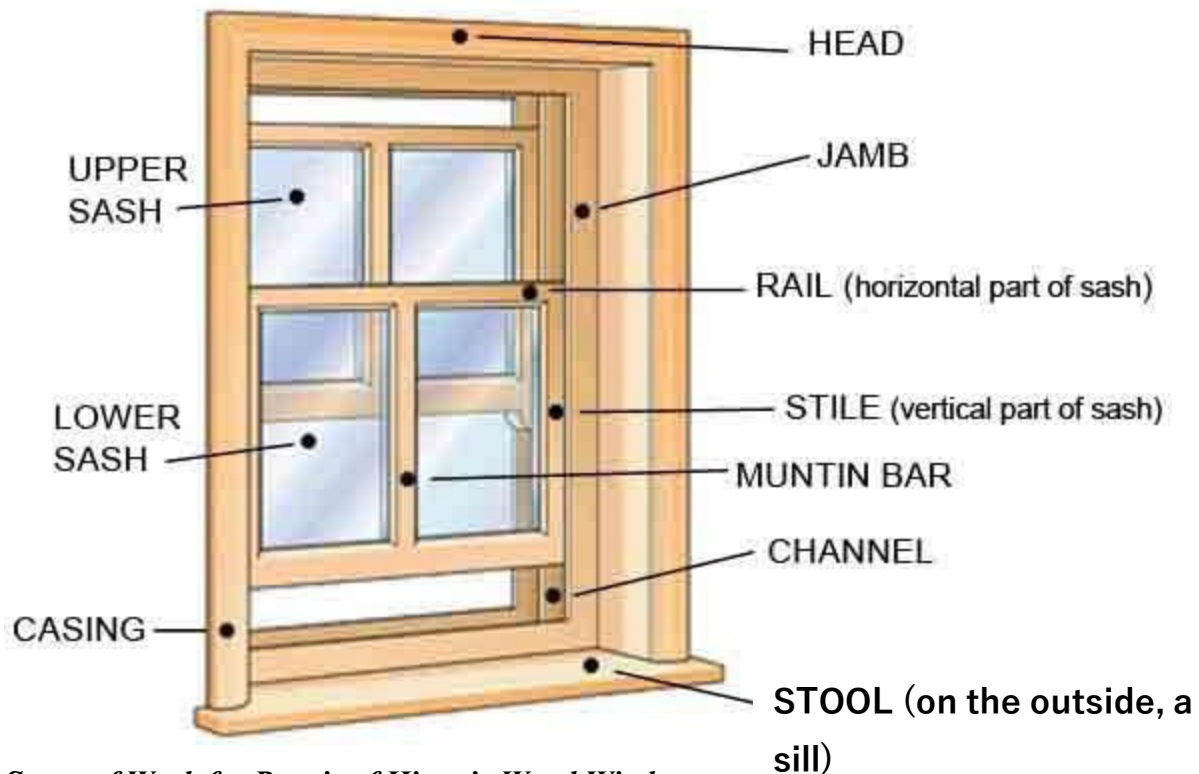

Scope of Work for Repair of Historic Wood Windows

A historic wood window that lacks any of these characteristics will need to be repaired to preserve it into the future. Often the repairs are just elements of deferred maintenance.

The Scope of Work for repair is for individual windows. The Scope of Work will include just the minimum repairs necessary for the window to have all of the characteristics of a historic window preserved into the future.

On most buildings, many windows are likely to be in good repair and require little or no repair. For example, upper sash often need little repair. Some windows may need extensive repair work; lower sash and windowsills often need repair.

These repairs may be necessary to rehabilitate an individual window:

1. Broken or cracked panes of glass must be replaced.
2. Glazing putty at panes of glass on the exterior must be intact to protect the window. Intact glazing can be left in place; missing or deteriorated glazing must be replaced.
3. If there is flaking paint or bare wood, it must be scraped or sanded to prepare for primer and final coats of paint to protect the window.
4. Wood windowsills must be stabilized or repaired and sealed with primer and final coats of paint; if severely deteriorated, wood sills can be replaced in kind. Sills must slope away from the window to drain water.
5. If a sash has a deteriorated component (rail, stile, or muntin), that component must be stabilized or repaired sufficiently to preserve the window. Individual elements can be replaced in kind.
6. If a sash is missing or unrepairable, a new sash can replace the missing sash; the new sash must match the original sash closely.
7. If the window jambs, brickmould, head, and casing are deteriorated or damaged, they must be repaired or replaced in kind.

Prioritize Repairs

Some window repairs can have higher priorities than others. Spreading out the repair over time also spreads out the expense, which may be more manageable, if funds or financing are not available to do all repairs at one time.

1. Window Usage

In most buildings, occupants open some windows and not others. Windows that are the most important to be opened can have higher priority and be repaired first. For windows that are never opened, repairs can be deferred. Upper sash rarely are opened - only lower sash may need repair. Even if an unused window needs substantial repair, if it is covered by a storm window, that protection can allow deferral of the repair, perhaps for many years; in this way, a window is “mothballed” for future repair.

2. Window Conditions

For most buildings, the conditions of windows will vary. Some will be in good repair. Often upper sashes in double-hung windows get little wear and are in good condition. Some windows may need extensive repairs, including replacement of some components. And some will need small repairs. Windows that need the most repair can have higher priority to be repaired.

Beyond Repair

Full Restoration

Historic windows can be restored close to their original condition. While such a restoration to a “like new” condition is an ultimate goal, this goes beyond the repair necessary to preserve windows into the future, until a fuller restoration is possible.

A brief scope of work for a more extensive restoration is below. A full restoration may require that the window be disassembled.

1. Necessary repairs are, of course, the first step in a full restoration.
2. Paint or finish build-up (both exterior and interior) can be removed and replaced with fresh finishes. Interior finishes often are other than paint: they may not have as much build-up and can be refreshed rather than removed. As old paint may be lead-based, caution is required and safety steps must be implemented.
3. Glass can be fully reglazed.
 - a. Most simply, all glazing putty can be removed and replaced.
 - b. Further, glass panes can be removed from their beds (glazing rabbets), the beds cleaned, a thin layer of glazing compound applied to the beds, and the glass reset and reglazed.
4. Window hardware can be thoroughly cleaned and lubricated, or perhaps replaced to match the original.
5. On double-hung windows, sash ropes can be replaced, and pulleys can be lubricated or replaced.
6. New weather stripping can be added as needed.

Weatherization

A historic wood window that is in good repair also can be weatherized to reduce heat loss. Weatherization blocks cold air infiltration and prevents the escape of warm air. Energy also is lost through heat conduction through glass, which weatherization can reduce. In addition, weatherization measures also can reduce moisture infiltration that damages window structures.

The most effective weatherization is a tight-fitting storm window.

1. If exterior storms exist, they can be updated with new stripping and brush seals or rubber seals, and latches lubricated or replaced. Replace any broken glass.
2. Replace any missing glass and screen panels.
3. If there are no storms, there are both exterior and interior storm window options.

4. For exterior storms, caulking around the edges will reduce air infiltration and tighten the air space to reduce convection. However, do not caulk the bottom edge of storms, as this leaves a space for moisture to escape.
5. Exterior storms also protect windows from deterioration from weathering.

Storm windows and tightly weatherized sash create a large dead air pocket, which is an insulator. This is the same principle of insulation as a modern double-paned window sash, but with a much larger dead air space.

Several additional weatherization steps include:

1. Caulk around the exterior of windows where the jambs, brickmould and casing join the house. Heads and sills should not be caulked: open spaces allow moisture to escape.
2. On the interior, any space between interior casing and plaster walls can be sealed with spackling.
3. Weatherstripping on the interior between sash and jamb, using inexpensive weather stripping.
4. Sash locks in good repair (or replaced) keep the upper and lower sash tightly sealed.

Window Replacement

When a historic window is missing, it can be replaced. Also, when a window is so deteriorated or damaged that repair is either technically not feasible or economically not reasonable, it can be replaced.

For economic reasonableness, the cost of repair that is relevant is the cost of the scope of repair, as delineated above. While a full restoration will have higher cost, that is not the relevant cost to consider with respect to window replacement.

What is a reasonable cost of repairing a window is contingent on the importance of the window. In a building, a window or set of windows may be so important to the architectural design of the building that they need to be repaired even at a fairly high cost rather than replaced. For example, a large leaded-glass window in a prominent location may be crucial to the character of a building.

Replacement windows must conform to conditions specified in Standard #6: *the new feature will match the old in design, color, texture and, where possible, materials.*

1. New windows must match the original windows in operation: most often windows are fixed panes, double-hung, or casement. There are other types.
2. The pattern of lites (panes) in the window must match that in the original window. For example, if an upper sash has 6 lites and the lower sash has only one, then the new windows must have the same configuration. There are many different configurations of lites observed in historic windows. Often these are highly distinctive configurations that are integral to the architecture of the building.
3. The dimensions of the window components (the rails, stiles, and muntins) should match or be very close to the dimensions of the components of the original window.

4. Multipaned windows must be replaced with either true divided lite windows or windows with simulated divided lites. Faux muntins between the glass panes of double-glazed window glass do not provide the same shadow lines and depth as historic windows and are inappropriate.
5. The color of the new windows must be within the color palette appropriate for the architectural style of the building.
6. The material of new windows should be the same as the original windows or be reasonably close in appearance.

ADOPTED BY THE DETROIT HISTORIC DISTRICT COMMISSION MARCH 13, 2024

MARVIN Ultimate Wood Double Hung

Section Details: Operating
Scale: 3" = 1'-0"

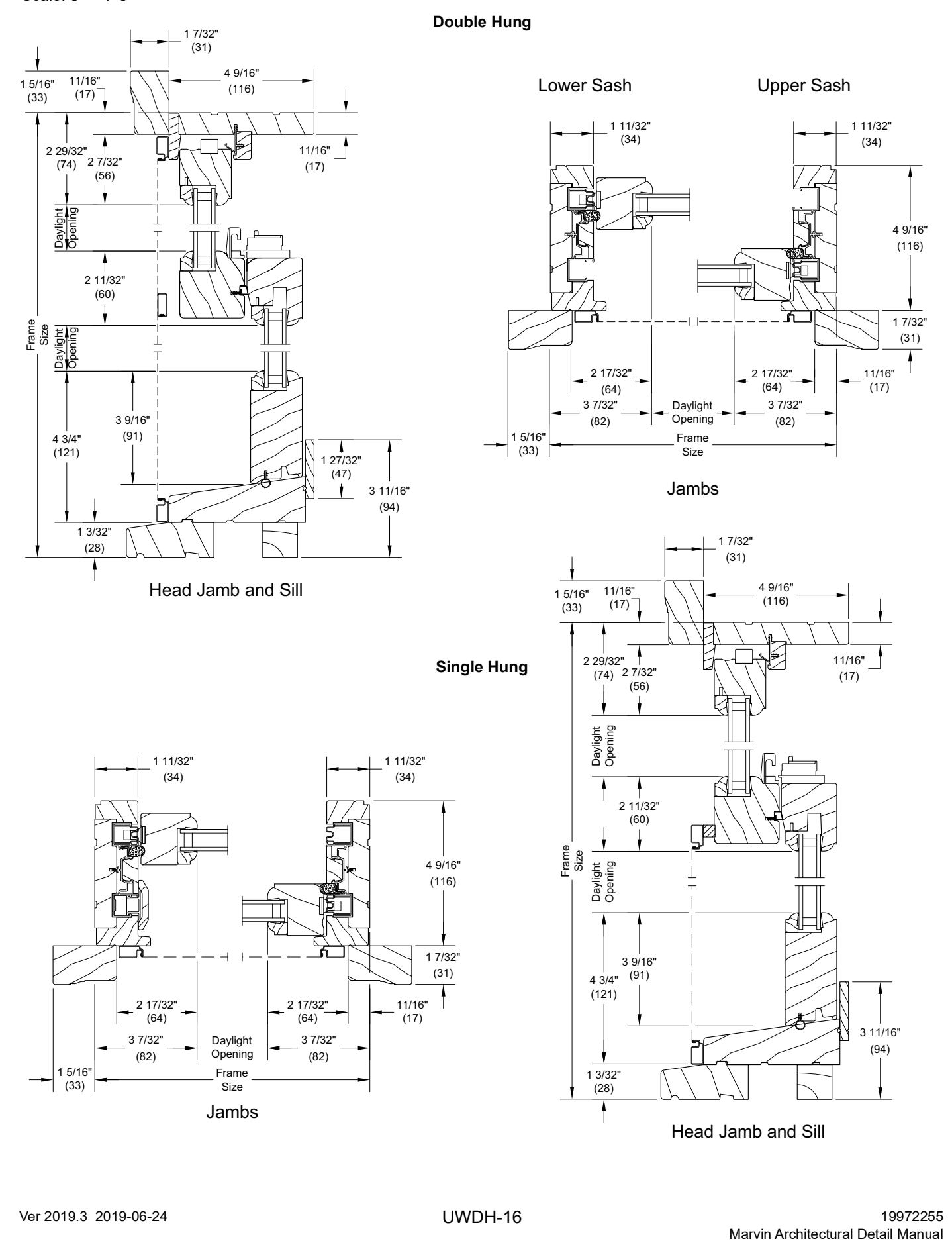

Ver 2019.3 2019-06-24 UWDH-16 19972255 Marvin Architectural Detail Manual

6 PROPOSED MARVIN ULTIMATE SERIES WINDOW DETAILS
SCALE: 3" = 1'-0"

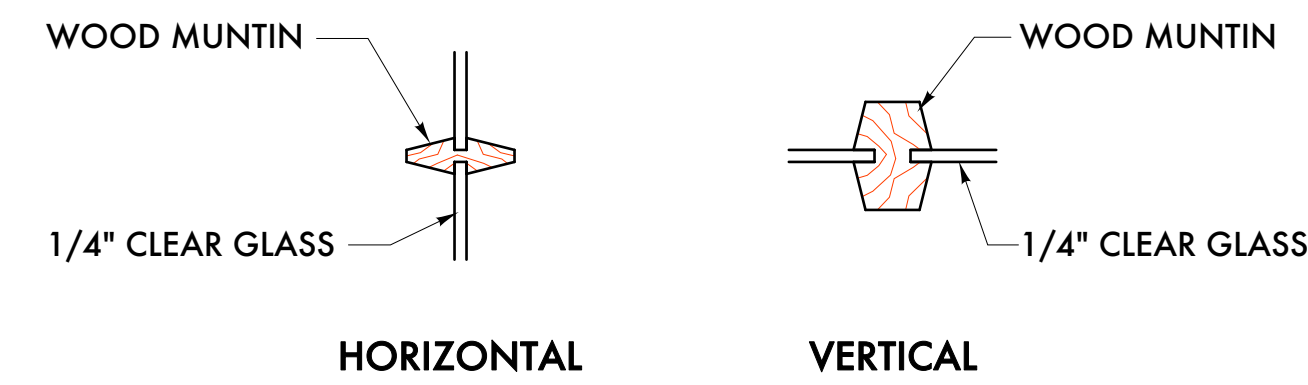

5 EXISTING WINDOW MUNTIN DETAILS
SCALE: 3" = 1'-0"

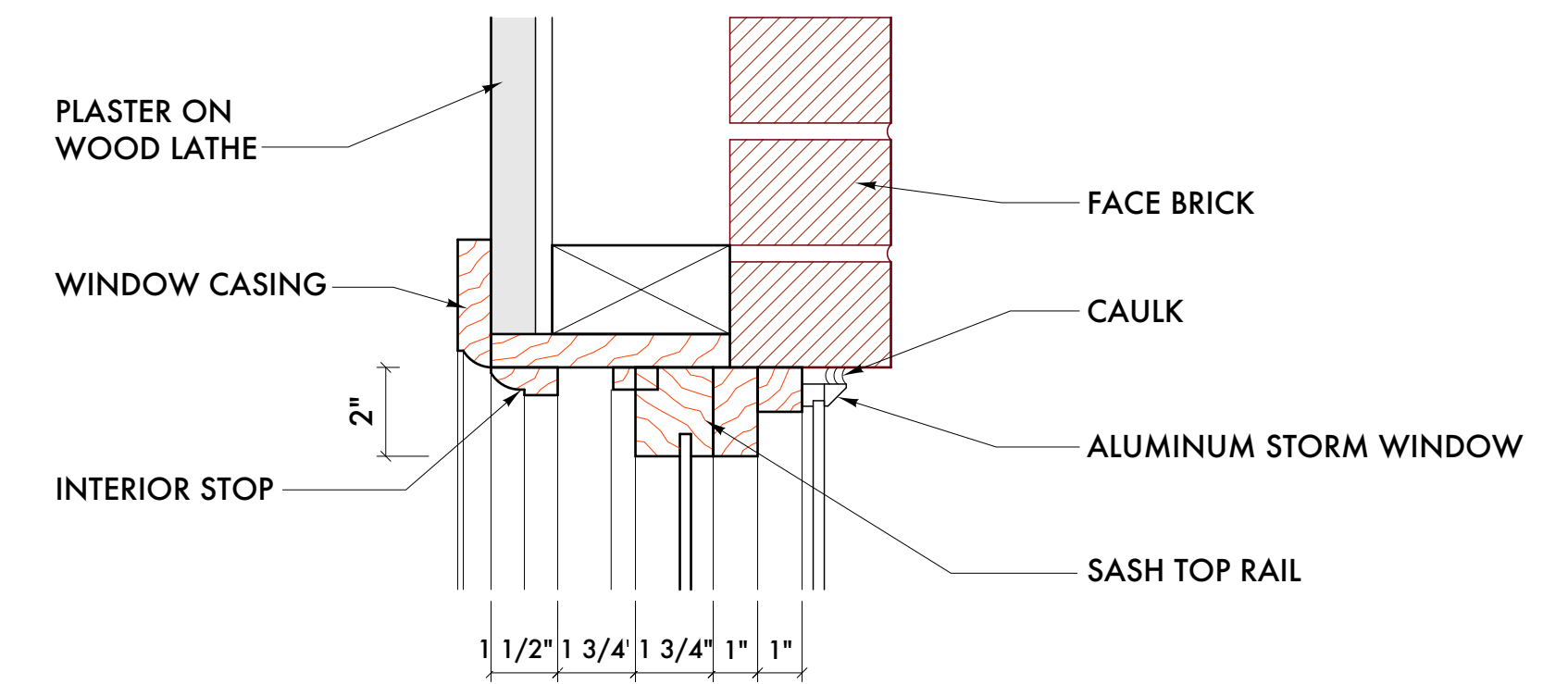

4 EXISTING WINDOW HEAD DETAIL
SCALE: 3" = 1'-0"

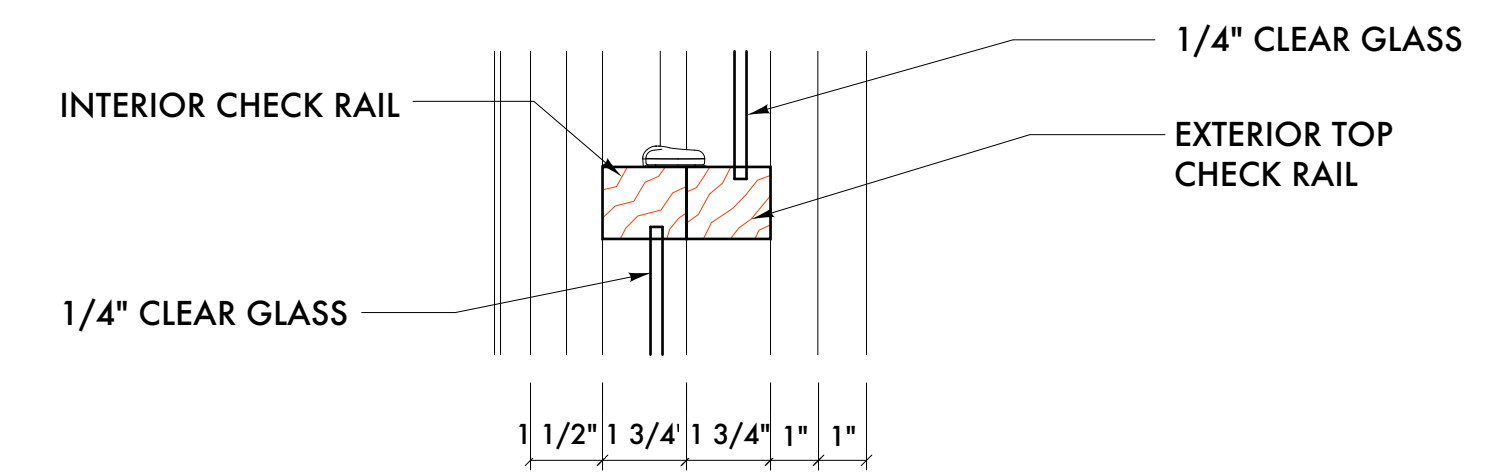

3 EXISTING WINDOW CHECK RAIL DETAIL
SCALE: 3" = 1'-0"

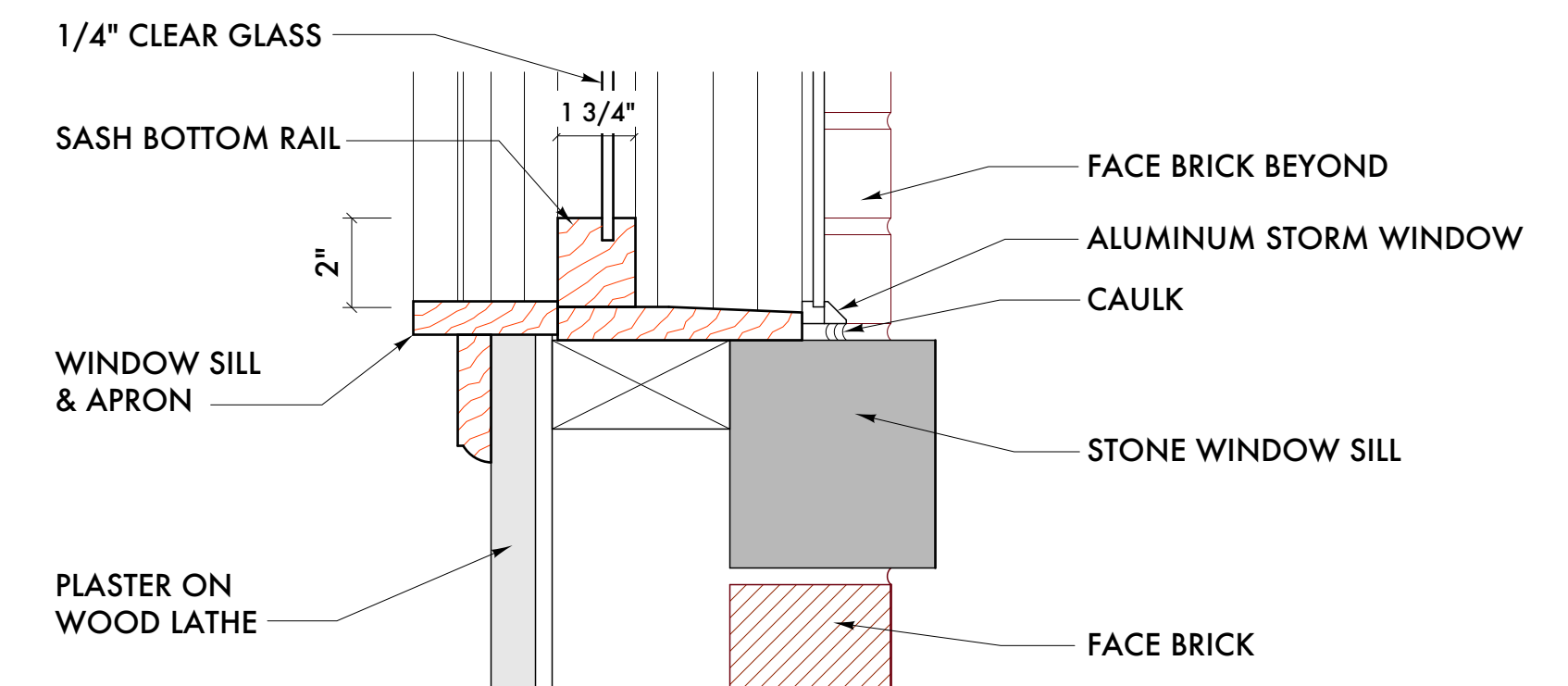

2 EXISTING WINDOW SILL DETAIL
SCALE: 3" = 1'-0"

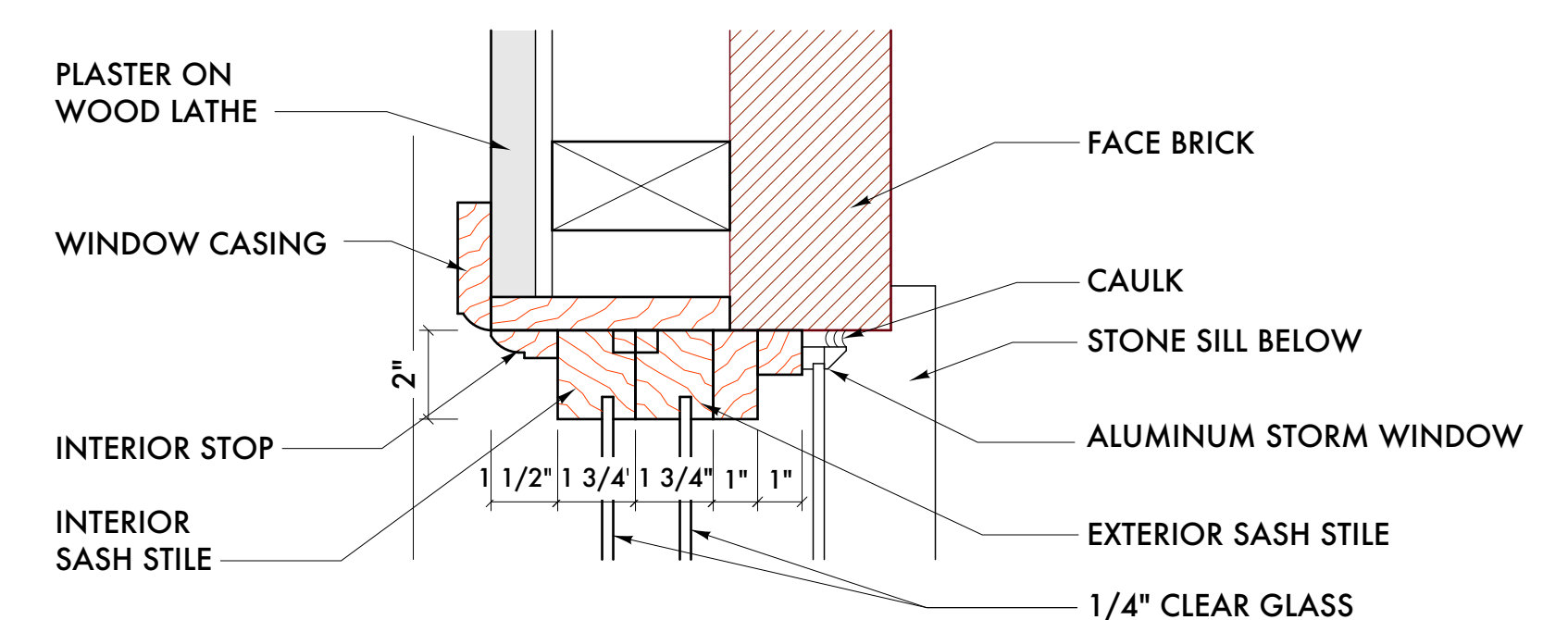

1 EXISTING WINDOW JAMB DETAIL
SCALE: 3" = 1'-0"



03/18/26 HDC Revisions
Date: Issued For:

Watson Residence
Historic Home
264 East Watson
Detroit, Michigan 48201

studioONE : DETROIT
architectural | urban | interior | DESIGN
350 Madison Avenue
4th Floor
Detroit, Michigan 48226
studioonedetroit.com
313.549.2790 | jpb@watsonhouse.com

Project Number: 2024 - 02

Sheet Title:
EXISTING & NEW WINDOW DETAILS

Sheet Number:
A7.62
© 2026 studioONE, llc

INDICATES A WOOD WINDOW W/ SUCH EXTENSIVE DAMAGE IT CAN NOT BE REPAIRED

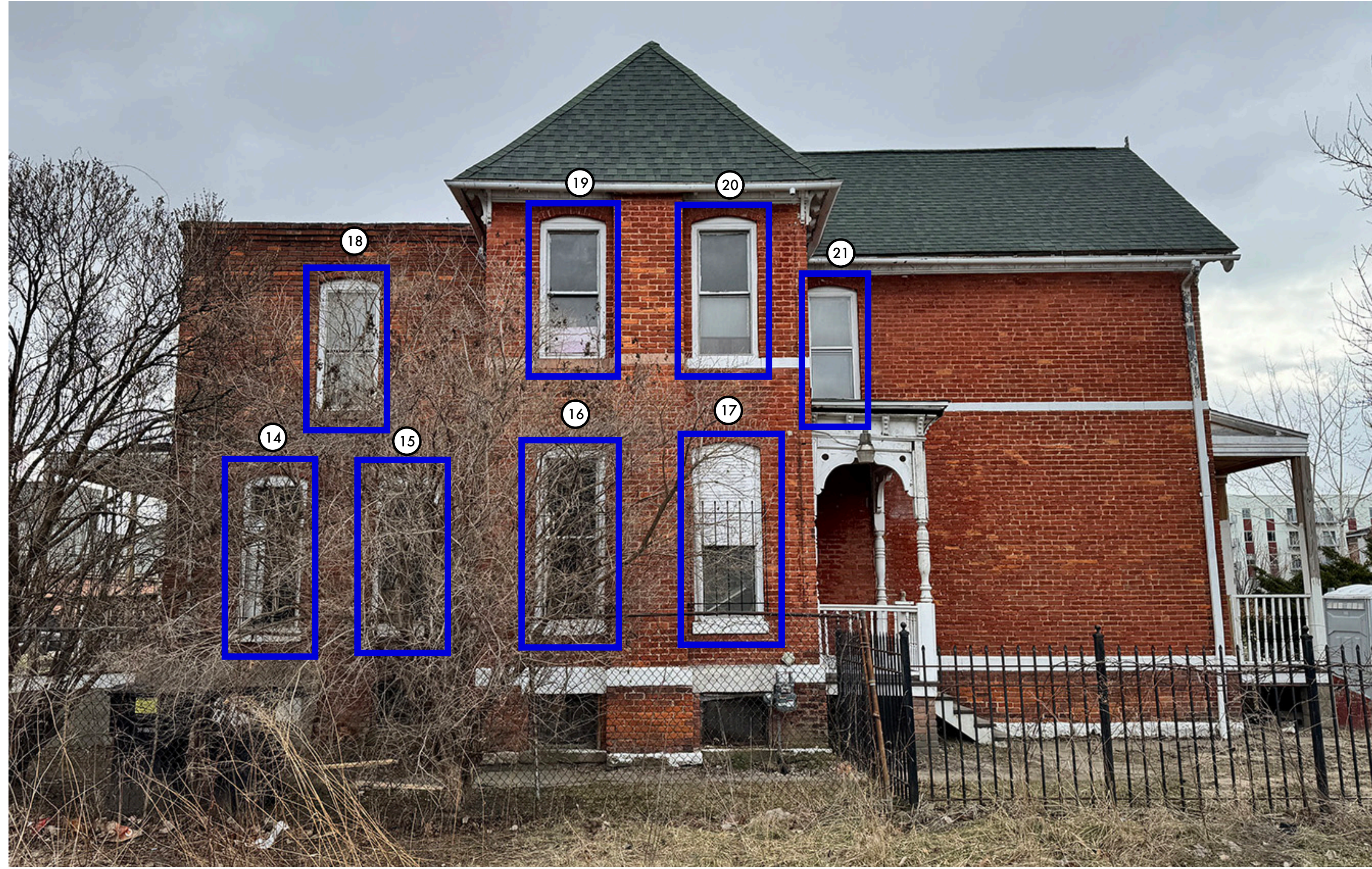

B EAST ELEVATION
NOT TO SCALE



A NORTH (WATSON STREET) ELEVATION
NOT TO SCALE



D WEST ELEVATION
NOT TO SCALE



C SOUTH (ALLEY) ELEVATION
NOT TO SCALE



03/18/26 HDC Revisions
Date: Issued For:

Watson Residence
Historic Home
264 East Watson
Detroit, Michigan 48201

studiozONE : DETROIT
architectural | urban | interior DESIGN

350 Madison Avenue
4th Floor
Detroit, Michigan 48226
studiozonedetroit.com
313.549.2790 (t)
jbb@watsonresidence.com

Project Number: 2024 - 07

Sheet Title:
EXTERIOR BUILDING PHOTOGRAPH ELEVATIONS

Sheet Number:
A5.00 (P)

© 2026 studiozONE, llc



Windows 7, 8 & 9



Window 14



Window 15



Window 16



Window 17



Window 18



Window 19



Window 20



Window 21



Window 23



Window 24



Window 30



Window 31