



# HISTORIC DISTRICT COMMISSION APPLICATION FOR WORK APPROVAL

City of Detroit - Planning & Development Department  
2 Woodward Avenue, Suite 808  
Detroit, Michigan 48226

<b>APPLICATION ID</b>
HDC2025-00012

## PROPERTY INFORMATION

<b>ADDRESS(ES):</b> 644 Selden
<b>HISTORIC DISTRICT:</b> Willis-Selden

**SCOPE OF WORK: (Check ALL that apply)**

- |  |   |  |  |   |   |
|--|---|--|--|---|---|
| <input checked="" type="checkbox"/> Windows/ Doors | <input checked="" type="checkbox"/> Walls/ Siding | <input checked="" type="checkbox"/> Painting | <input type="checkbox"/> Roof/Gutters/ Chimney | <input type="checkbox"/> Porch/Deck/Balcony   | <input checked="" type="checkbox"/> Other |
| <input type="checkbox"/> Demolition                | <input type="checkbox"/> Signage                  | <input type="checkbox"/> New Building        | <input type="checkbox"/> Addition              | <input type="checkbox"/> Site Improvements (landscape, trees, fences, patios, etc.) |   |

<b>BRIEF PROJECT DESCRIPTION:</b>
The project involves renovating the ground-floor restaurant space with interior and exterior improvements. Exterior improvements are included in the submission.
The project is being submitted on behalf of the tenant, who is different from the property owner.
Tenant/Business Occupant: Ama Molto Hospitality II Anthony Lombardo

## APPLICANT IDENTIFICATION

<b>TYPE OF APPLICANT:</b> Architect/Engineer/Consultant			
<b>NAME:</b> Ryan Smith	<b>COMPANY NAME:</b> Patrick Thompson Design		
<b>ADDRESS:</b> 2111 Woodward Ave.	<b>CITY:</b> Detroit	<b>STATE:</b> MI	<b>ZIP:</b> 48201
<b>PHONE:</b> +1 (313) 800-4005	<b>EMAIL:</b> rsmith@patrickthompsondesign.com		

## I AGREE TO AND AFFIRM THE FOLLOWING:

- I understand that the failure to upload all required documentation may result in extended review times for my project and/or a denied application.
- I understand that the review of this application by the Historic District Commission does not waive my responsibility to comply with any other applicable ordinances including obtaining appropriate permits (building, sign, etc.) or other department approvals prior to beginning the work.
- I hereby certify that the information on this application is true and correct. I certify that the proposed work is authorized by the owner of record and I have been authorized to make this application as the property owner(s) authorized agent.

<p>Signed by:  0145CA14D119470...</p> <hr style="border: 0.5px solid black;"/> <p><b>SIGNATURE</b></p>	<p>01/15/2025</p> <hr style="border: 0.5px solid black;"/> <p><b>DATE</b></p>
--	---

**NOTE: Based on the scope of work, additional documentation may be required. See [www.detroitmi.gov/hdc](http://www.detroitmi.gov/hdc) for scope-specific requirements.**

## PROJECT DETAILS – TELL US ABOUT YOUR PROJECT

**Instructions: Add project details using the text box in each section. If your details exceed the space provided, attach the details via the attachment icon for that section.**

**ePLANS PERMIT NUMBER:**

(only applicable if you've already applied for permits through ePLANS)

n/a

### GENERAL

**1. DESCRIPTION OF EXISTING CONDITION**

*Please tell us about the current appearance and conditions of the areas you want to change. You may use a few sentences or attach a separate prepared document on the right. (For example, "existing roof on my garage is covered in gray asphalt shingles in poor condition.")*

**2. PHOTOGRAPHS**

*Help us understand your project. Please attach photographs of all areas where work is proposed.*



**3. DESCRIPTION OF PROJECT**

*In this box, tell us about what you want to do at the areas described above in box #1. (For example, "Install new asphalt shingle roofing at garage.")*



**4. DETAILED SCOPE OF WORK**

*In this box, please describe all steps necessary to complete the work described in box #3. (For example, "remove existing shingles, replace wood deck as necessary, replace wood eaves, install roof vents, replace rotted fascia boards, paint, clean worksite.")*

**5. BROCHURES/CUT SHEETS**

*Please provide information on the products or materials you are proposing to install. For example, a brochure on the brand and color of the shingles proposed.*

## ADDITIONAL DETAILS

<p><b>6. WINDOWS/DOORS</b> <i>Detailed photographs of window(s) and/or door(s) proposed for replacement showing the condition of the interior and exterior of the window(s) and/or door(s)</i></p>	
<p><b>9. OTHER</b> <i>Please provide any additional details. HDC Staff may ask you to submit additional information at a later time depending on your project.</i></p>	

# **Ama Molto Hospitality II** **HDC Proposal** **01/15/2024**

patrick  
thompson  
design



## Index

<b>03</b>	<b>Existing Location and Context Plan</b>
<b>04</b>	<b>Description of Existing Conditions</b>
<b>05-06</b>	<b>Existing Condition Photos</b>
<b>07</b>	<b>Description of Project</b>
<b>08</b>	<b>Proposed Floor /Site Plan</b>
<b>09</b>	<b>Detailed Scope of Work</b>
<b>10-14</b>	<b>Proposed Exterior Elevations / Views</b>
<b>15-16</b>	<b>Proposed Finishes</b>
<b>17-21</b>	<b>Brochures / Cut Sheets</b>



# Existing Location and Context Plan

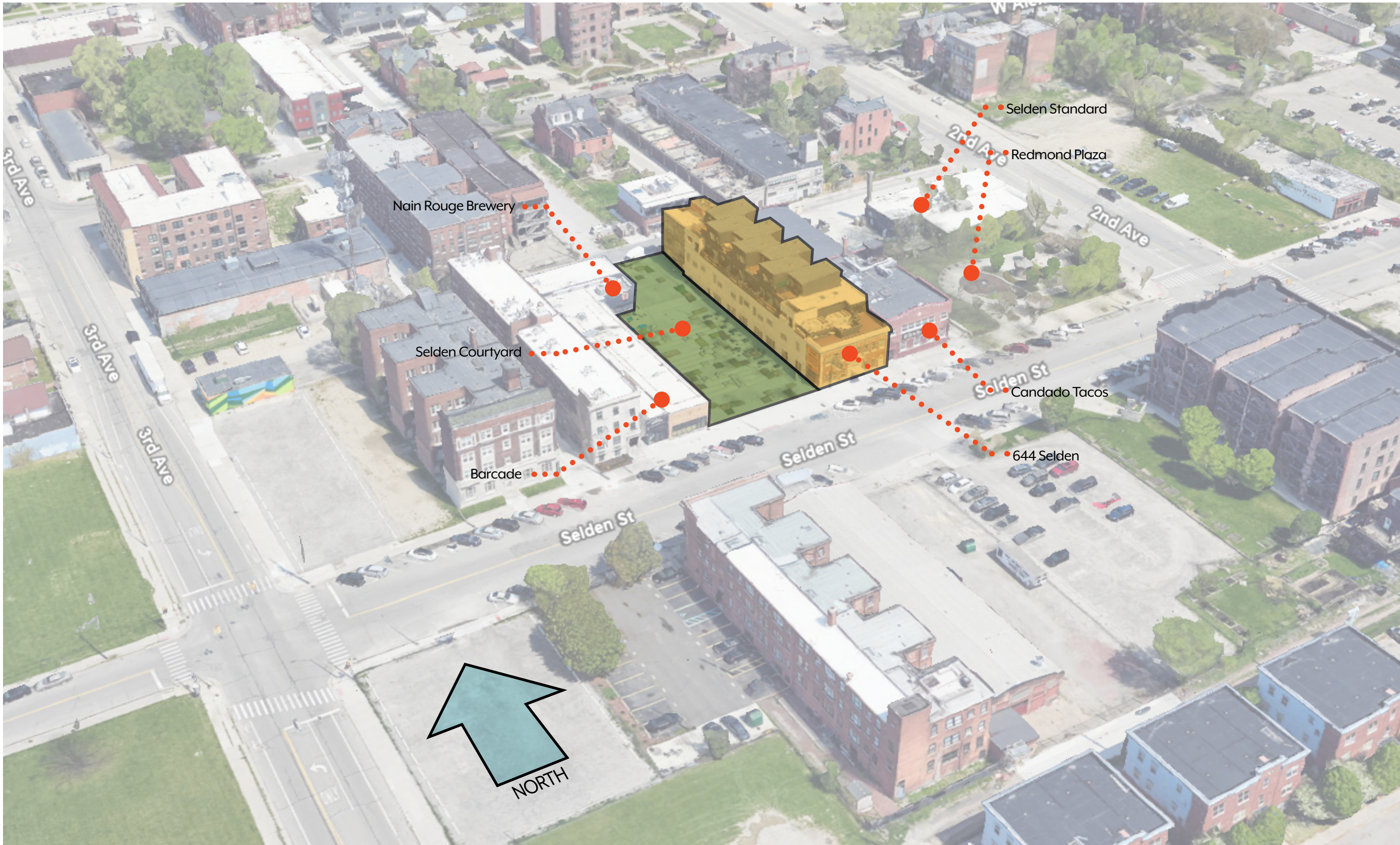



## Description of Existing Conditions

The building located at 644 Selden is a mixed-use property consisting of a first-floor vacant restaurant, a second-floor office space, and modern third and fourth floor residential units.

**South Façade (primary façade)** - The building materials along the south façade along Selden consist of unfinished, natural brick and limestone trim (entry entablature and pilasters, quoining, sills, window keystones, water table, and limestone base); the limestone entry entablature and pilasters are painted black. There are aluminum double-hung replacement windows in all the window openings painted white. There are two flush metal entry doors with painted plate steel trim and a painted modern canopy at the main entry. There is a blade sign mounted to the left side of the second floor.

**West Façade (secondary façade)** – this façade abuts a public courtyard (Selden Courtyard) along its entirety. The finishes consist of unfinished, natural brick with a repainted mural at the south end; painted brick and concrete on the first two floors of the center section; and painted metal siding with clear glazing on the second and third floors and surrounding the stair tower at the north end. Windows and doors located within the painted brick areas on the first and second floor are recent improvements with superfluous glazing with applied brick pattern frit.

**East Façade** – the east façade abuts the adjacent property at 634 Selden (Condado Tacos)

**North Façade** – this façade abuts an active alley and the building materials consist of unfinished, natural brick, concrete, and a recently constructed clear glazing and metal panel stair tower.



## Existing Conditions



Looking Northeast from Selden Street



Looking North from Selden Street



Looking Northwest from Selden Street



Looking North from Selden Street (existing painted limestone main entry; existing double hung aluminum frame windows w/ white frame)



## Existing Conditions



Looking Northeast from Selden (existing West facing mural and South facing blade sign)



Looking North from courtyard (subject building on right)



Looking South from courtyard (subject building on left; existing glazing graphic detail; typical on 1st and 2nd floor West facade)



Looking East from courtyard (existing painted brick and glazing graphic detail; typical on 1st and 2nd floor West facade)



## Description of Project

The project consists of renovating the ground-floor restaurant space with both interior and exterior improvements.

Along the south façade, the existing entry canopy would be removed, door/sidelights would be replaced with a new system, the existing painted limestone entablature and pilasters would be stripped to the original stone, and sconces would be installed on the limestone pilasters to reflect the proposed theme of the restaurant. New awnings would flank the existing entry and would wrap around to the west façade to guide people to the relocated restaurant entry. The existing double-hung window frames on the first and second floors would be painted a neutral tone. Lastly, the existing non-historic blade sign on the south façade would be removed and a new blade sign would be installed on the SW corner at the second floor to reflect the restaurant branding.

Along the west façade, four retractable awnings would be installed above the existing structural bays to cover outdoor dining, a new main entry would be created with a new door and sidelight replacement, sconce lighting would be installed on the existing concrete columns adjacent to the outdoor dining areas, the first floor painted brick and concrete would be repainted to reflect the proposed theme of the restaurant, the existing aluminum doors and frames would be painted a neutral tone, and the existing mural would be repainted to reflect the restaurant theme.

# Proposed Floor Plan

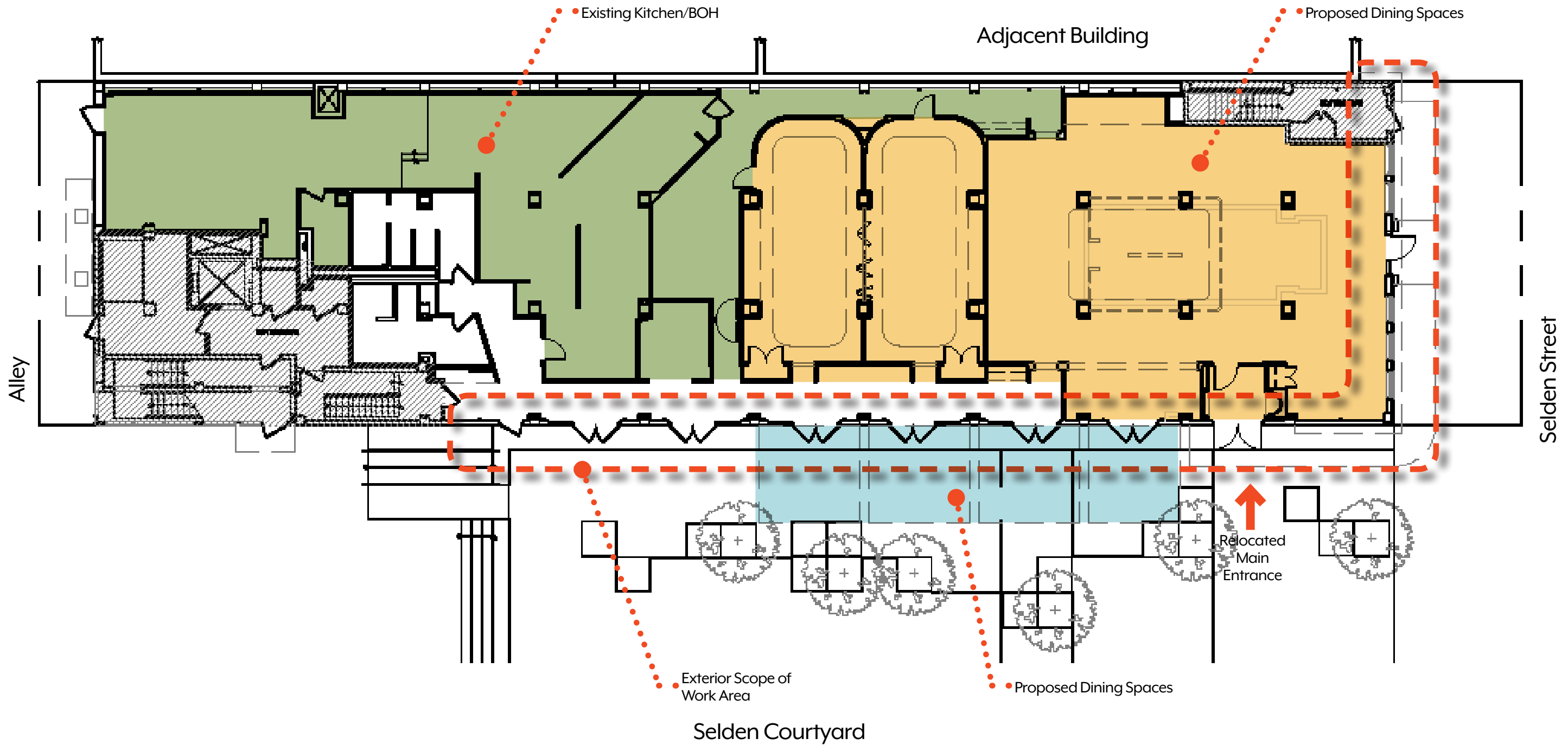

## Detailed Scope of Work

### South Façade (primary façade) -

- Remove entry canopy along the south facade (Selden Street)
- Remove and replace front entry door and sidelight along south façade with a theme appropriate design
- Add two fixed separate awnings along south façade with one continuing around and onto the west façade above the proposed entry
- Remove 'Smith Welding' blade sign from south façade and replace with a new brand appropriate design to the SW corner of the building
- Strip paint from limestone entry entablature and pilasters down to original stone
- Paint first and second floor double-hung window frames with a neutral tone

### West Façade (secondary façade) –

- Remove superfluous glazing with applied brick pattern frit from all first-floor doors/windows along west façade
- Paint existing doors and frames a neutral tone
- Repaint first floor brick and exposed concrete columns along west façade with a theme appropriate color
- Remove pair of doors from bay along the west façade and replace with a theme appropriate design – to be used as restaurant main entrance
- Refinish new main entrance bay on west façade with a theme appropriate finishes
- Add four retractable awnings along west façade
- Remove the 'Quality food and beer' sign from the first floor
- Repaint second floor mural on west façade with a theme appropriate design
- Remove fire pit from courtyard for expanded outdoor seating area



# Proposed Views | ISO looking Northeast

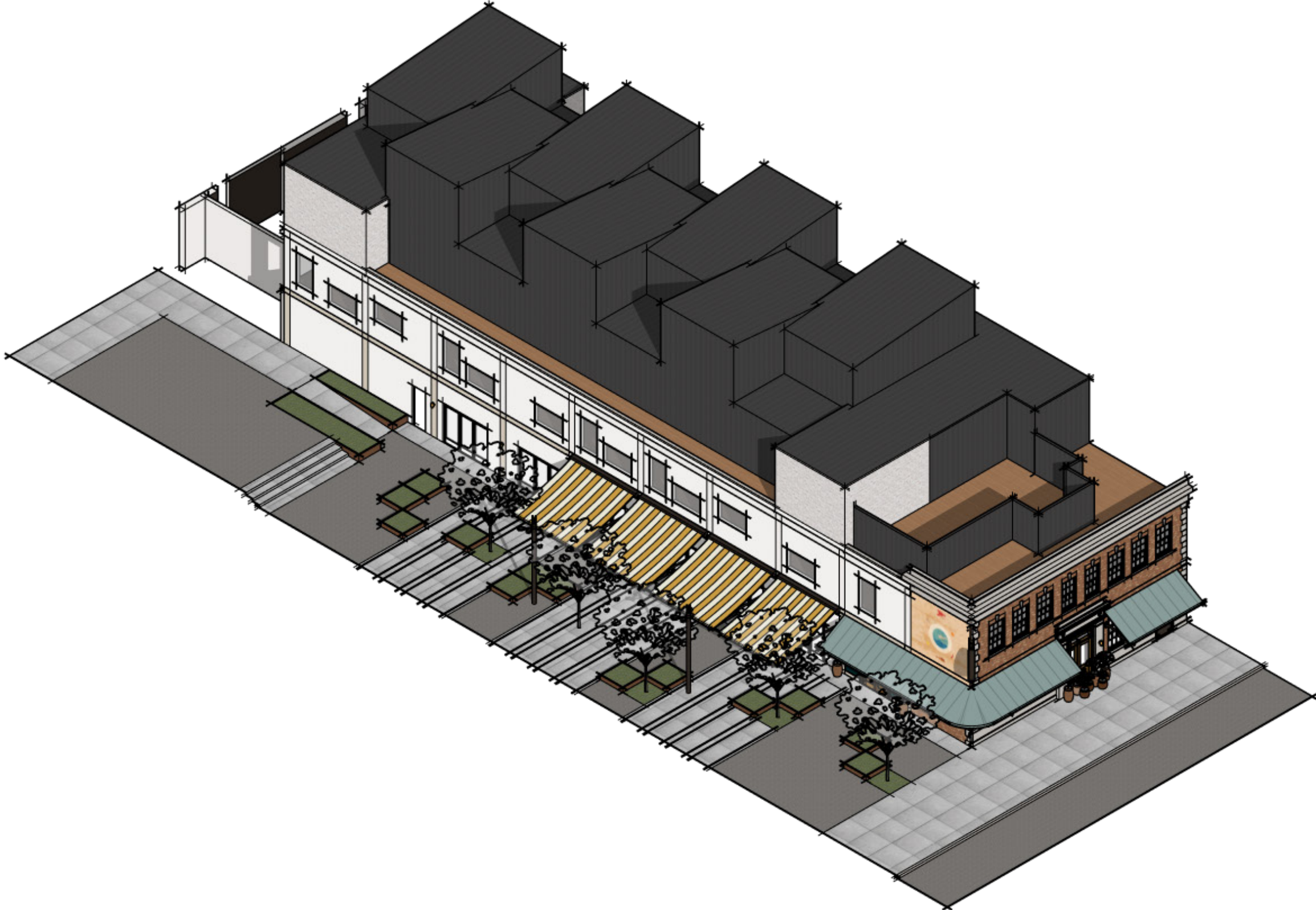

# Proposed Views | South Elevation

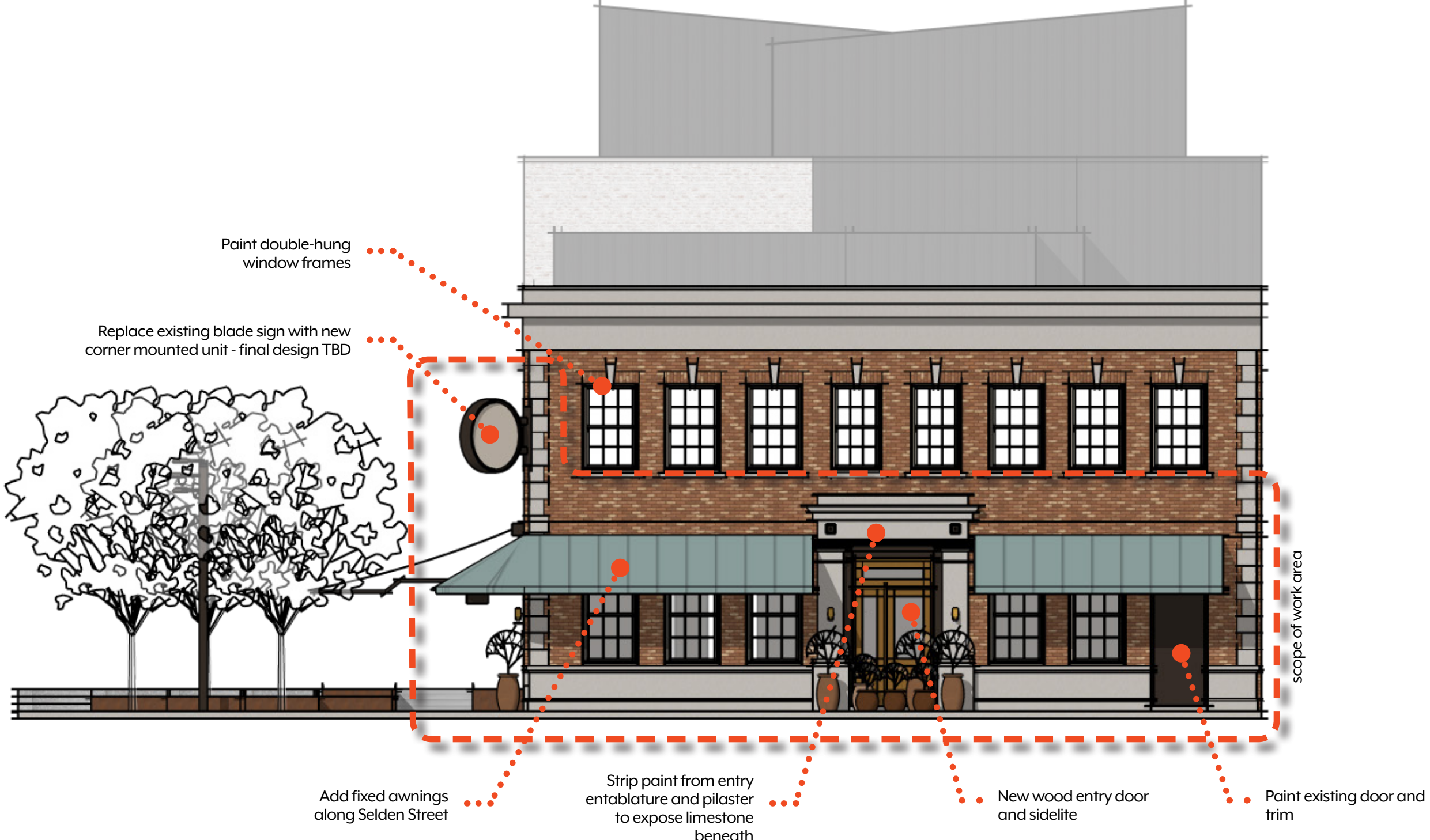



# Proposed Views | West Elevation

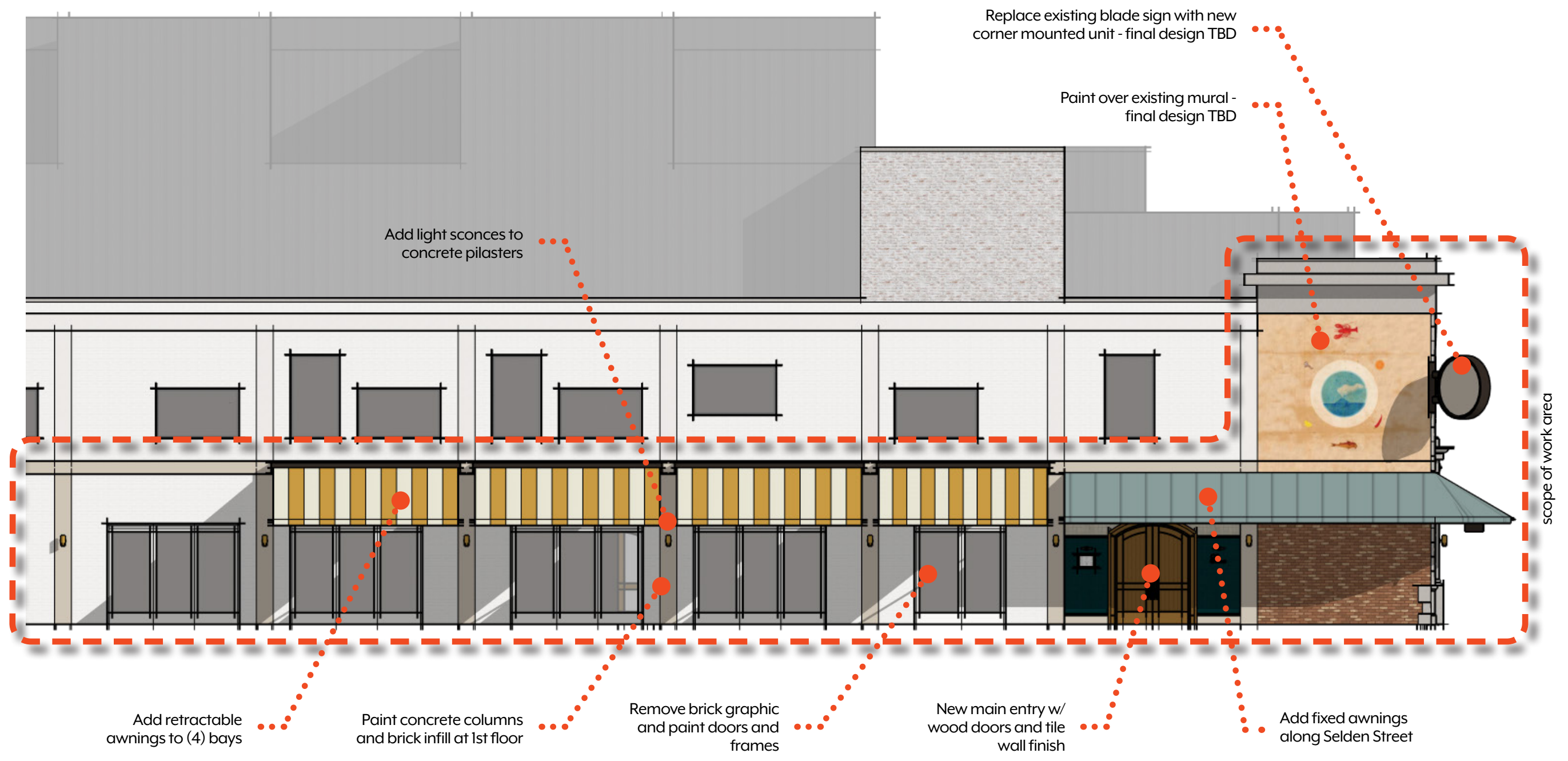



# Proposed Views | Perspective looking Northwest

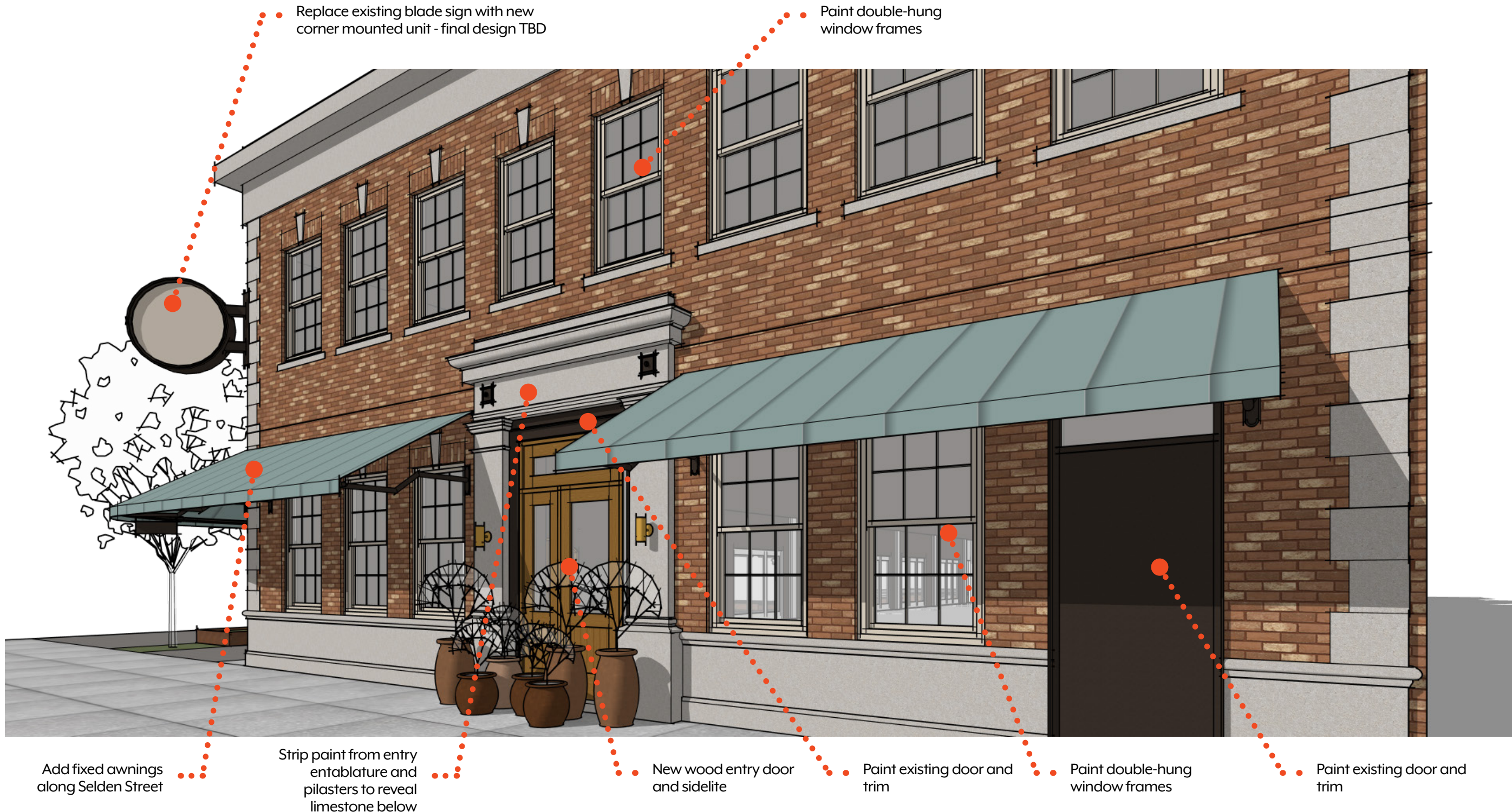



# Proposed Views | Perspective looking Northeast

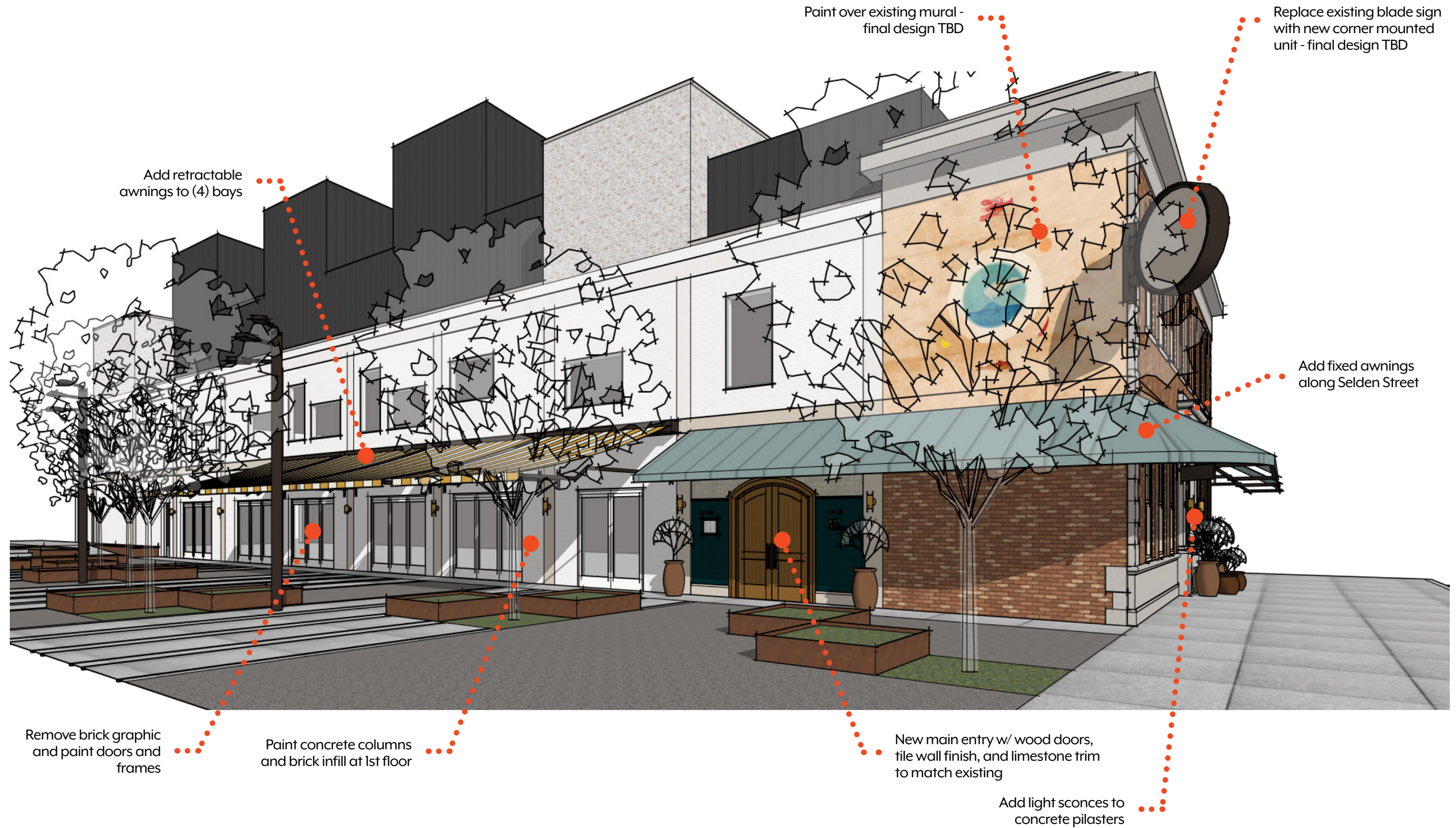



# Proposed Finishes - West Facade



Retractable awnings:  
Sailrite canvas / Big Sur Sunny



Repaint existing painted brick:  
Benjamin Moore / Decora White

Miscellaneous Hardware:  
Sherwin Williams / Tricorn Black



Paint existing painted columns:  
Benjamin Moore / Muslim

Exterior sconces on columns:  
Remains / Can / Polished Brass



Tile Entry:  
Design & Direct Source /  
Santos Heritage / Crema  
and Dark Blue



Exterior picture light:  
Lumens / Terrace /  
Sign Light

Stone Trim:  
Limestone to match  
existing color

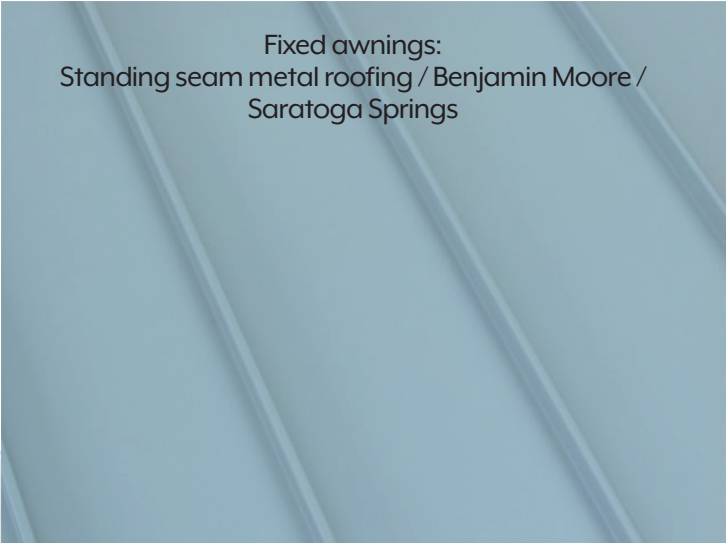

Fixed awnings:  
Standing seam metal roofing / Benjamin Moore /  
Saratoga Springs

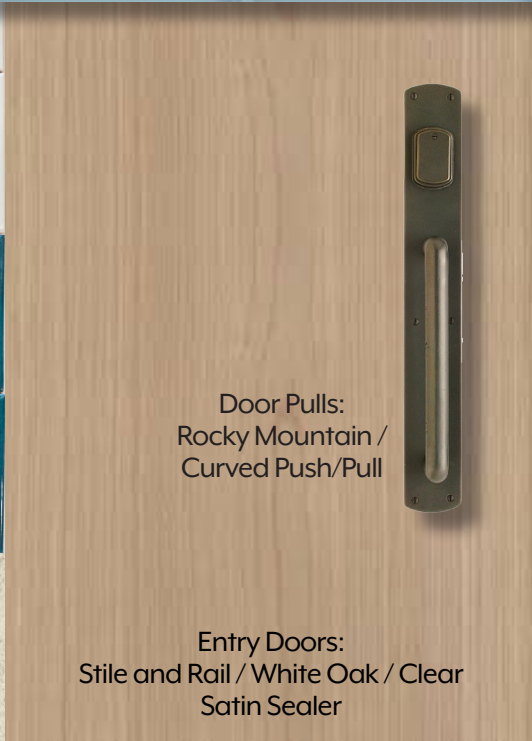

Door Pulls:  
Rocky Mountain /  
Curved Push/Pull

Entry Doors:  
Stile and Rail / White Oak / Clear  
Satin Sealer



Existing Brick:  
Existing condition to remain

# Proposed Finishes - South Facade

Fixed awnings:  
Standing seam metal roofing / Benjamin Moore /  
Saratoga Springs

Miscellaneous Trim:  
Sherwin Williams /  
Tricorn Black

Paint existing window frames:  
Benjamin Moore / Muslim

Exterior sconces on  
columns:  
Remains / Can /  
Polished Brass

Door Pulls:  
Rocky Mountain /  
Curved Push/Pull

Entry Doors:  
Stile and Rail / White Oak /  
Clear Satin Sealer

Existing Brick:  
Existing condition to remain

Remove paint and  
restore limestone  
entablature

## Product Cut Sheets - Applied Finishes (Paints)

### Benjamin Moore

Decorator's White / PM-3 (OC-149)  
Sheen TBD

Used at existing brick infill on West Facade

### Benjamin Moore

Saratoga Springs / 1669  
Sheen TBD

Used at proposed fixed canopy, standing seam metal roofing on West and South Facades

### Benjamin Moore

Muslin / 1037  
Sheen TBD

Used at existing concrete columns on West Facade and existing window frames on South Facade

### Sherwin Williams

Tricorn Black / SW6258  
Sheen TBD

Used at canopy structures and miscellaneous trim and door on West and South Facades



## Product Cut Sheets - Applied Finishes (Tile)

### Santos Heritage Field - Crema Glossy



#### Product Description

A favorite at DDS due to the wide range of colors, sizes, and many coordinating trims. Dozens of colors available with a range of variation, including some mottling and fabric textured surfaces. Samples stocked in 2x4" or 4x4", other sizes and formats available by special request.

Quick Ship Option: Select Santos Heritage Field colors are available from US stock in 3x6in, 4x4in, and Mini Half Round 0.6x6in and starting at \$8.85/SF. All other colors and sizes ship factory direct. Contact for details.

[View other products in this collection](#)

<b>Material</b>	Glazed Ceramic
<b>Finish</b>	Glossy/Polished
<b>Nominal Sizes</b>	2x2, 2x4, 2x8, 4x4, 3x6, 6x6, 4x8, 7 hexagon, 5 scallop, extensive range of specialty shapes and mosaics, trims
<b>Availability</b>	Stocked USA (Some Colors/Sizes)



contact us to request free sample

**503.525.0600**  
info@ddstile.com

#### Tech Specs

<b>Looks</b>	Transparent Glaze	<b>Surface</b>	Flat
<b>Format</b>	Mosaic, Small Format	<b>Shape</b>	Fan/Scale, Hexagon, Irregular/Unique, Rectangle, Rhombus/Diamond, Round, Square
<b>Color Family</b>	Cream/Beige	<b>Available Trims</b>	Bullnose, Cove Base, Liner, Moulding, Quarter Round, Specialty

### Santos Heritage Field - Dark Blue Glossy



#### Product Description

A favorite at DDS due to the wide range of colors, sizes, and many coordinating trims. Dozens of colors available with a range of variation, including some mottling and fabric textured surfaces. Samples stocked in 2x4" or 4x4", other sizes and formats available by special request.

A selection of Heritage Field colors are stocked in the US for projects requiring smaller quantities and/or short lead times.

[View other products in this collection](#)

<b>Material</b>	Glazed Ceramic
<b>Finish</b>	Glossy/Polished
<b>Nominal Sizes</b>	2x2, 2x4, 2x8, 4x4, 3x6, 6x6, 4x8, 7 hexagon, 5 scallop, extensive range of specialty shapes and mosaics, trims
<b>Availability</b>	Import (Made to Order)



contact us to request free sample

**503.525.0600**  
info@ddstile.com

#### Tech Specs

<b>Looks</b>	Transparent Glaze	<b>Surface</b>	Flat
<b>Format</b>	Mosaic, Small Format	<b>Shape</b>	Fan/Scale, Hexagon, Irregular/Unique, Rectangle, Rhombus/Diamond, Round, Square
<b>Color Family</b>	Blue	<b>Available Trims</b>	Bullnose, Cove Base, Liner, Moulding, Quarter Round, Specialty

Product Cut Sheets - Door Hardware (Pulls)



Curved Push/Pull Set

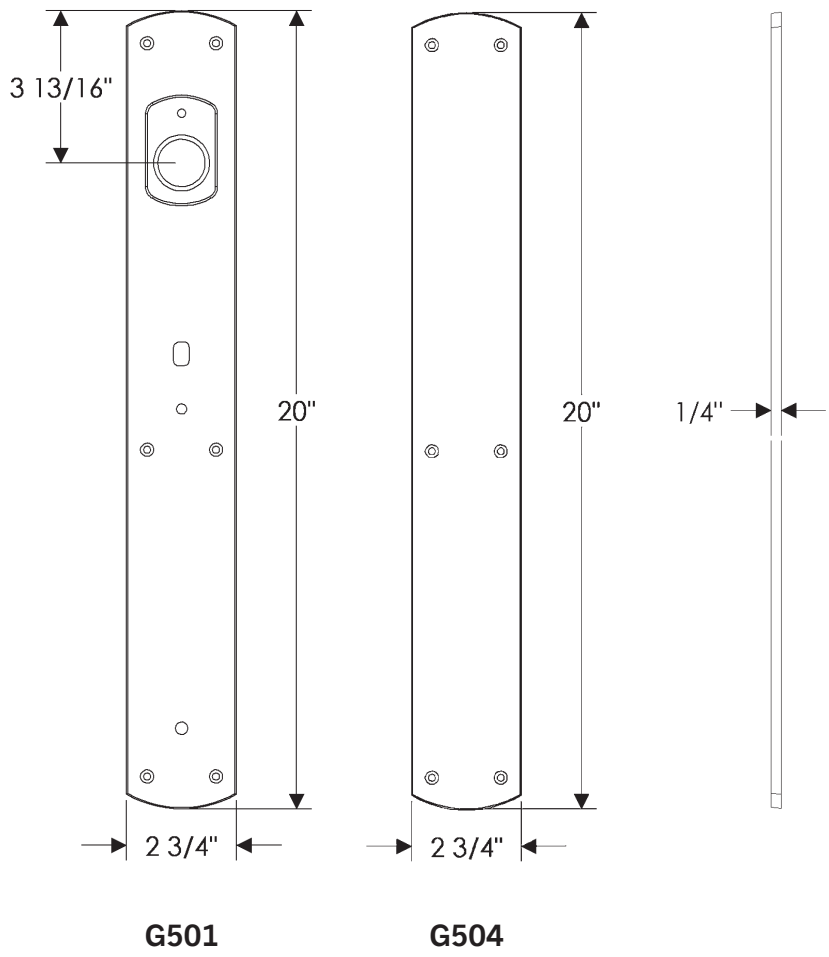

Also applicable for the G502.

	A	B	C	D	E	F	lbs/ea
DH6	6"	6 3/4"	3/4"	2"	2 13/16"	3/4"	1.50
G609	8"	9"	1"	2"	3"	1"	3.00
G619	10"	11"	1"	2"	3"	1"	3.75
G628	12"	12 7/8"	7/8"	2 15/16"	3 13/16"	7/8"	3.00
G629	18"	18 7/8"	7/8"	2 15/16"	3 13/16"	7/8"	4.00
G636	30"	31 1/8"	1 1/8"	2 1/8"	3 1/4"	1 1/8"	11.00

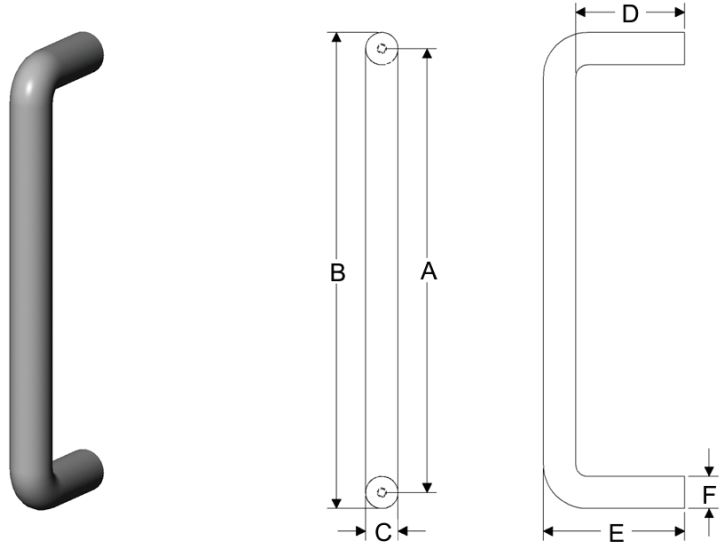

FINISH OPTIONS



## Product Cut Sheets - Lighting



### CAN EXTERIOR WALL DOWNLIGHT

#### COMMUNE COLLECTION

A solid brass exterior sconce handcrafted to order in solid heavy, brass, with a simple cylindrical body, connected to a coped round arm and backplate with slotted countersunk screws.

#### DIMENSIONS

Overall: 10" h. x 5" w. x 7-1/8" d.  
 Backplate: 5" diameter  
 Shade: 4" diameter

#### APPLICATION

UL listed for use in dry, damp, or wet environments.

#### LAMPING

Single Edison socket, maximum 100 watts  
 Also available with GU24 sockets  
 A19 Edison bulb recommended

#### JUNCTION BOX

4" x 4" junction box recommended

#### OPTIONS

Additional finishes available upon request.  
 Contact us to learn more about customization options.

#### AVAILABLE FINISHES

- \$1360 Polished Brass
- \$1515 Dark Waxed Bronze, Polished Nickel

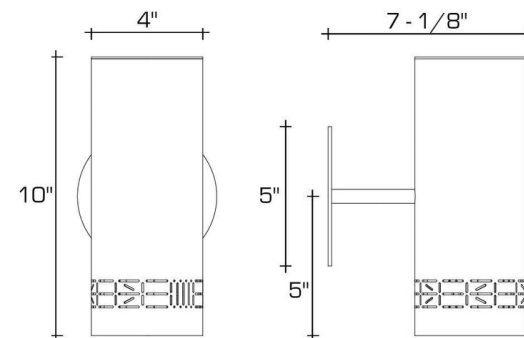

### Terrace LED Sign Light By Hinkley



Terrace LED Sign Light  
By Hinkley

#### Product Options

Finish: Museum Bronze,  
Size: 28 Inch

#### Details

Linear head rotates 360 degrees for precise adjustments  
 Dimmable with CL dimmer  
 Wiring kit is supplied

#### Dimensions

28 Inch Option Fixture: Width 28.25", Height 5.25",  
Depth 12", Weight 34.25Lbs

Lighting  
28 Inch

Lamp Type	LED Built-in
Total Lumens	2400
Total Watts	25.00
Volts	120
Color Temp	3000 (Soft White)
CRI	95
Equivalent Halogen, CFL or LED Bulb Can Be Used	No



Notes:

Prepared by:

Prepared for:  
Project:  
Room:  
Placement:  
Approval:

#### Additional Details

Product URL:  
<https://www.lumens.com/terrace-led-sign-light-by-hinkley-HKY2394791.html>  
 Rating: UL Listed Wet

ITEM#: HKY2394791



# Product Cut Sheets - Retractable Awnings

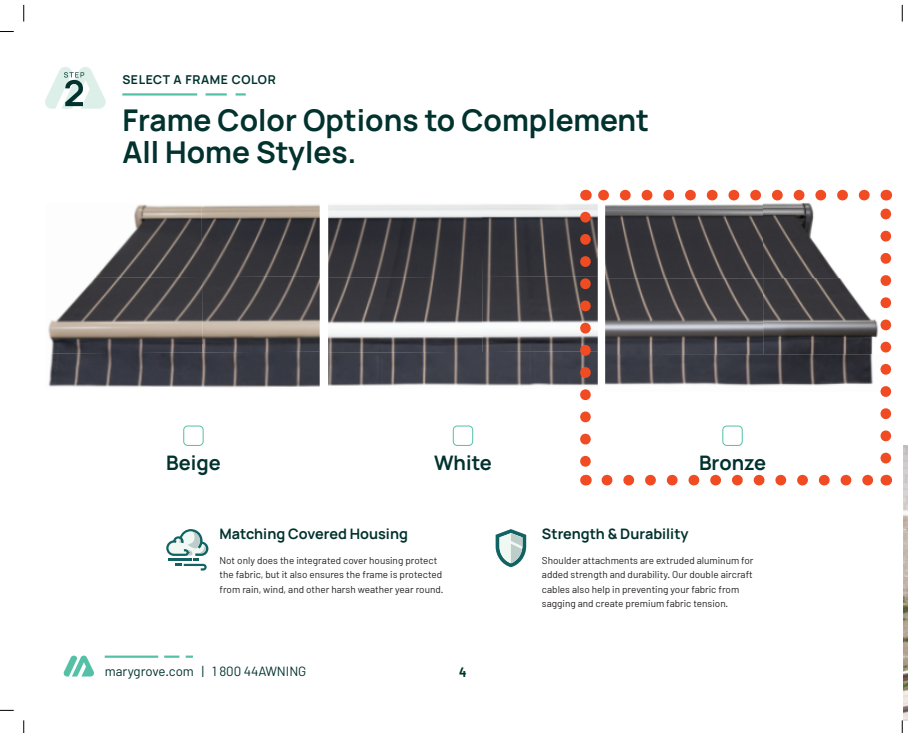
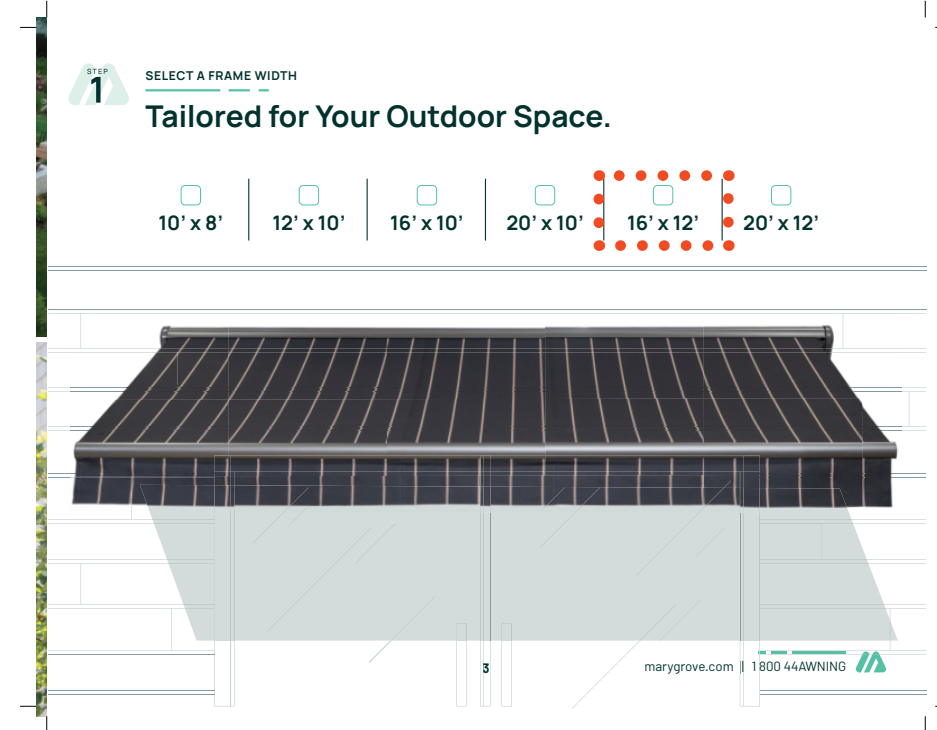

**Sattler® Big Sur Sunny 60" Awning Fabric (9614)**

SKU: 125747 ☆☆☆☆☆ 0 Reviews

**\$25.95**

Sale Unit: Yard

Available: 56

Quantity:

**Add To Cart**

WISHLIST | ORDER SAMPLE

Fabric Calculator

**Thank *You.***



## Existing Conditions



Looking Northeast from Selden Street



Looking North from Selden Street



Looking Northwest from Selden Street



Looking North from Selden Street (existing painted limestone main entry; existing double hung aluminum frame windows w/ white frame)



## Existing Conditions



Looking Northeast from Selden (existing West facing mural and South facing blade sign)



Looking North from courtyard (subject building on right)



Looking South from courtyard (subject building on left; existing glazing graphic detail; typical on 1st and 2nd floor West facade)



Looking East from courtyard (existing painted brick and glazing graphic detail; typical on 1st and 2nd floor West facade)



# Proposed Views | ISO looking Northeast

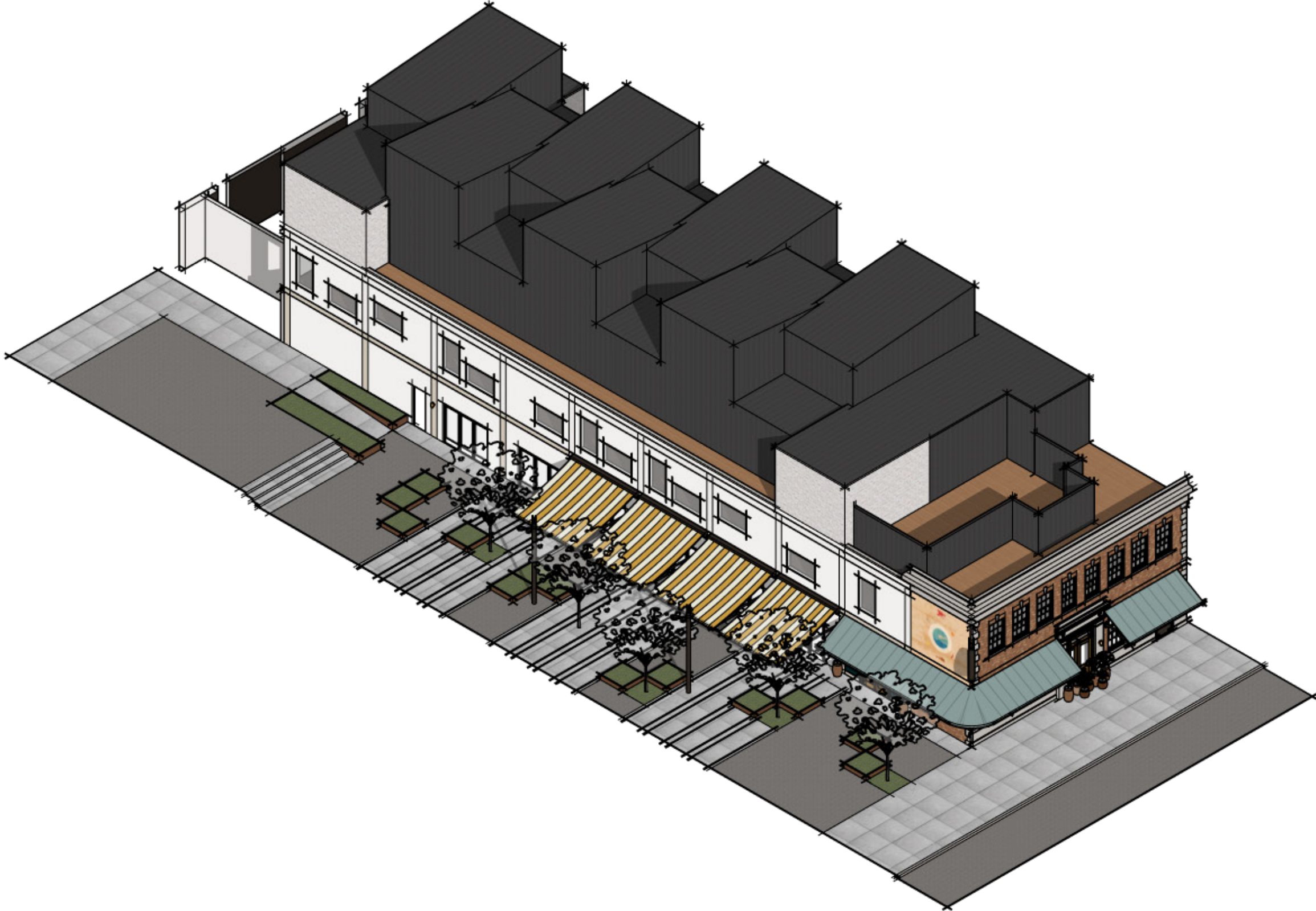



# Proposed Views | South Elevation

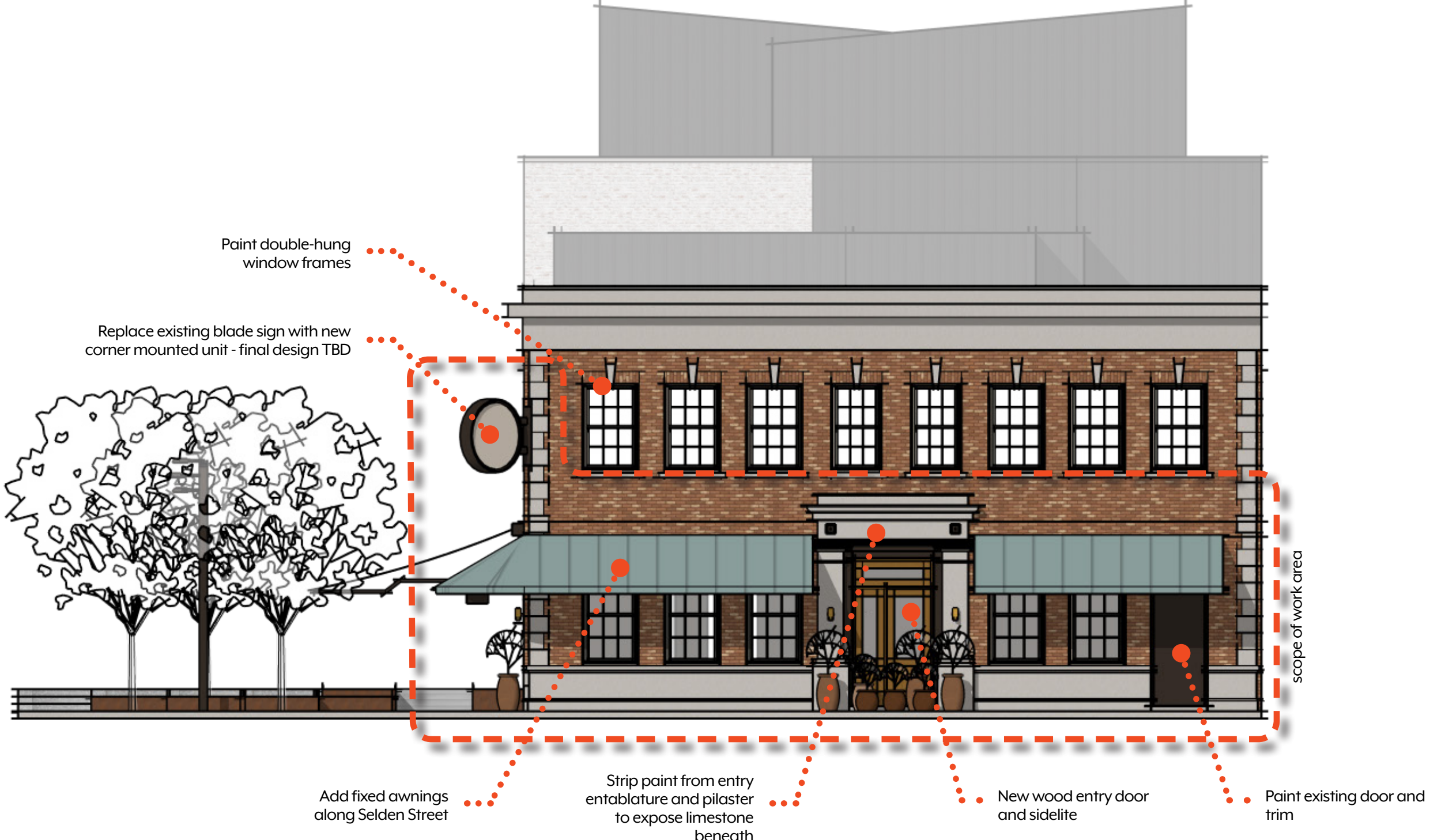

# Proposed Views | West Elevation

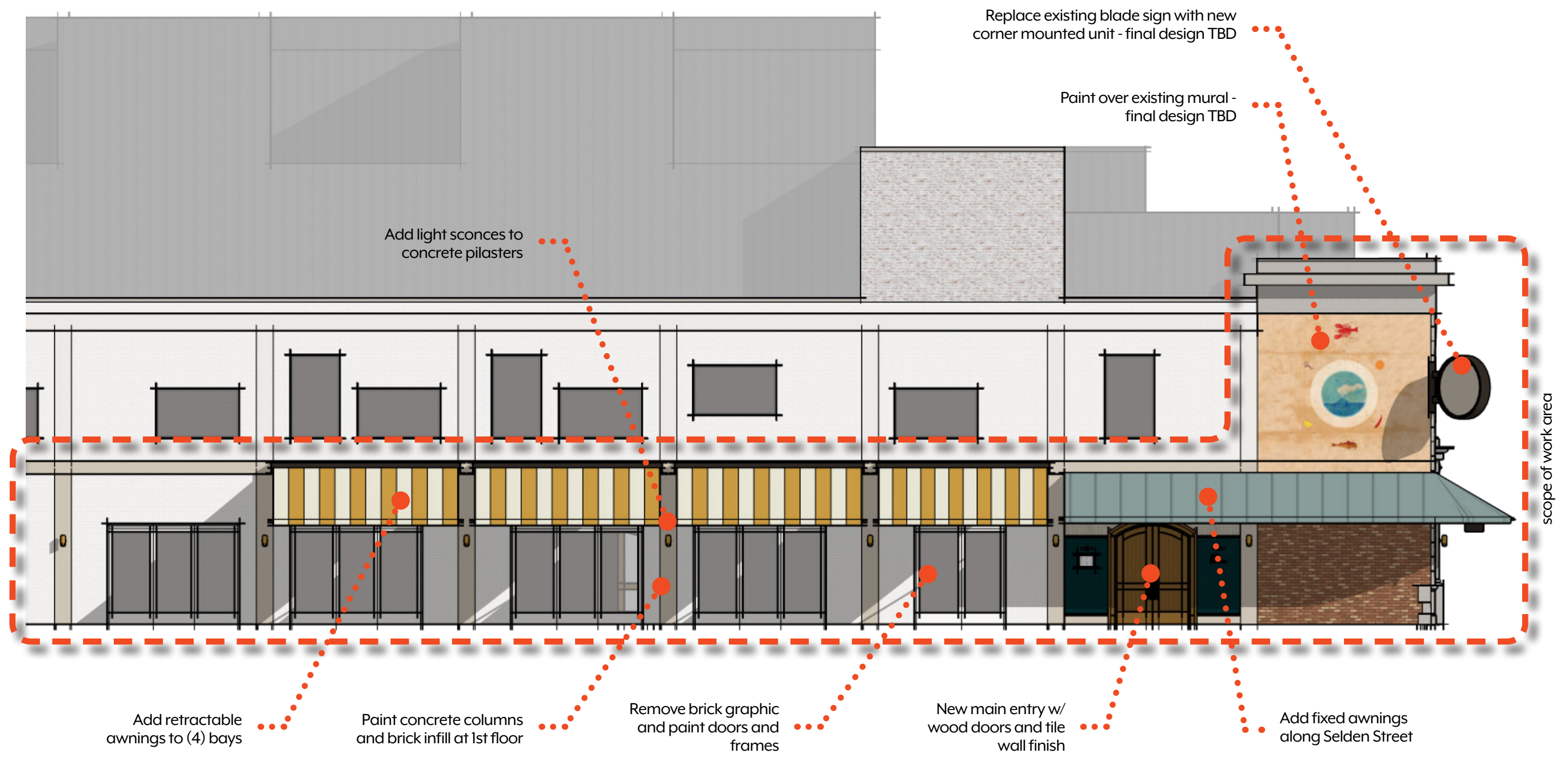



# Proposed Views | Perspective looking Northwest

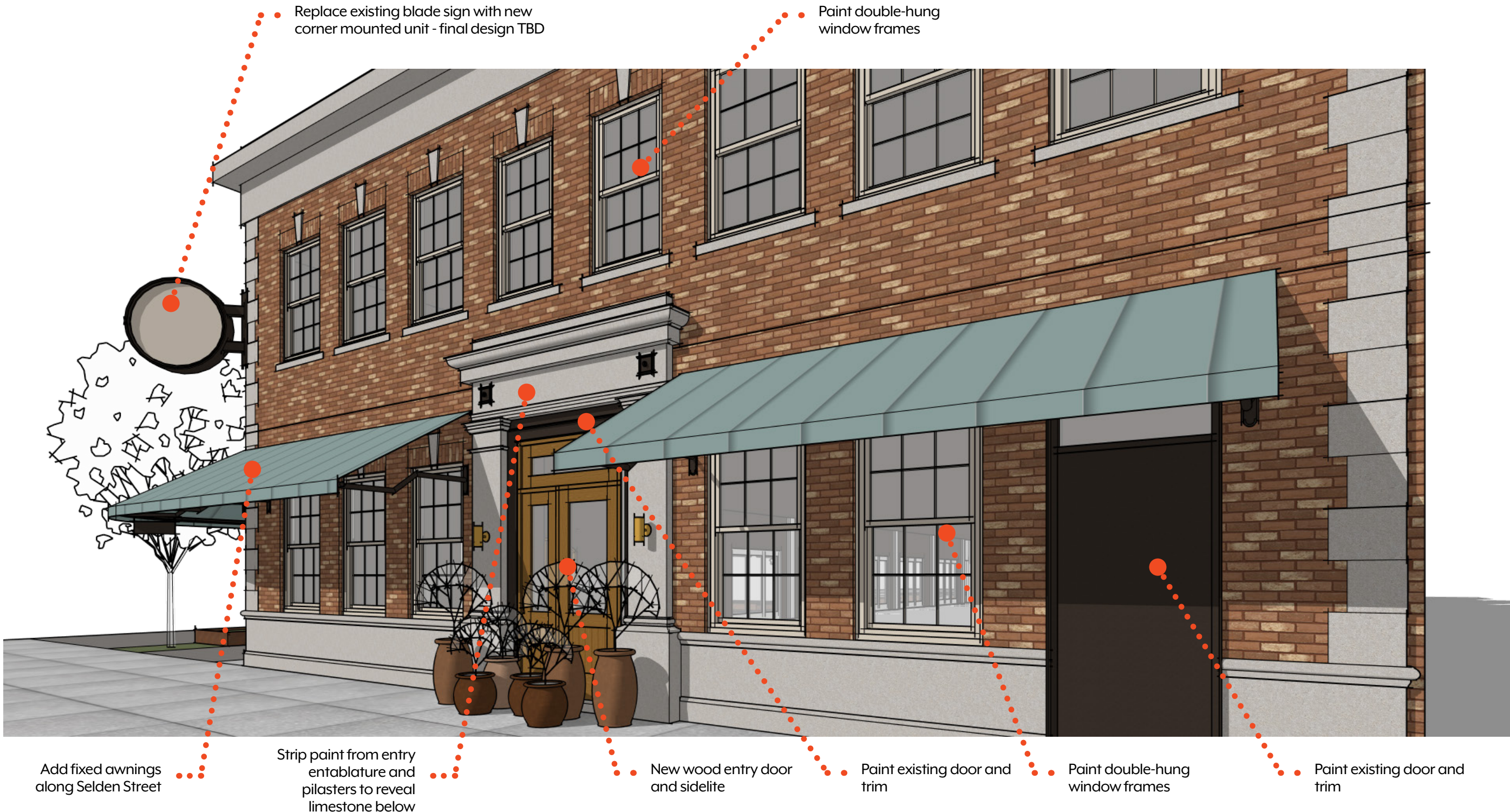



# Proposed Views | Perspective looking Northeast

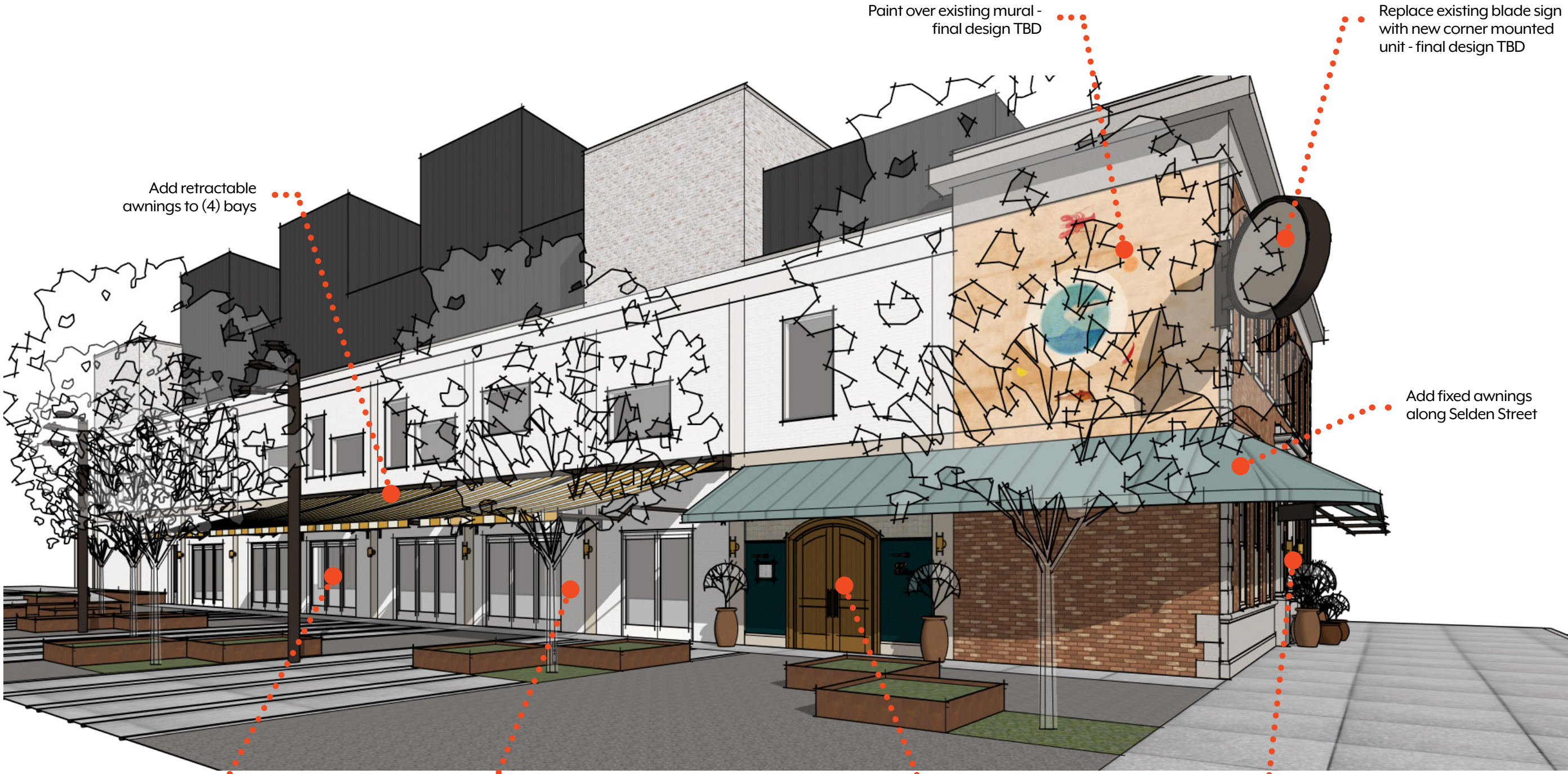

Add retractable awnings to (4) bays

Paint over existing mural - final design TBD

Replace existing blade sign with new corner mounted unit - final design TBD

Add fixed awnings along Selden Street

Remove brick graphic and paint doors and frames

Paint concrete columns and brick infill at 1st floor

New main entry w/ wood doors, tile wall finish, and limestone trim to match existing

Add light sconces to concrete pilasters