

# HDC2024-00519

## APPROVAL DOCUMENT – POST AT WORK LOCATION

CITY OF DETROIT  
HISTORIC DISTRICT COMMISSION

2 WOODWARD, SUITE 808  
DETROIT, MICHIGAN 48226

10/15/2024

### CERTIFICATE OF APPROPRIATENESS

William Barbour-Keir  
Mark Johnson & Associates  
7310 Kingswood  
Bloomfield Hills, MI 48301

**RE: Application Number HDC2024-00519; 3628-3644 Lincoln; Woodbridge Farm Historic District  
Scope: Demolish rear wings, construct new rear addition, rehabilitate exterior, demolish garage, erect new carriage house.**

Dear Applicant,

At the Regular Meeting that was held on October 9, 2024, the Detroit Historic District Commission (“DHDC”) reviewed the above-referenced application. Pursuant to Section 5(1) of the Michigan Local Historic District Act, as amended, being MCL 399.205 (1) and Sections 21-2-73/21-2-78 of the 2019 Detroit City Code; the DHDC hereby issues a Certificate of Appropriateness (“COA”) for the following work, effective on October 15, 2024, as it meets the Secretary of Interior’s Standards for Rehabilitation and the district’s Elements of Design:

- *Per the attached drawings and documentation; demolish rear wings, construct new rear addition, rehabilitate exterior, demolish garage, erect new carriage house.*

*With the condition that:*

- *The exteriors of the rear addition (including the “hyphen”) and the carriage house/garage be designed in a simplified architectural vocabulary distinct from the Italianate style of the main nineteenth-century house, subject to HDC staff approval.*

Please retain this COA for your files and post it at the subject property until work is complete. It is important to note that approval by the DHDC does not waive the applicant's responsibility to comply with any other applicable ordinances or statutes. If you have any questions regarding the foregoing, please contact staff at 313-224-1762 or [hdc@detroitmi.gov](mailto:hdc@detroitmi.gov).

For the Commission:



Garrick B. Landsberg  
Director of Historic Preservation, Staff to the Commission

# 3644 LINCOLN

---

A Home in the Historic Woodbridge Farms District

# Permit Application Information

Permit #Res2024-03609 For Main house

and

Permit # BLD2024-01072 For Fence – Approved 4/30/2024

# Project Narrative

- The project involves the combined parcels at 3644 and 3628 Lincoln in the Woodbridge Farms Neighborhood of Detroit. The existing home, built around 1870, has a detached garage added in the 1920s. Designed in the Italianate style, the client wishes to honor this by restoring the home's original details. Their goal is to create a comfortable retirement home.
- To enhance livability, we have designed an additional structure at the rear of the building, mirroring the dimensions of the existing western section. These two sections will be connected by a smaller, complementary structure made of contrasting brick material that aligns with the existing cold storage porch wall. The main level of the new addition will extend behind the existing wall of a previously added first-floor south wing that was damaged by fire. The new addition will be mostly hidden behind the original façade to minimize its impact on the neighborhood.
- The existing western section will feature a historically accurate front parlor and living room on the first floor, with a new master suite on the second floor. The rear section will include an updated kitchen and laundry room on the main level, and two additional bedrooms on the second level for visiting adult children and guests. The original brackets on the house will be saved as much as possible and will be replicated on the new section.
- The client also would like the garage's parking capacity to be four bays. The additional space above will provide space for retirement activities and hobbies, including a storage loft above most of the garage and a mezzanine level for crafting.
- The combined lots will allow the client to create a garden, enriching both their family life and the neighborhood's visual appeal. Additionally, the client's deck will be tucked behind the addition to avoid visual intrusion on the neighborhood.
- The client would like to maintain the North side of the property for its current use as the neighborhood pedestrian pass-through.



# Photographs



WEST

Existing House



SOUTH

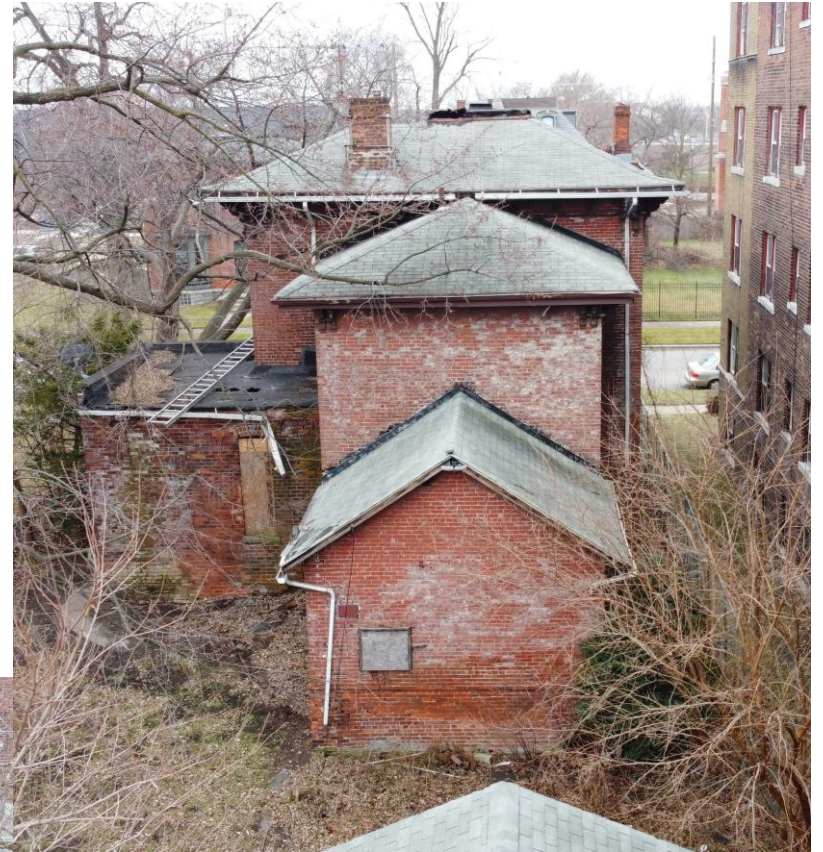

EAST





Site from above









# Saved details

From original building to be used in reconstruction

# Scaled drawings on 11x17

- Site plan
- Floor plans
- Elevations
- Sections and other details



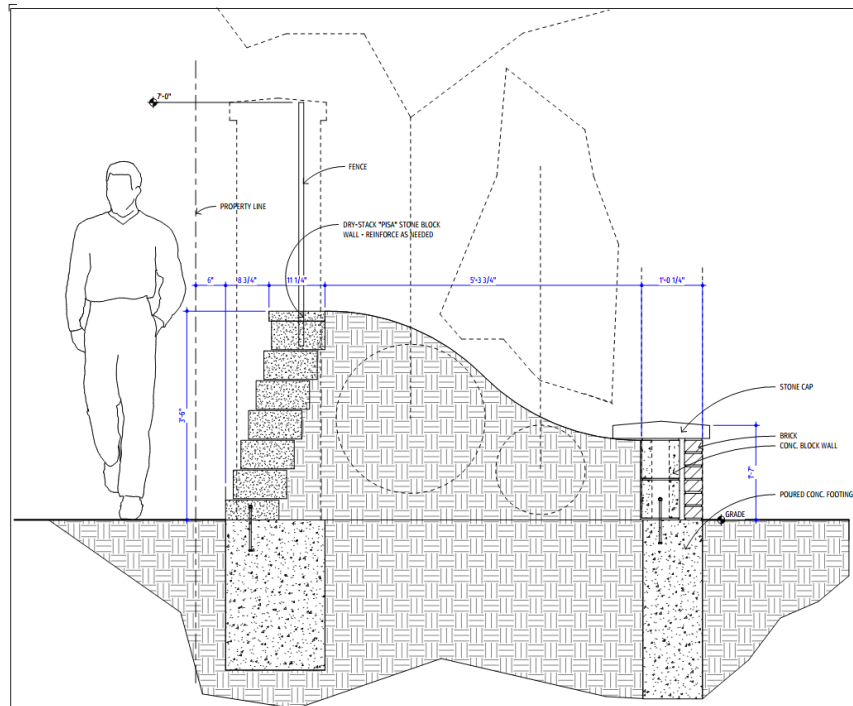

4 SECTION @ SOUTH BERM  
1" = 1'-0"

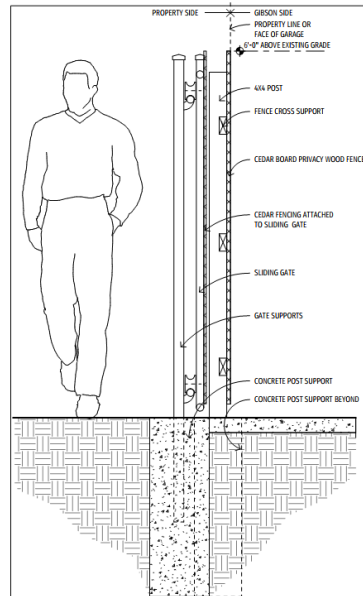

3 GATE @ REAR PARKING  
1" = 1'-0"

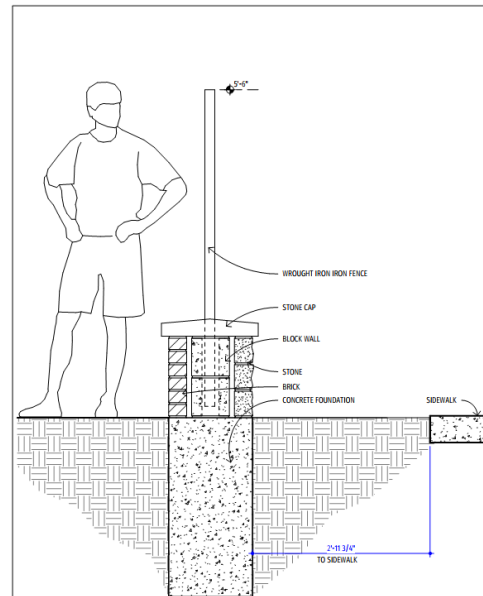

2 FENCE LINE @ SIDEWALK  
1" = 1'-0"

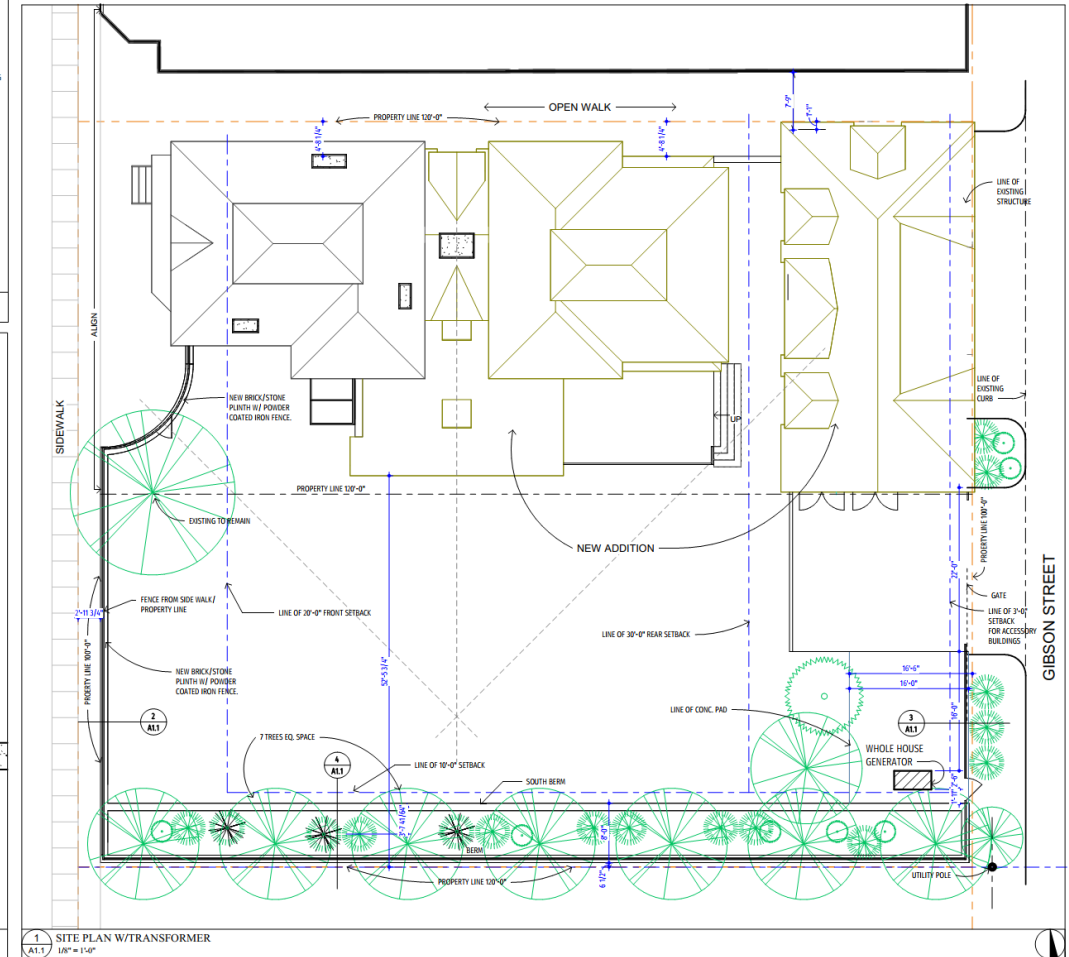

1 SITE PLAN W/TRANSFORMER  
1/8" = 1'-0"

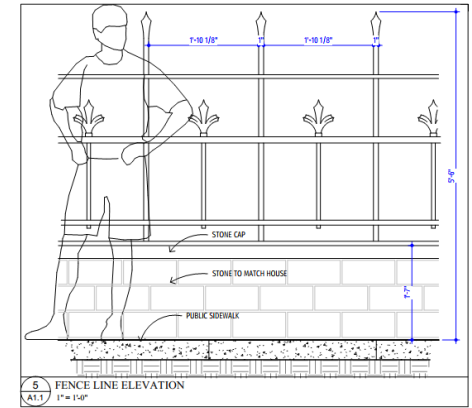

5 FENCE LINE ELEVATION  
1" = 1'-0"

Site plan

Previous submittal  
Approved 6/28/2024

Permit #  
BLD2024-01072

Mark Johnson and Associates  
7777 Woodward Ave., Suite 100  
Detroit, MI 48202  
Phone: 313-443-5411  
Fax: 313-443-5118

NO PORTIONS ARE TO BE REPRODUCED OR COPIED WITHOUT THE WRITTEN PERMISSION OF THE ARCHITECT. ALL RIGHTS ARE RESERVED. THE ARCHITECT SHALL BE RESPONSIBLE FOR THE ACCURACY AND COORDINATION OF ALL OTHER DRAWINGS.

LINCOLN AVE.  
REMODEL  
3644 LINCOLN AVE.  
DETROIT, MICHIGAN 48208

SEAL:  
P. J. Johnson  
Professional Engineer  
No. 26173  
State of Michigan

DATE:

REVISIONS:

PROJECT NUMBER:  
22007

SHEET TITLE:  
ARCHITECTURAL  
SITE PLAN

A1.1  
SHEET NUMBER:

DO NOT SCALE DRAWINGS

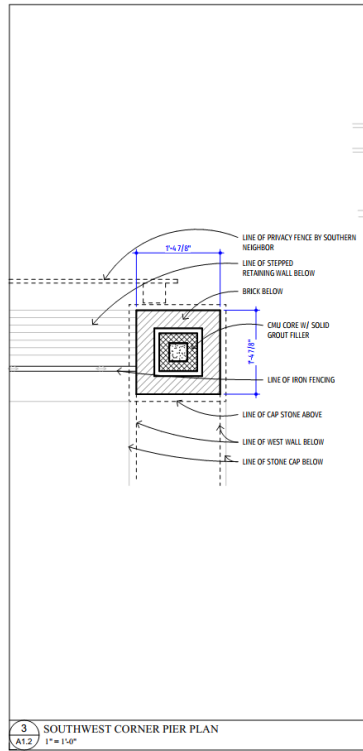

3 SOUTHWEST CORNER PIER PLAN  
1/8" = 1'-0"

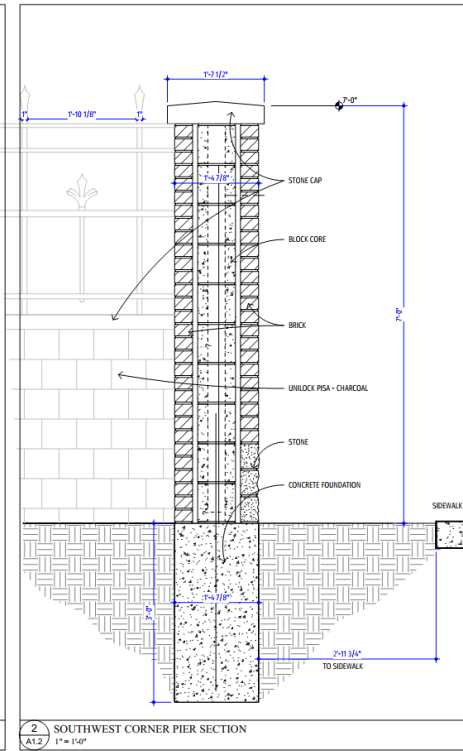

2 SOUTHWEST CORNER PIER SECTION  
1/8" = 1'-0"

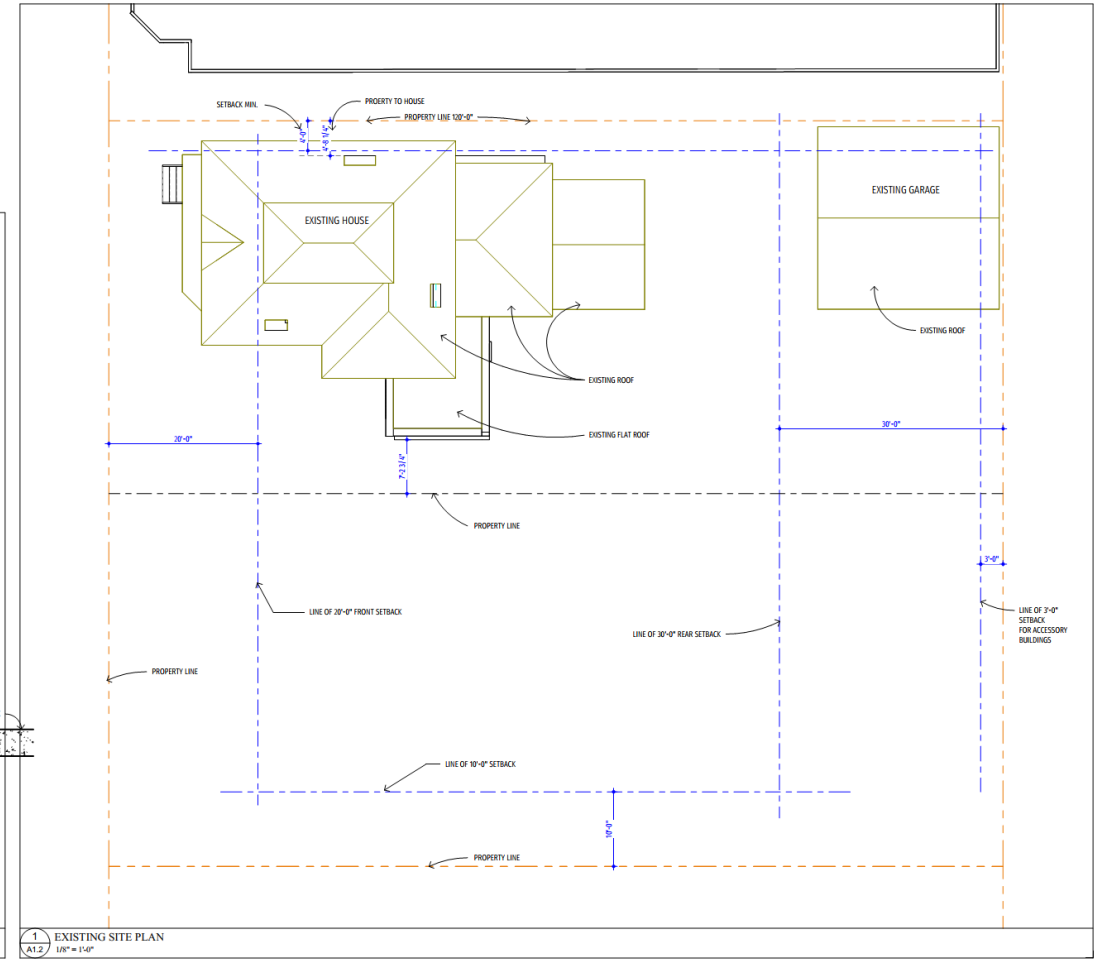

1 EXISTING SITE PLAN  
1/8" = 1'-0"

NO PORTION OF THIS DRAWING IS TO BE REPRODUCED OR TRANSMITTED IN ANY FORM OR BY ANY MEANS, ELECTRONIC OR MECHANICAL, INCLUDING PHOTOCOPYING, RECORDING, OR BY ANY INFORMATION STORAGE AND RETRIEVAL SYSTEM, WITHOUT THE WRITTEN PERMISSION OF THE ARCHITECT. ALL RIGHTS ARE RESERVED. THE ARCHITECT SHALL BE RESPONSIBLE FOR THE ACCURACY OF THE INFORMATION AND COORDINATION OF ALL OTHER DRAWINGS.

Mark Johnson and Associates  
7777 Woodward Ave., Suite 100  
Detroit, MI 48202  
Phone: 313-467-1411  
Fax: 313-467-5118

LINCOLN AVE.  
REMODEL  
3644 LINCOLN AVE.  
DETROIT, MICHIGAN 48208

SEAL:

DATE:  
08/20/24

REVISIONS:

PROJECT NUMBER:  
22007

SHEET TITLE:  
SITE DETAILS

A1.2  
SHEET NUMBER:

DO NOT SCALE DRAWINGS

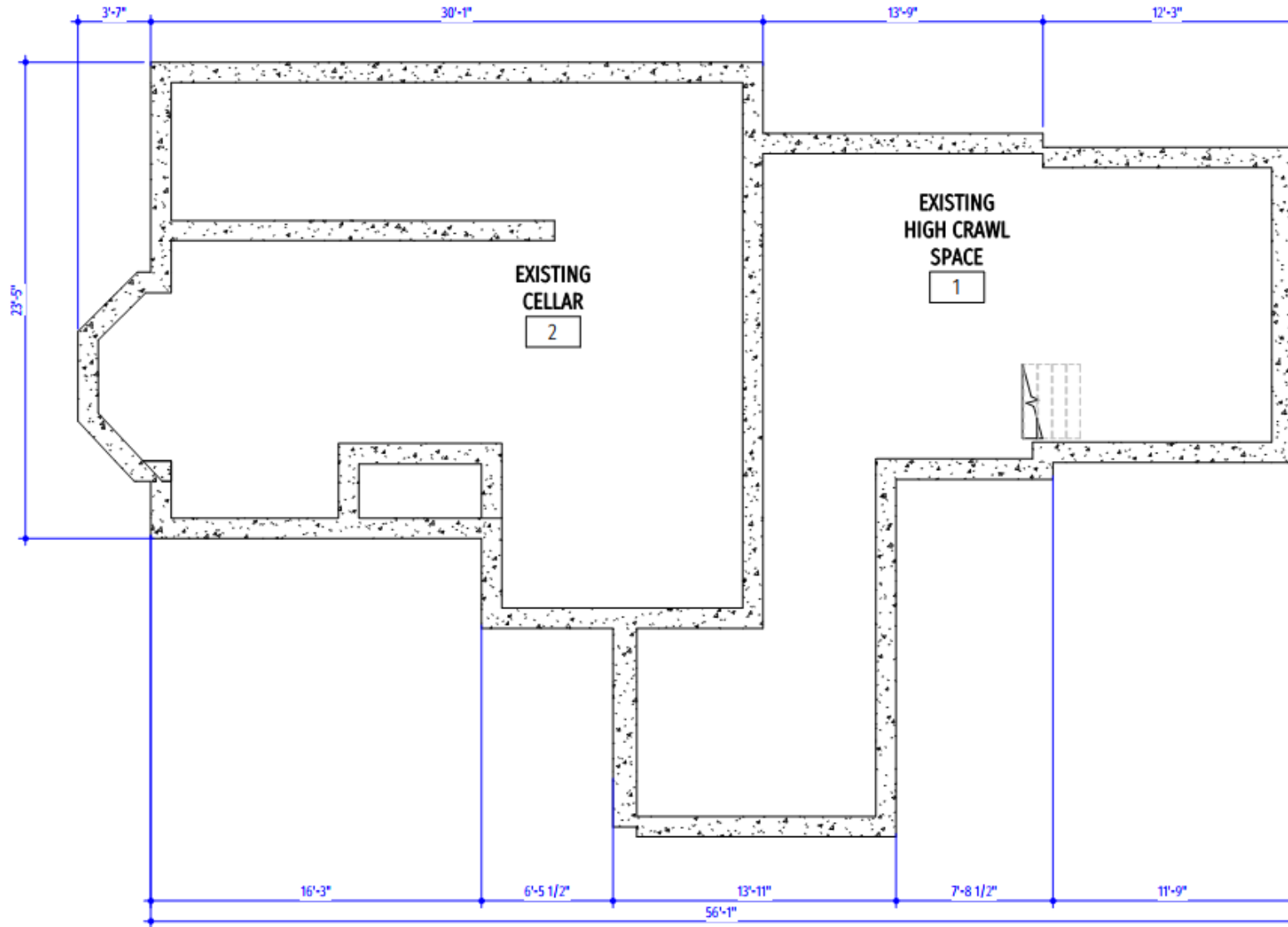

Project	Drawing	Scale	Project No.	Date	Issued For	By	Sheet Number
LINCOLN AVE.	EXISTING LOWER LEVEL PLAN	3/16" = 1'-0"	2 2 0 0 7	09/09/24	Project Status	Author	HC2.2



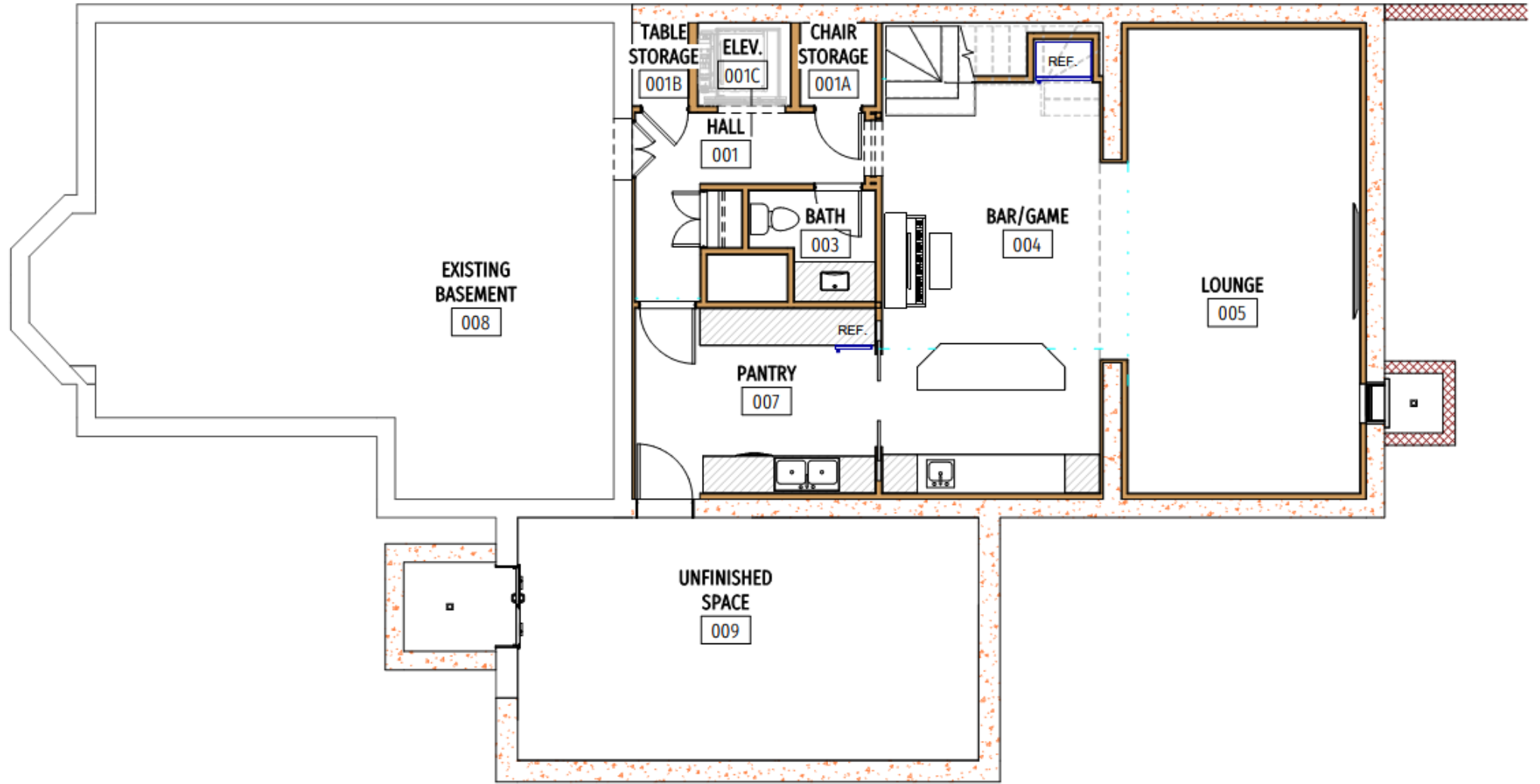

Project	Drawing	Scale	Project No.	Date	Issued For	By	Sheet Number
LINCOLN AVE.	LOWER LEVEL PROPOSED PLAN	3/16" = 1'-0"	2 2 0 7	09/06/24	Project Status	Author	HC2.1

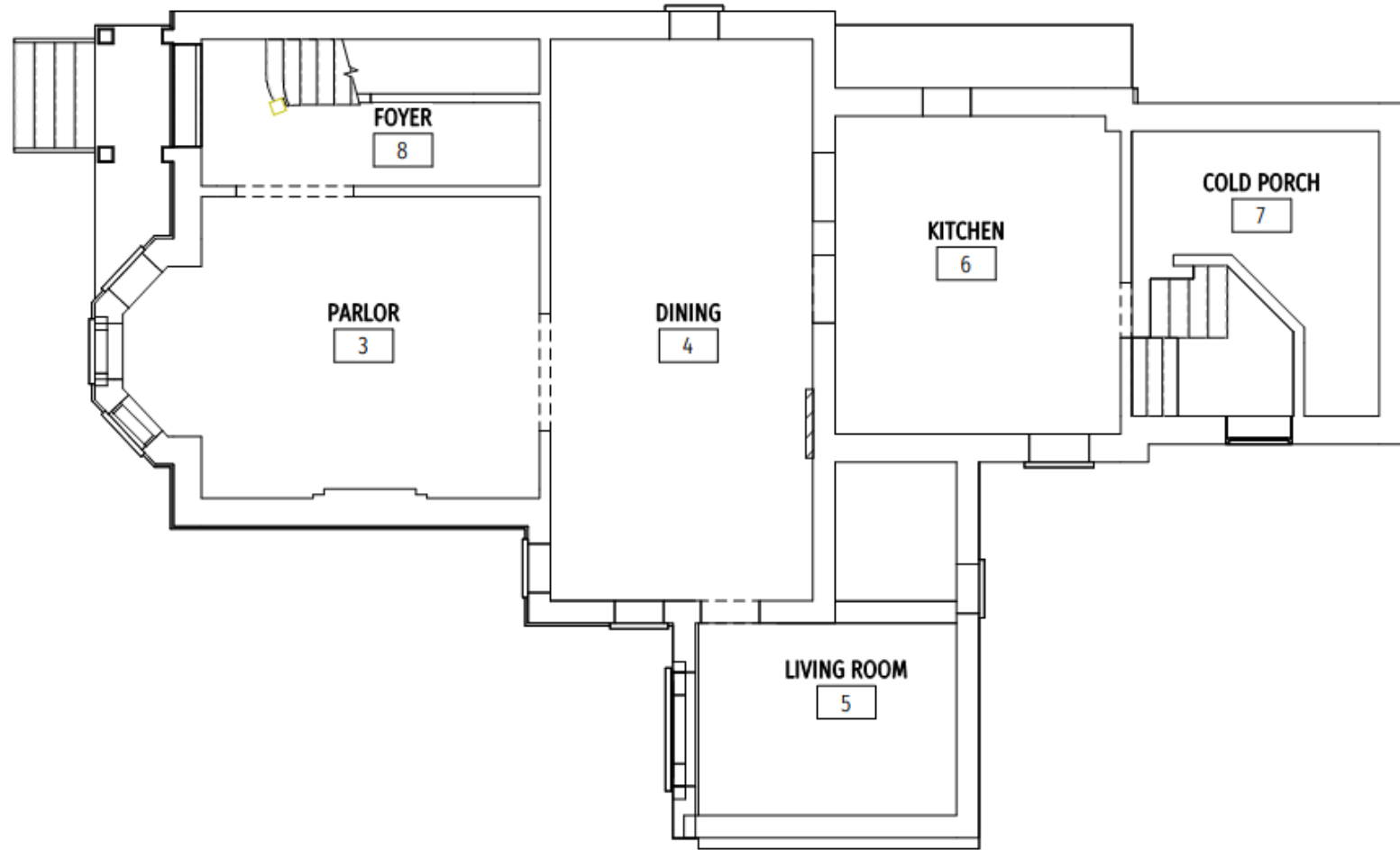

ORIGINAL PROPERTY LINE

Project	Drawing	Scale	Project No.	Date	Issued For	By	Sheet Number
LINCOLN AVE.	EXISTING MAIN LEVEL PLAN	3/16" = 1'-0"	22007	09/09/24	Project Status	Author	HC2.4

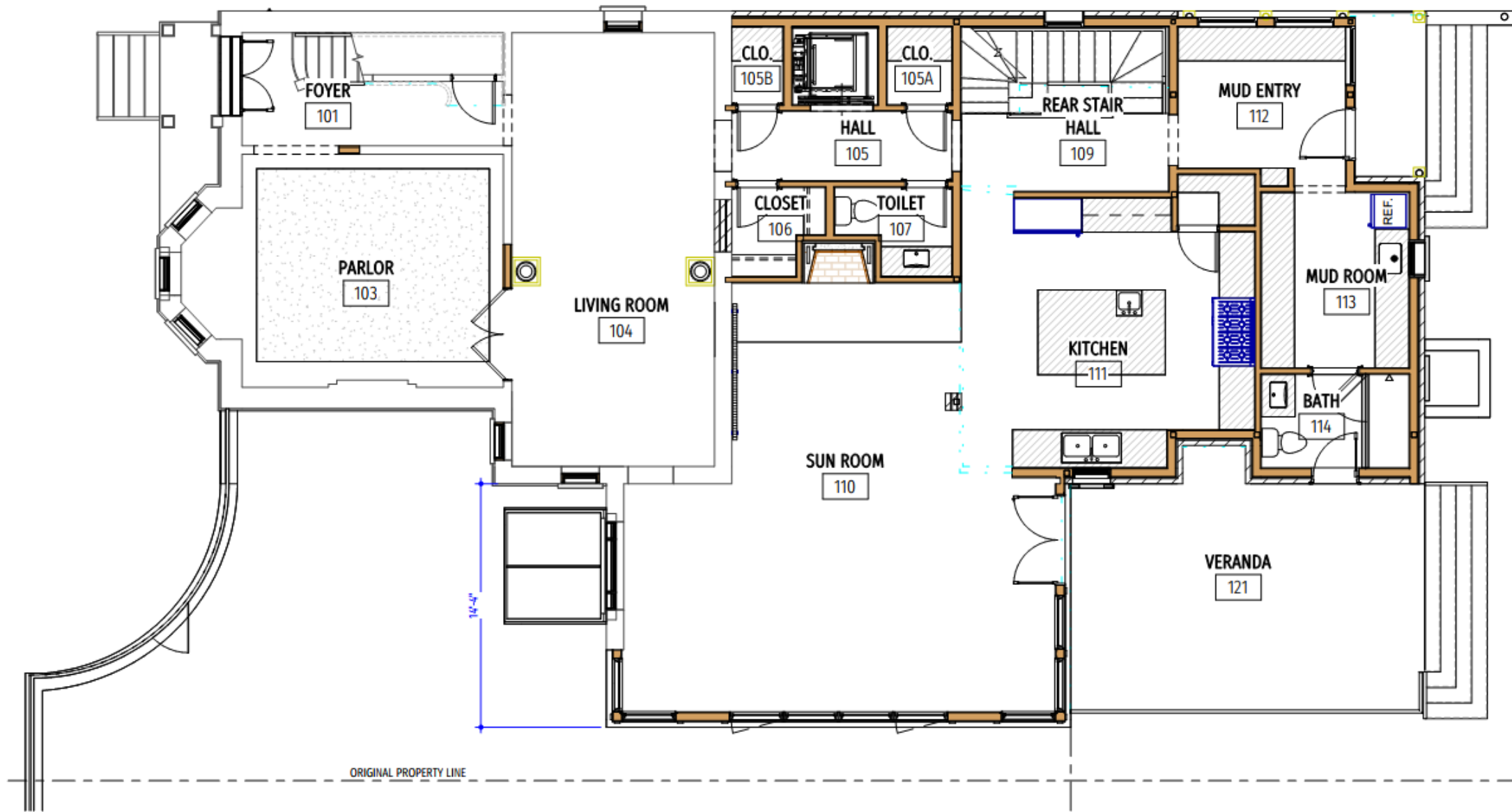

Project	Drawing	Scale	Project No.	Date	Issued For	By	Sheet Number
LINCOLN AVE.	PROPOSED MAIN LEVEL	3/16" = 1'-0"	22007	09/06/24	Project Status	Author	HC2.3

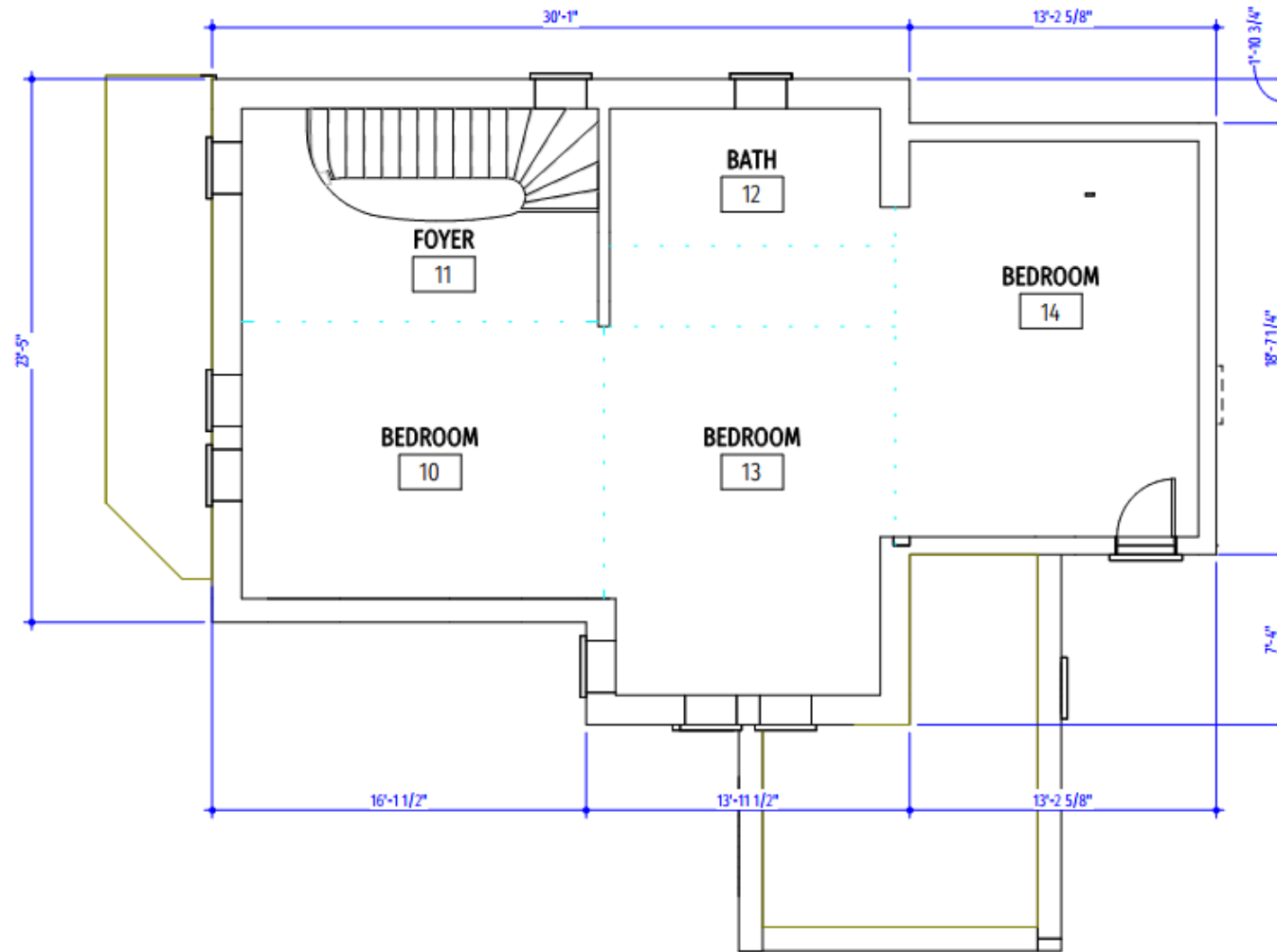

Project	Drawing	Scale	Project No.	Date	Issued For	By	Sheet Number
LINCOLN AVE.	EXISTING UPPER LEVEL FLOOR PLAN	3/16" = 1'-0"	2 2 0 0 7	09/09/24	Project Status	Author	HC2.8

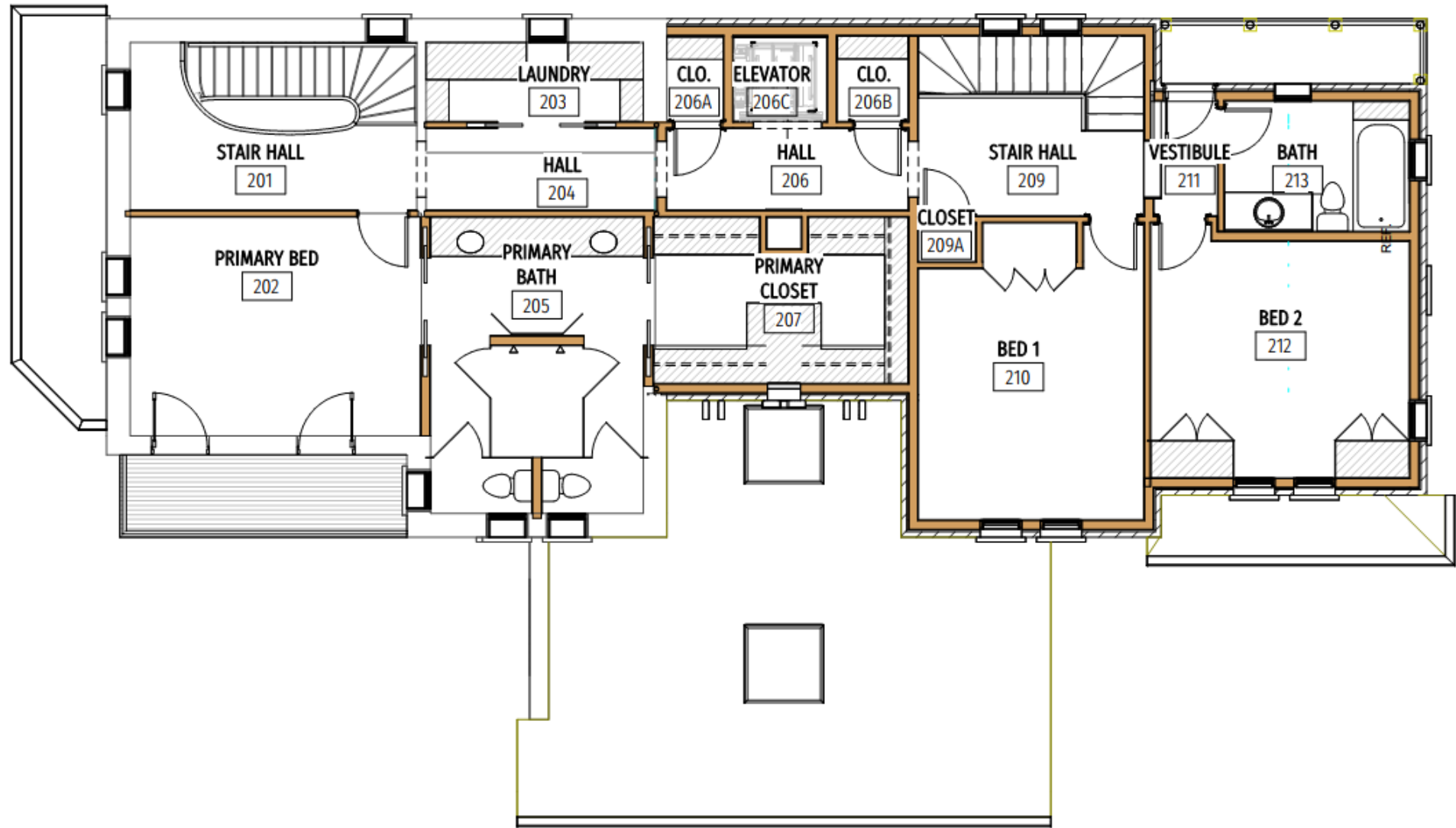

Project	Drawing	Scale	Project No.	Date	Issued For	By	Sheet Number
LINCOLN AVE.	PROPOSED UPPER LEVEL	3/16" = 1'-0"	2 2 0 7	09/06/24	Project Status	Author	HC2.7

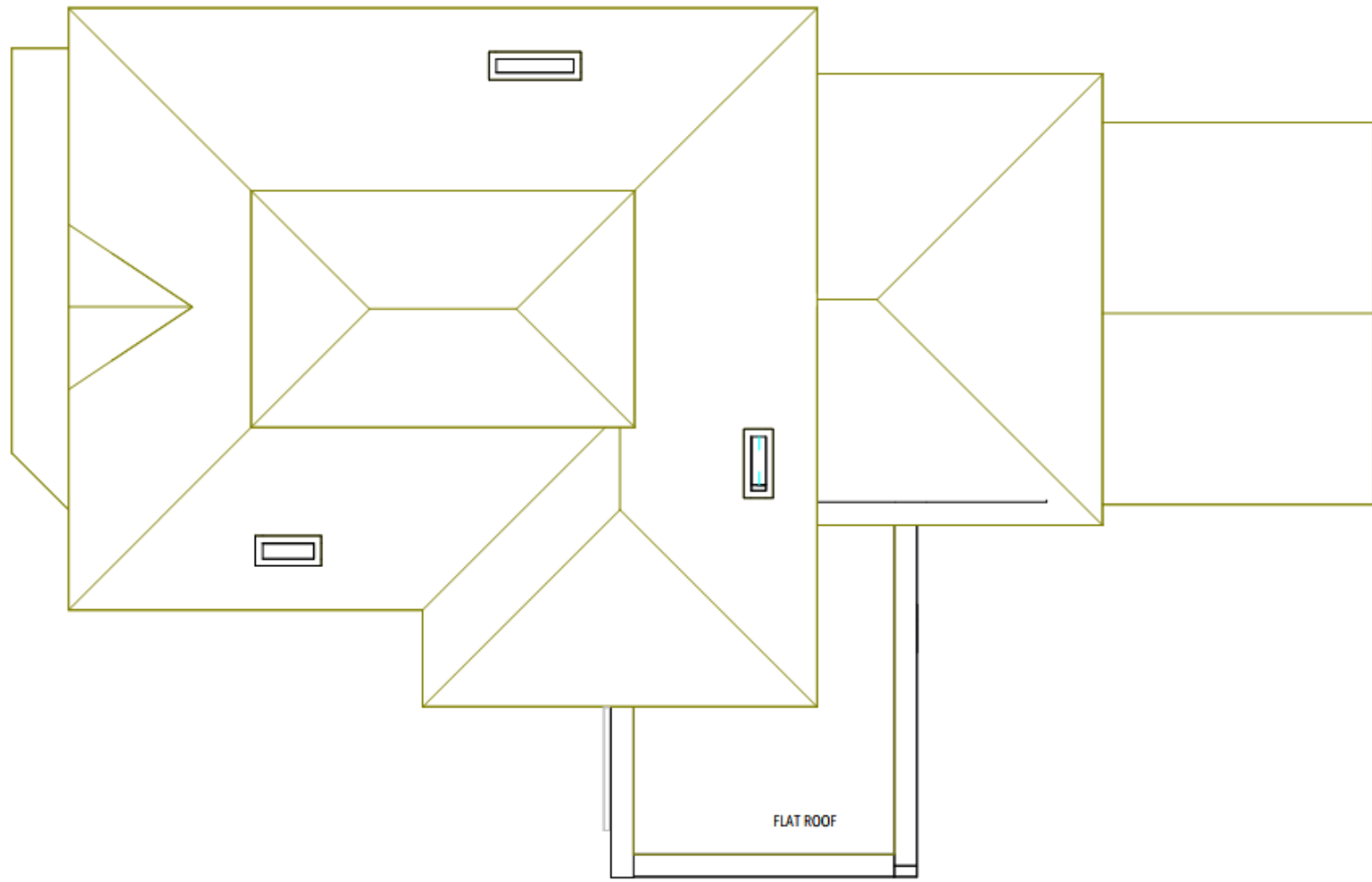

Project

LINCOLN AVE.

Drawing

EXISTING ROOF PLAN

Scale

3/16" = 1'-0"

Project No.

2 2 0 0 7

Date

09/09/24

Issued For

Project Status

By

Author

Sheet Number

HC2.12

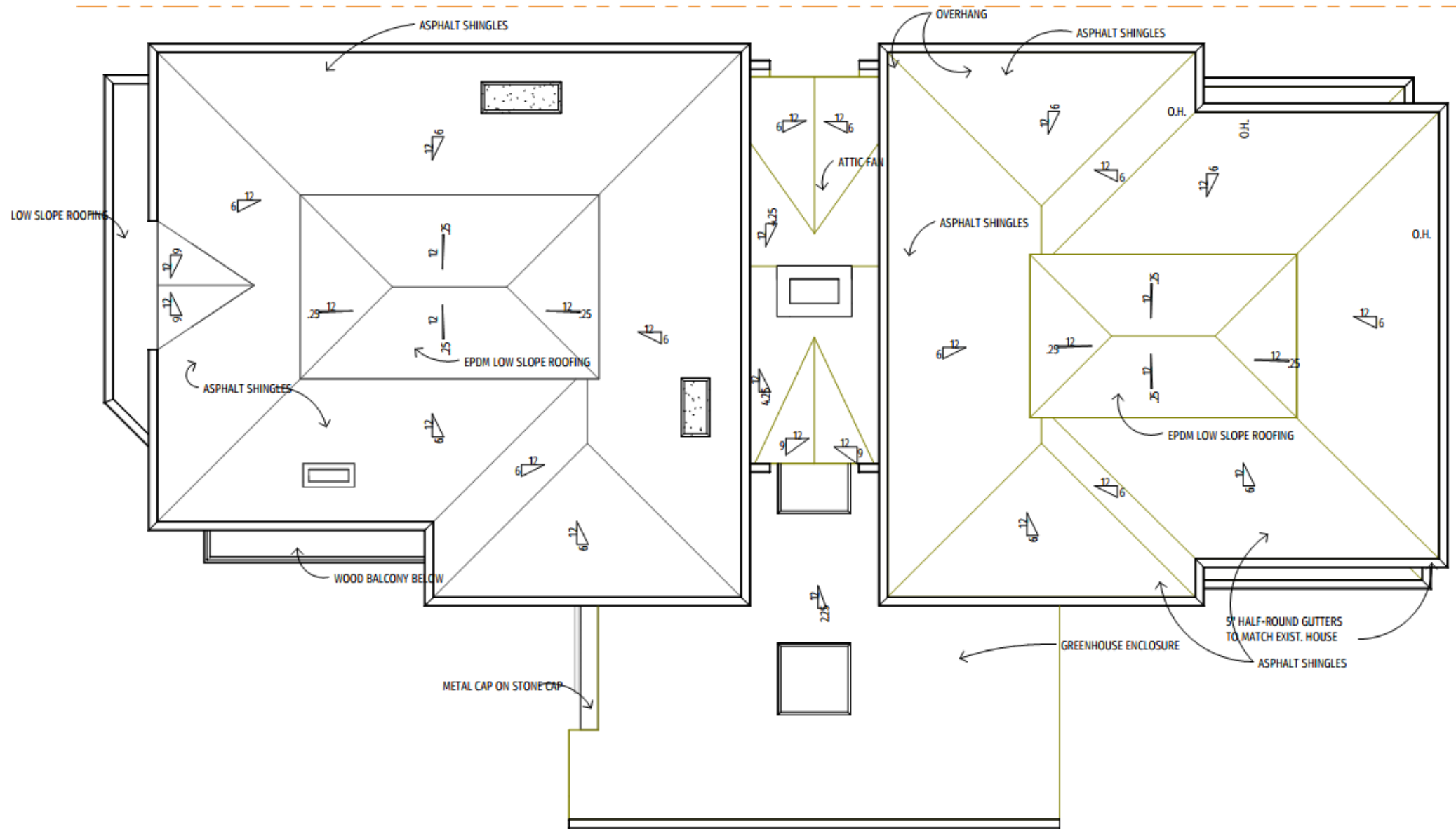

Project LINCOLN AVE.	Drawing PROPOSED ROOF PLAN	Scale 3/16" = 1'-0"	Project No. 22007	Date 09/06/24	Issued For Project Status	By Author	Sheet Number HC2.11
-------------------------	-------------------------------	------------------------	----------------------	------------------	------------------------------	--------------	------------------------

# Proposed color palette

## Main house



- **Existing brick 'A'**
- Restoration of brick at existing house



- **Existing stone 'D'**
- Existing porch water table
- Existing front bay water table
- New sunroom water table
- New window brackets and arch keystones

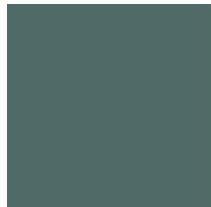

- **B:12 Grayish Green, MS:10G 4/2**
- Front Porch columns and railing
- Rear porch Columns/Railings/ Windows
- Sunroom Columns, walls, windows, brackets



- **Taupe/Beige** to match existing stone
- Front porch Brackets and Cornice
- Main house and addition Cornice
- Main house and addition Brackets
- Flat roof cresting
- Rear porch steps
- Step riders at rear stair



- **A:9 Moderate Reddish Brown MS:7.5R 3/6**
- All Window Frames and Brick Mould at Brick Openings
- Bracket Accents at Face and sides
- Panel accents at rear porch



- **B:18 Dark Reddish Brown MS:2.5YRG 2/4**
- All Window Sashes at Brick Openings
- Front Door (stained)
- Rear Porch Door (stained)



- **Brick – Reclaimed**
- @ All East addition walls to match existing house.



- **Brick – Accent 'C'**
- @ North and South walls of Re-Built connector

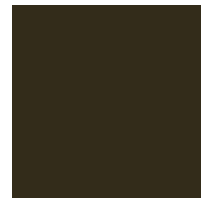

- **B:14 Dark Grayish Olive MS:10Y 2/2**
- Front and rear porch Floors
- Treads at all Steps



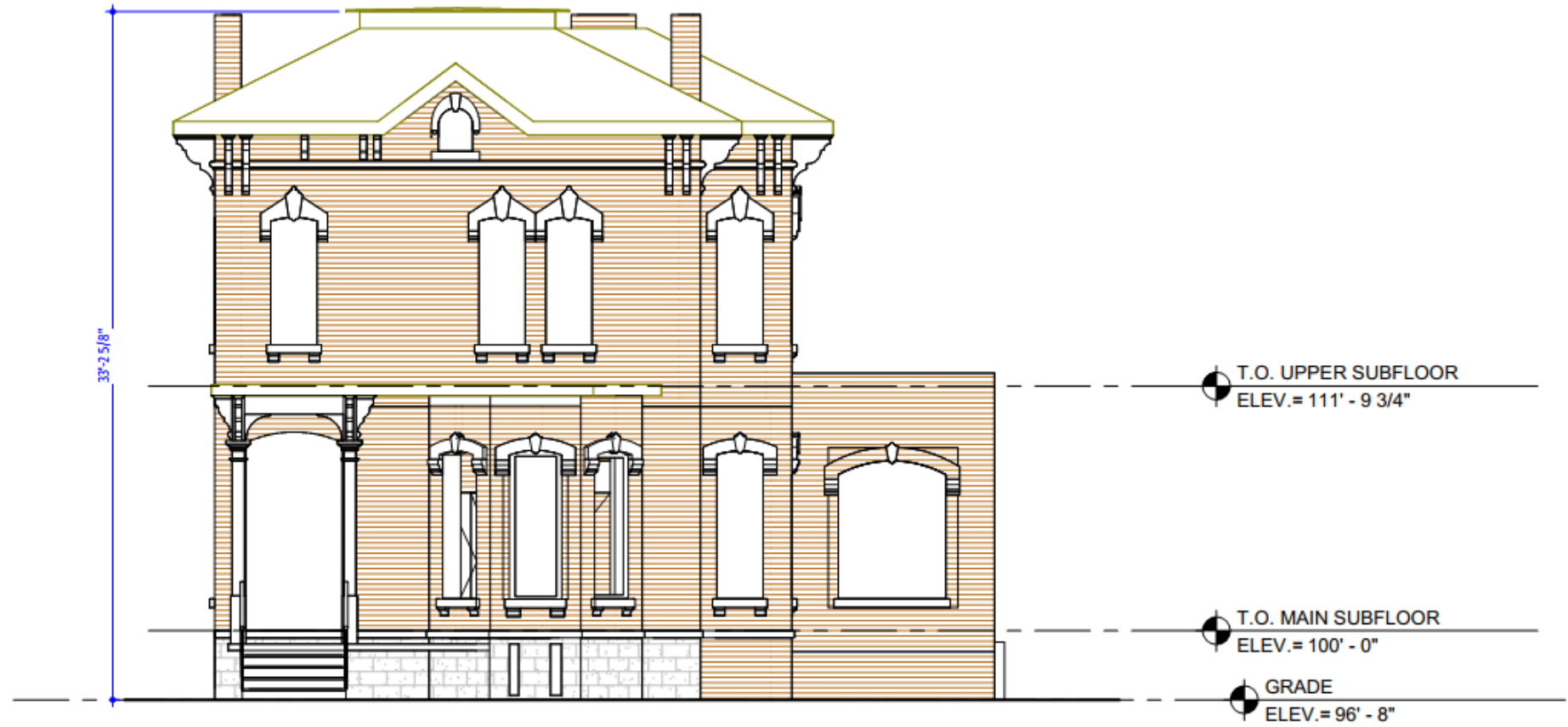

Project	Drawing	Scale	Project No.	Date	Issued For	By	Sheet Number
LINCOLN AVE.	EXISTING WEST ELEVATION	3/16" = 1'-0"	22007	09/09/24	Project Status	Author	HC3.2

MARK JOHNSON AND ASSOCIATES

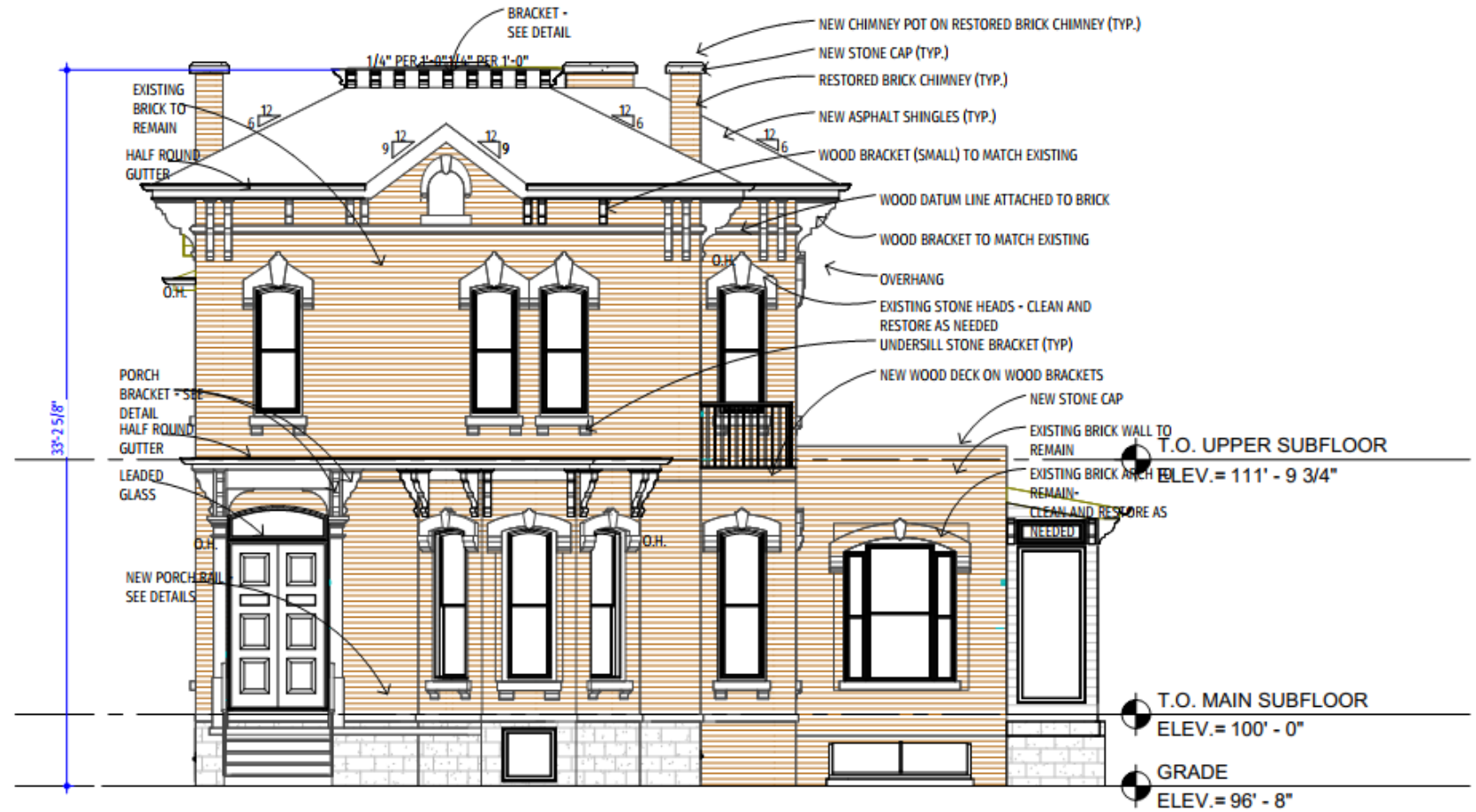

Project	Drawing	Scale	Project No.	Date	Issued For	By	Sheet Number
LINCOLN AVE.	PROPOSED WEST ELEVATION	3/16" = 1'-0"	22007	09/06/24	Project Status	Author	HC3.1

MARK JOHNSON AND ASSOCIATES



Project

LINCOLN AVE.

Drawing

PROPOSED WEST ELEVATION

Scale

3/16" = 1'-0"

Project No.

22007

Date

09/06/24

Issued For

Project Status

By

Author

Sheet Number

HC3.1

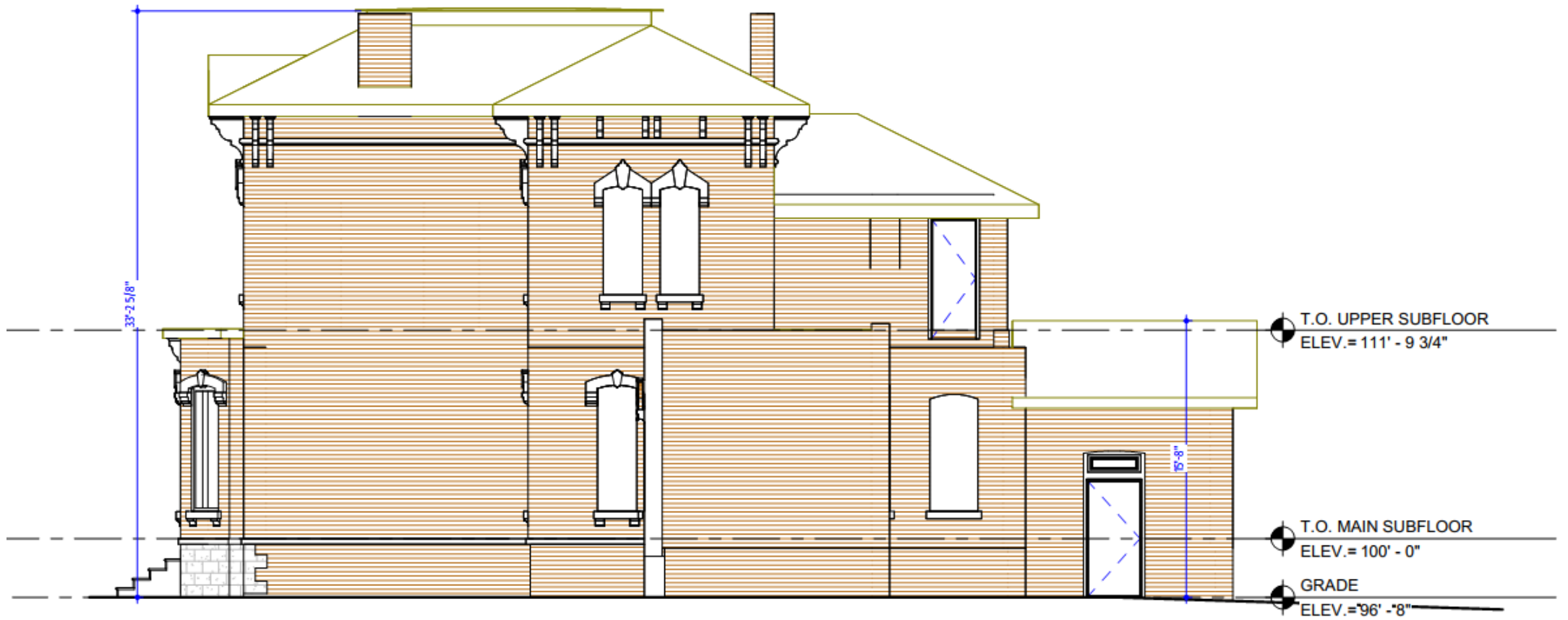

Project	Drawing	Scale	Project No.	Date	Issued For	By	Sheet Number
LINCOLN AVE.	EXISTING SOUTH ELEVATION	3/16" = 1'-0"	22007	09/09/24	Project Status	Author	HC3.4

MARK JOHNSON AND ASSOCIATES



Project	Drawing	Scale	Project No.	Date	Issued For	By	Sheet Number
LINCOLN AVE.	PROPOSED SOUTH ELEVATION	3/16" = 1'-0"	22007	09/06/24	Project Status	Author	HC3.3

MARK JOHNSON AND ASSOCIATES





Project	Drawing	Scale	Project No.	Date	Issued For	By	Sheet Number
LINCOLN AVE.	PROPOSED SOUTH ELEVATION	3/16" = 1'-0"	22007	09/06/24	Project Status	Author	HC3.3

MARK JOHNSON AND ASSOCIATES

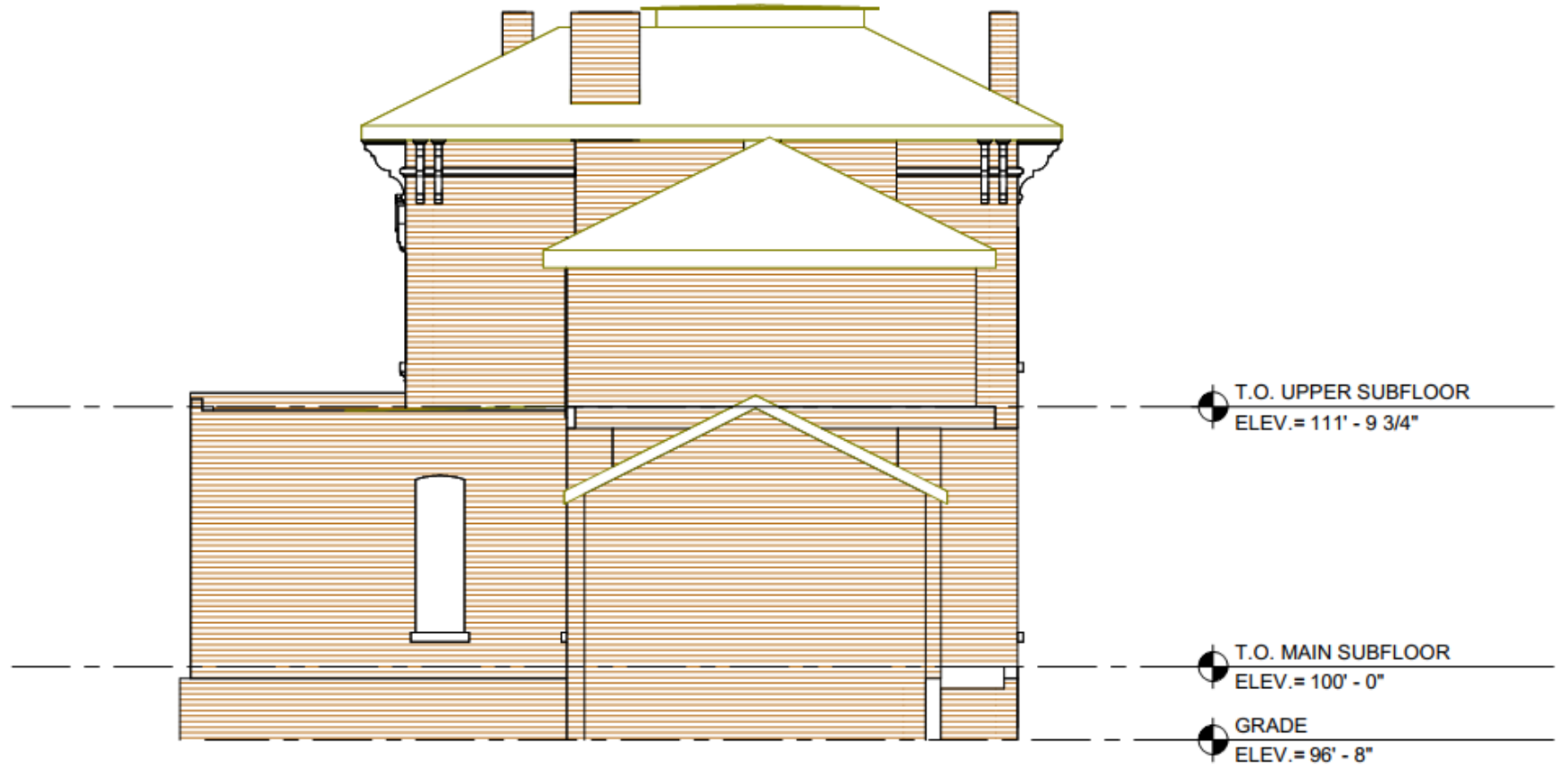

Project	Drawing	Scale	Project No.	Date	Issued For	By	Sheet Number
LINCOLN AVE.	EXISTING EAST ELEVATION	3/16" = 1'-0"	22007	09/09/24	Project Status	Author	HC3.6

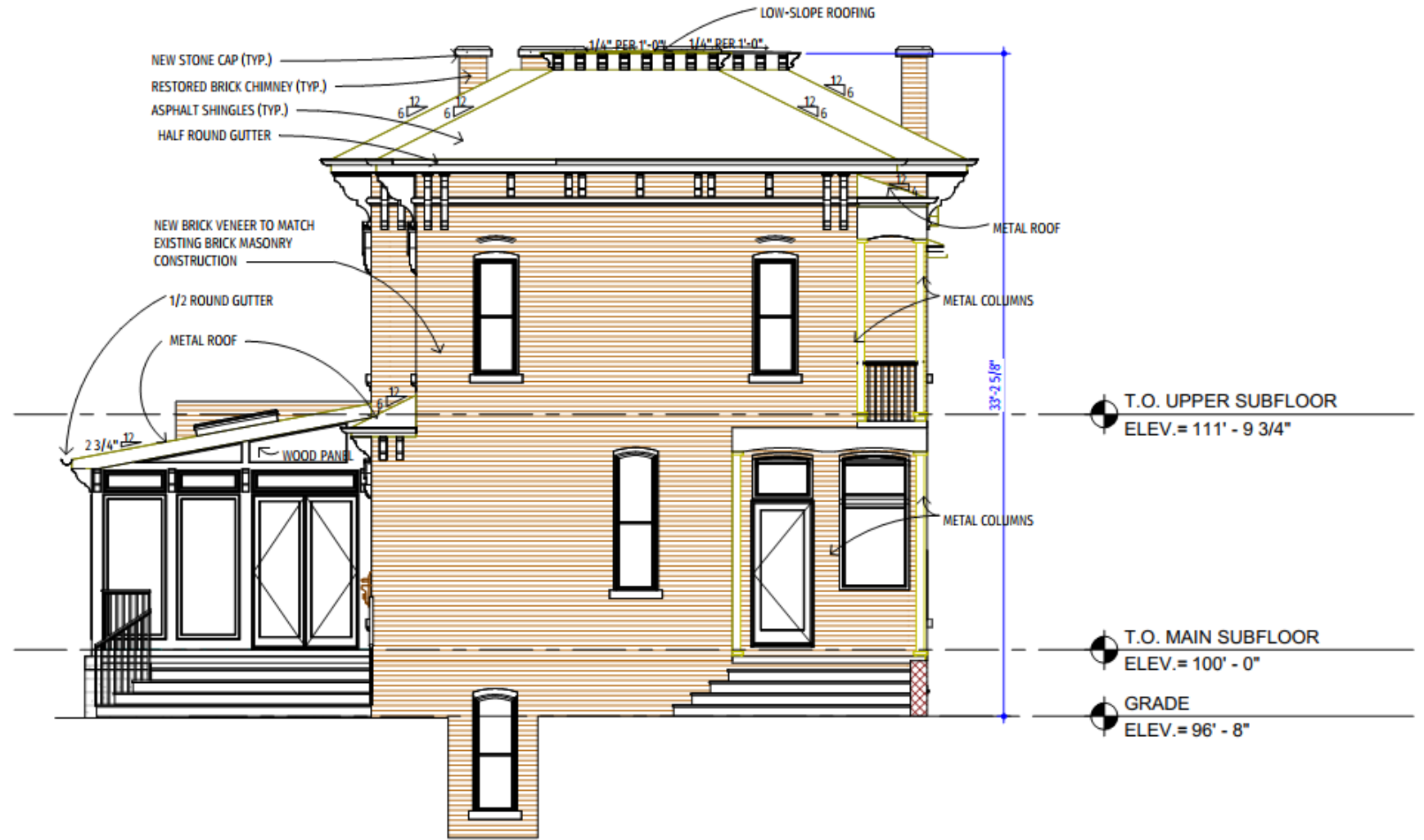

Project	Drawing	Scale	Project No.	Date	Issued For	By	Sheet Number
LINCOLN AVE.	PROPOSED EAST ELEVATION	3/16" = 1'-0"	2 2 0 7	09/06/24	Project Status	Author	HC3.5





Project

LINCOLN AVE.

Drawing

PROPOSED EAST ELEVATION

Scale

3/16" = 1'-0"

Project No.

22007

Date

09/06/24

Issued For

Project Status

By

Author

Sheet Number

HC3.5

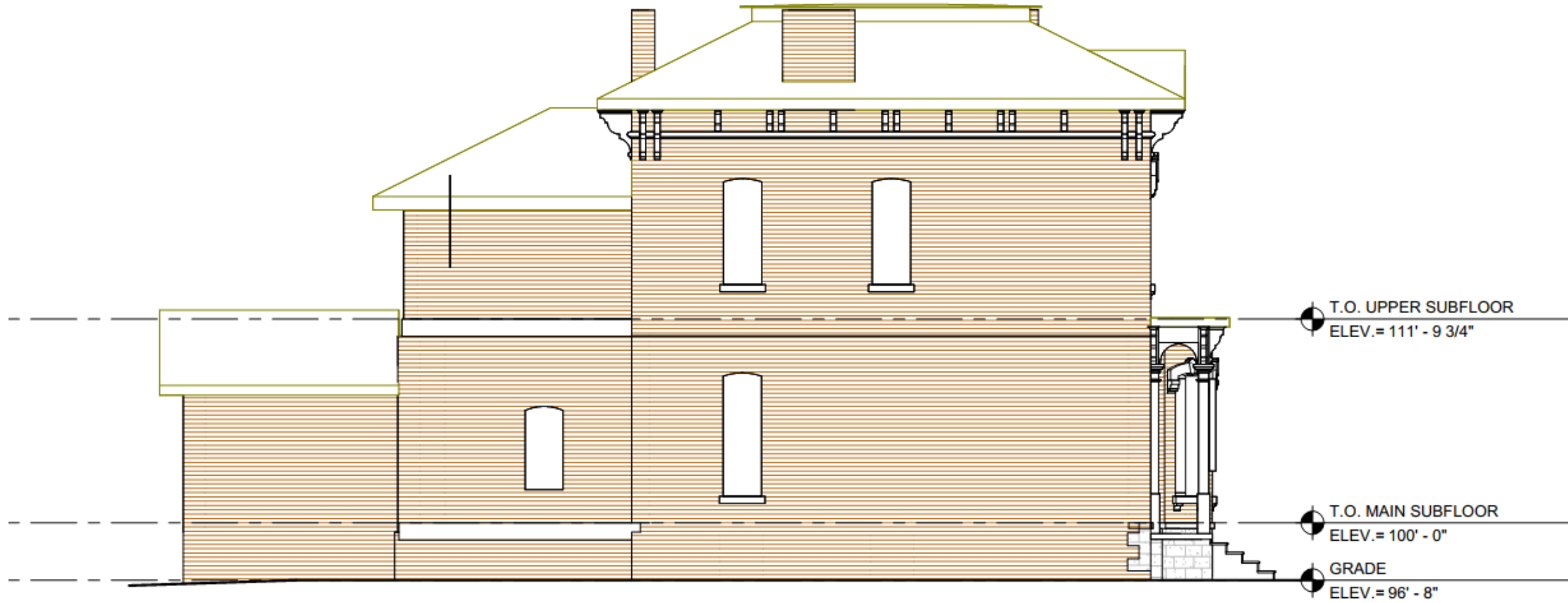

Project	Drawing	Scale	Project No.	Date	Issued For	By	Sheet Number
LINCOLN AVE.	EXISTING NORTH ELEVATION	3/16" = 1'-0"	22007	09/09/24	Project Status	Author	HC3.8

**MARK JOHNSON AND ASSOCIATES**

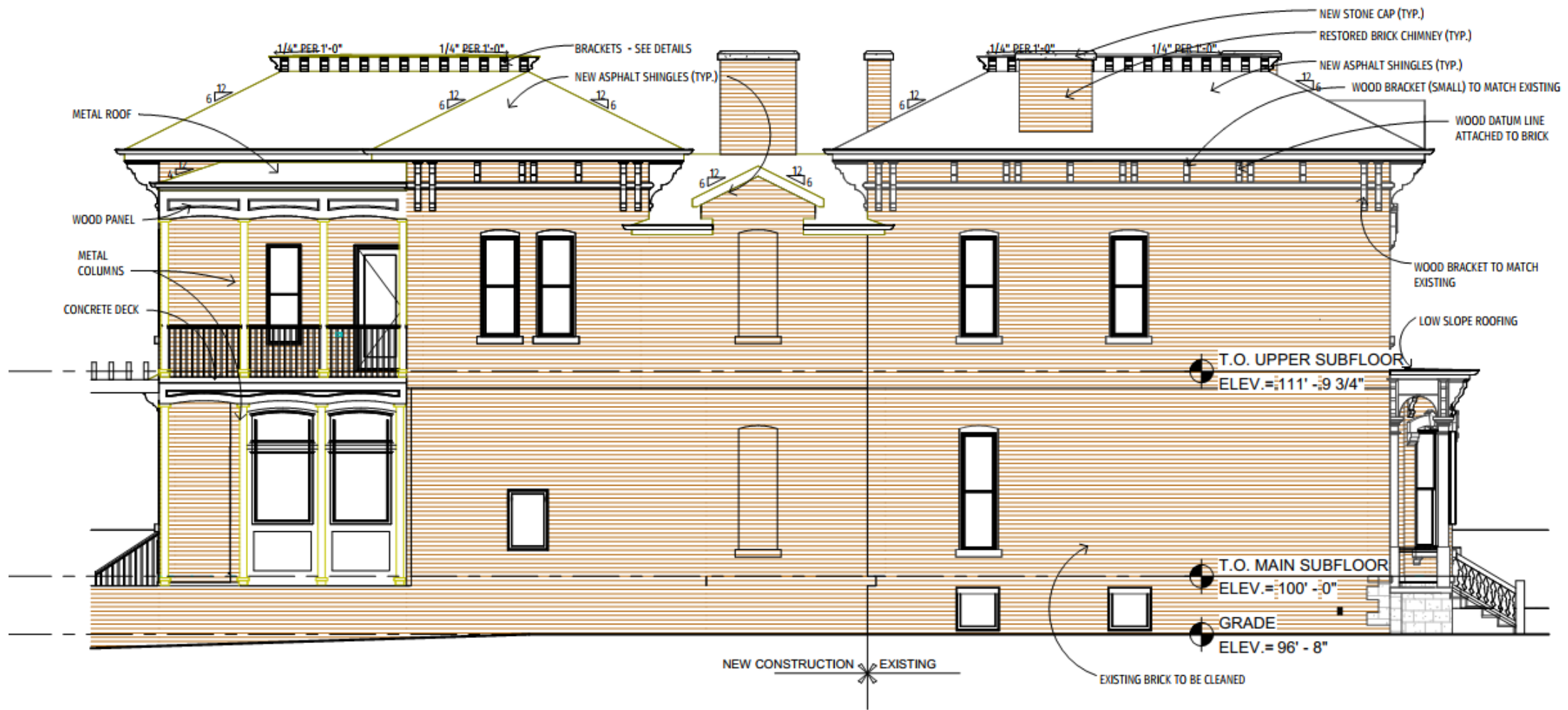

Project	Drawing	Scale	Project No.	Date	Issued For	By	Sheet Number
LINCOLN AVE.	PROPOSED NORTH ELEVATION	3/16" = 1'-0"	22007	09/06/24	Project Status	Author	HC3.7



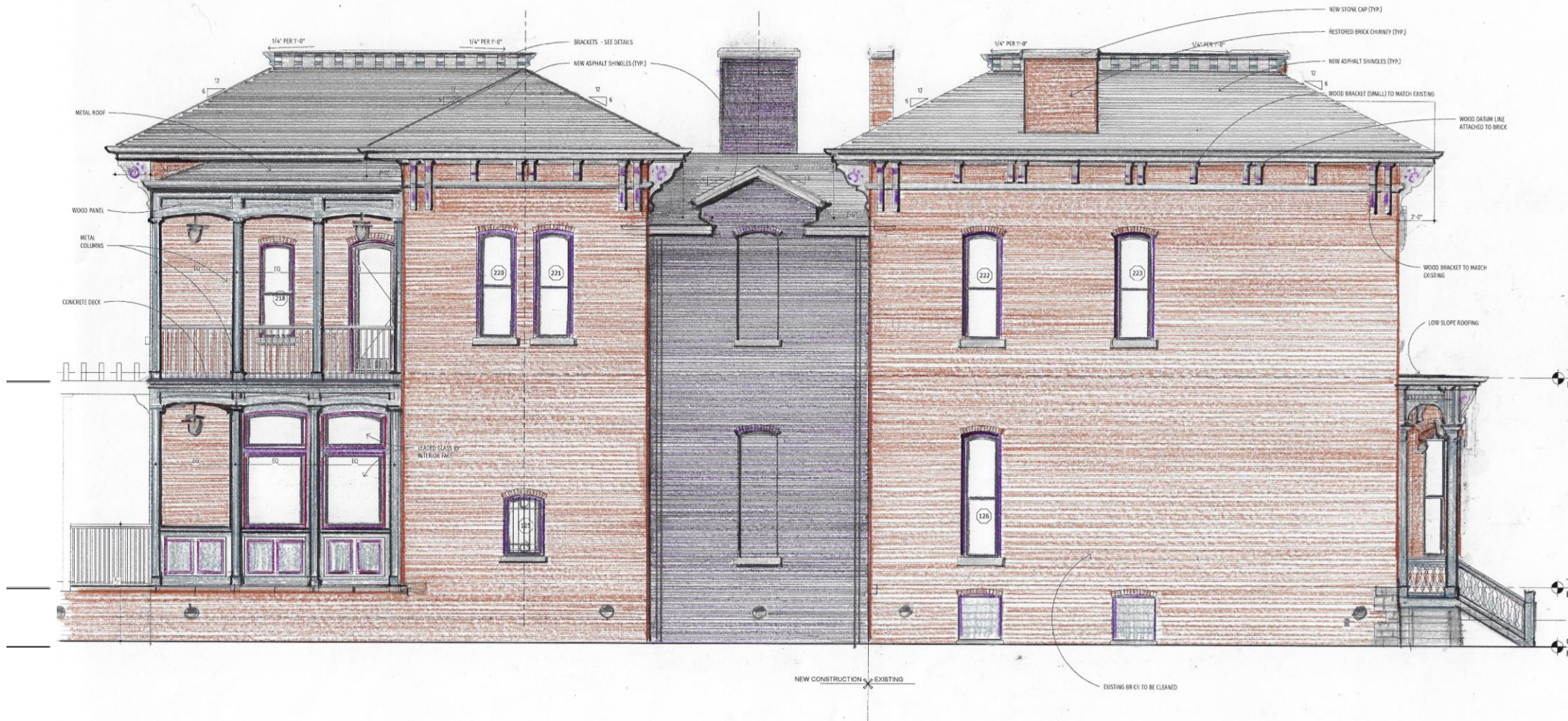

Project

LINCOLN AVE.

Drawing

PROPOSED NORTH ELEVATION

Scale

3/16" = 1'-0"

Project No.

22007

Date

09/06/24

Issued For

Project Status

By

Author

Sheet Number

HC3.7

MARK JOHNSON AND ASSOCIATES

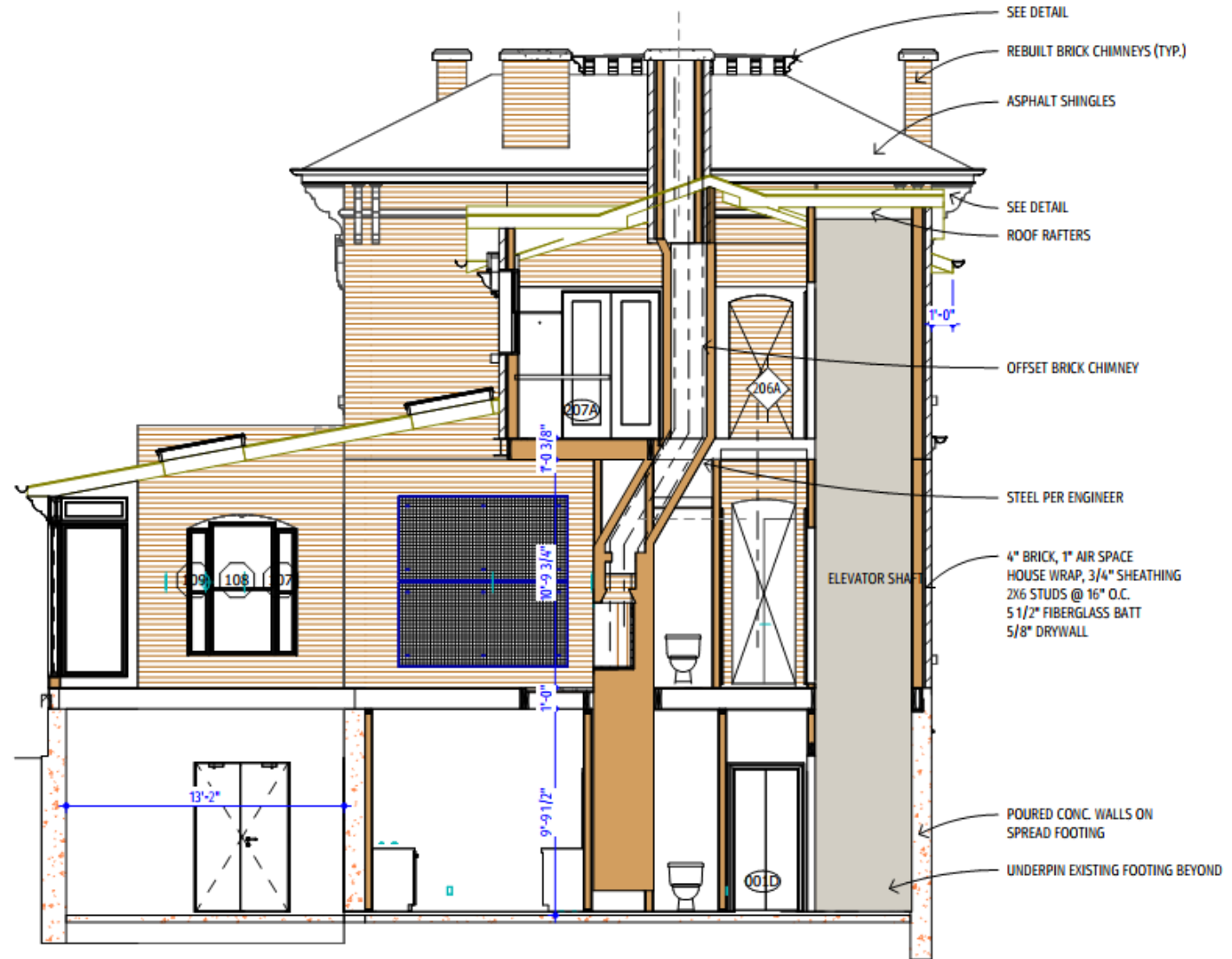

Project	Drawing	Scale	Project No.	Date	Issued For	By	Sheet Number
LINCOLN AVE.	BUILDING SECTIONS	3/16" = 1'-0"	22007	09/06/24	Project Status	Author	HC4.1



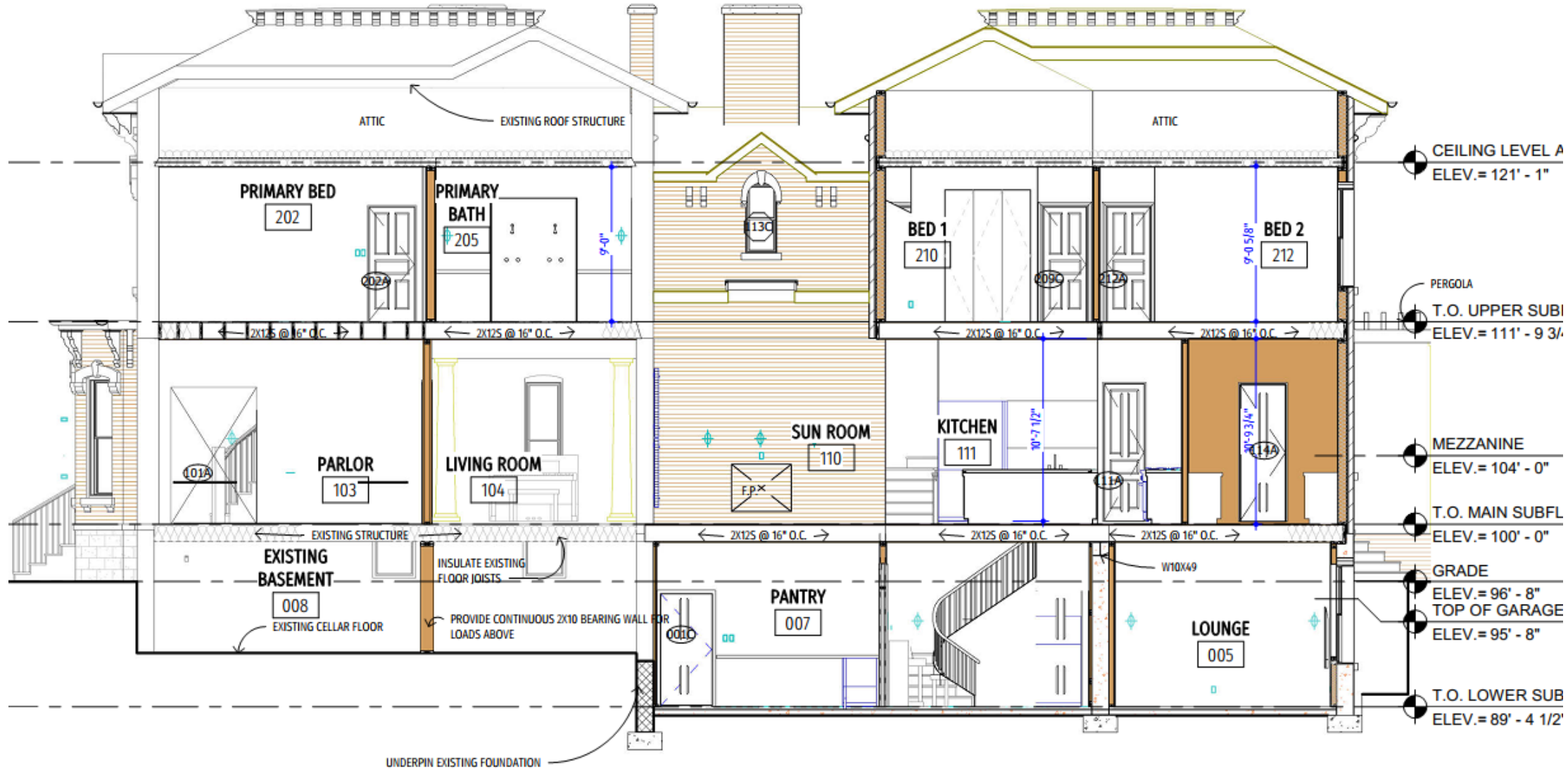

Project	Drawing	Scale	Project No.	Date	Issued For	By	Sheet Number
LINCOLN AVE.	BUILDING SECTIONS	3/16" = 1'-0"	22007	09/06/24	Project Status	Author	HC4.2

MARK JOHNSON AND ASSOCIATES



# Interior details

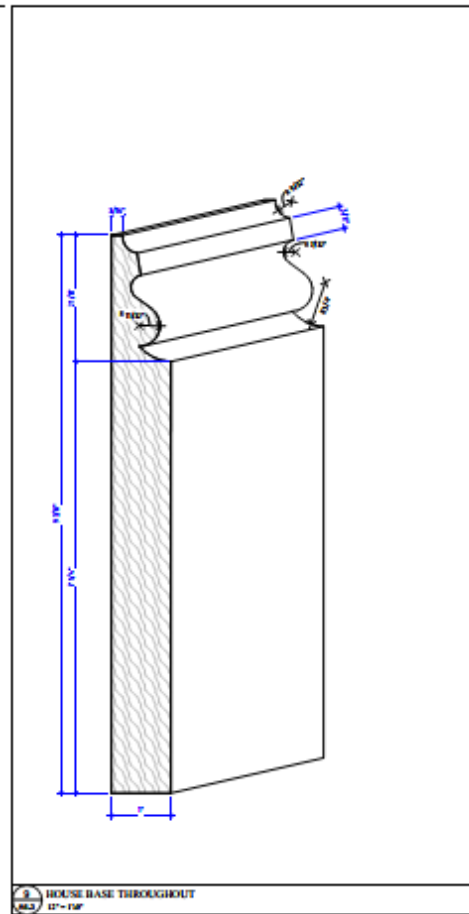

3 HOUSE BASE THROUGHOUT  
1/4" = 1'-0"

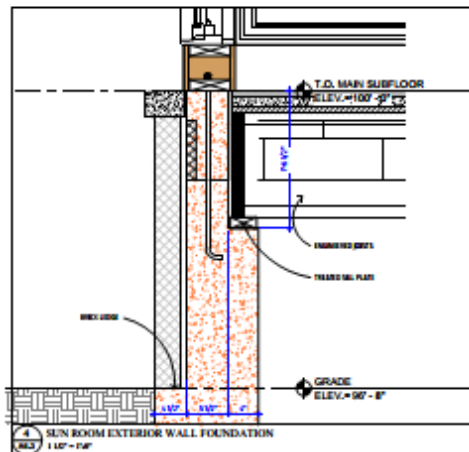

4 SUN ROOM EXTERIOR WALL FOUNDATION  
1/4" = 1'-0"

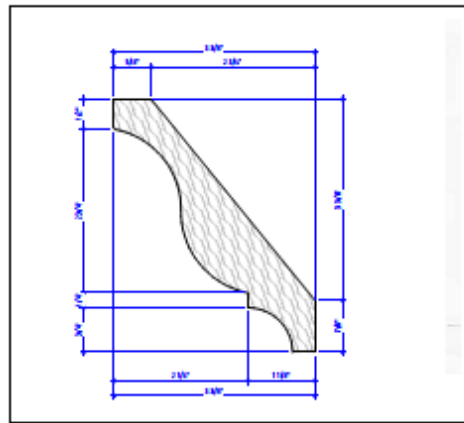

12 TYPICAL EXTERIOR CROWN  
1/4" = 1'-0"

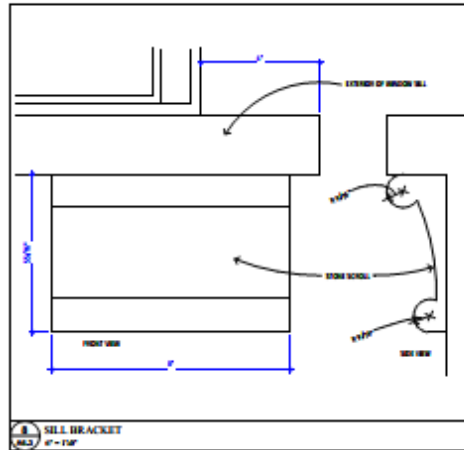

8 SILL BRACKET  
1/4" = 1'-0"

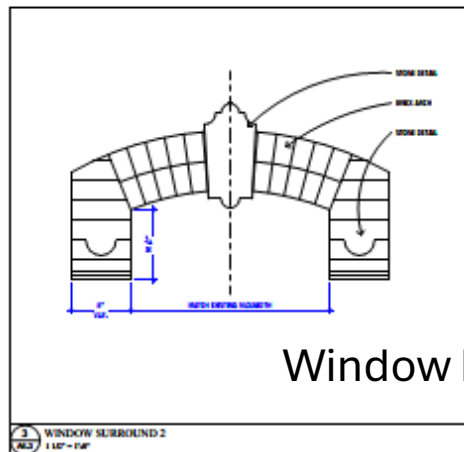

3 WINDOW SURROUND 2  
1/4" = 1'-0"

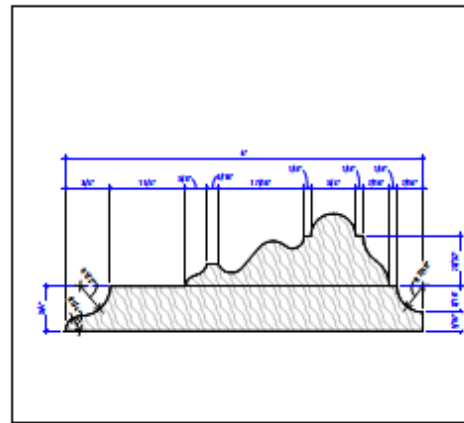

11 CASING  
1/4" = 1'-0"

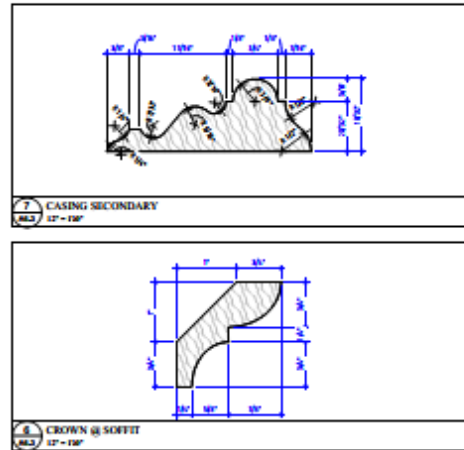

7 CASING SECONDARY  
1/4" = 1'-0"

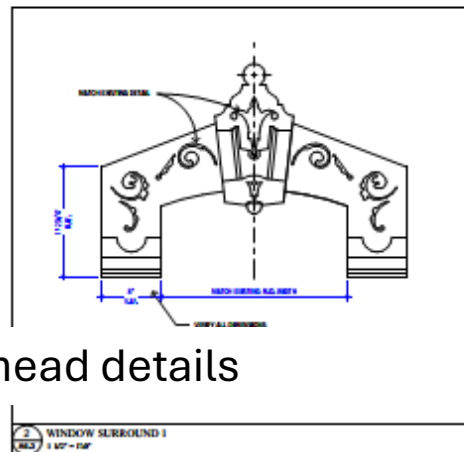

2 WINDOW SURROUND 1  
1/4" = 1'-0"

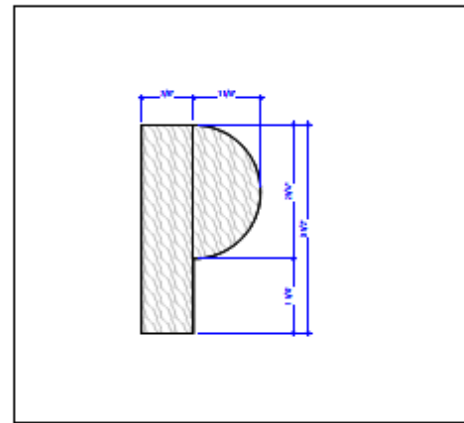

10 DATUM @ UPPER WALL  
1/4" = 1'-0"

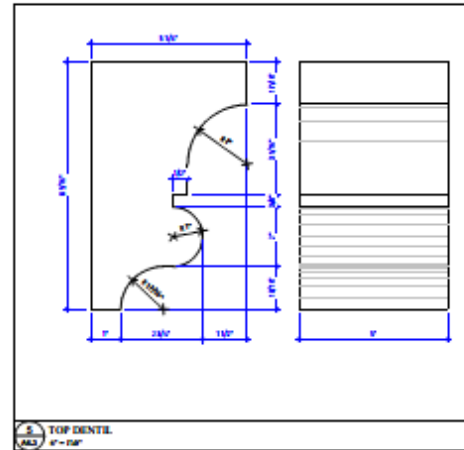

5 TOP DENTIL  
1/4" = 1'-0"

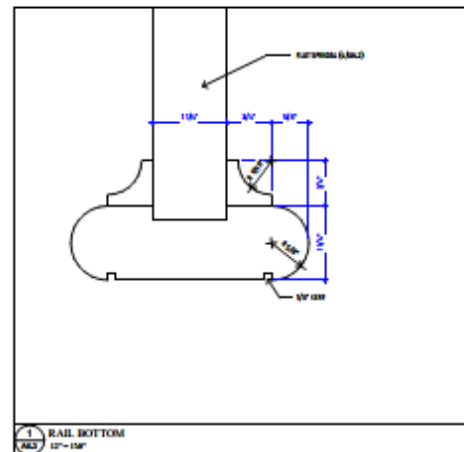

1 RAIL BOTTOM  
1/4" = 1'-0"

# Window head details

Mark Johnson and Associates  
1000 Woodward Ave., Suite 100  
Detroit, MI 48208  
Phone (313) 963-8888  
Fax (313) 963-8889

PROJECT NO. 22007  
DATE: 10/15/18  
REVISIONS:  
PROJECT NUMBER: 22007  
SHEET TITLE: EXTERIOR DETAILS  
SHEET NUMBER: A6.3  
30 NOT SCALE DRAWING

LINCOLN AVE.  
REMODEL  
3644 LINCOLN AVE.  
DETROIT, MICHIGAN 48208



# Material samples – Main original and Addition

- Window Mock-up
- Brick Samples
  - Existing Brick A
  - New Brick B
  - Transitional Brick C
  - Stone D
- Paint colors
- Front door
- Roofing

Samples will be brought to Meeting on Oct. 9th

# Window Mock-Up





# Brick Samples





# Existing Roof



# Proposed Roof

ART-LOC  
STORMPROOF HIGH IMPACT SHINGLES



Earth Blend

-OR-

ART-LOC  
STORMPROOF HIGH IMPACT SHINGLES

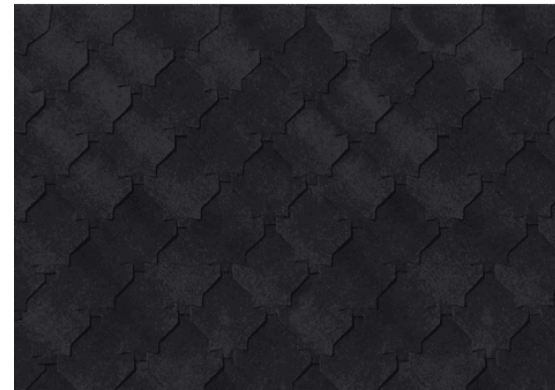

Charcoal Black

Sherriff Goslin Art-Loc shingles

# Metal roof

Color: Burnished slate

Location:  
Sunroom Roof



Finishes You've Never Seen Before\*

## WESTERN STATES METAL ROOFING

(877) 787-5467 | WESTERNSTATESMETALROOFING.COM

### COLOR SELECTION GUIDE STANDARD COLORS (PVDF)

Colors represented on this chart may not exactly match actual material.  
All colors should be verified using actual metal samples.



**STANDARD COLORS:**

Regal Blue	Royal Blue	Slate Blue	Regal Red	Colonial Red	Terra Cotta	Classic Green
Matte Black	Dark Bronze	Medium Bronze	Mansard Brown	Burnished Slate	Charcoal Gray	Gun Metal Gray
Slate Gray	Dolphin Gray	Dove Gray	Ash Gray	Desert Tan	Sandstone	Almond



# Front Door

Existing door from 1979 Photo A

Proposed Door B

Optional door C

- Leaded Glass Panels
- Leaded Glass Transom

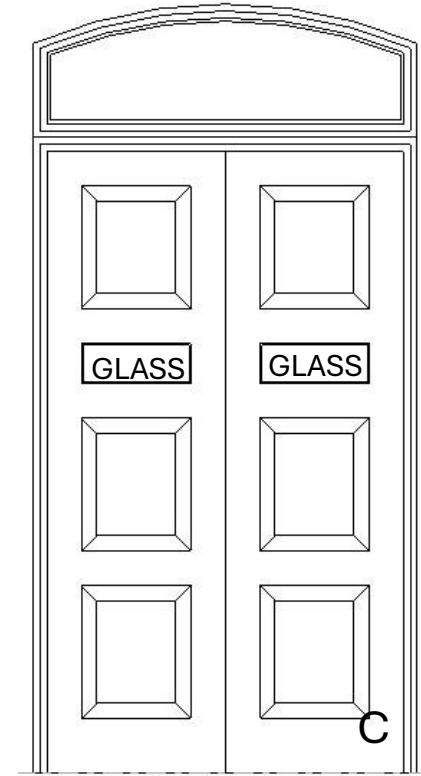
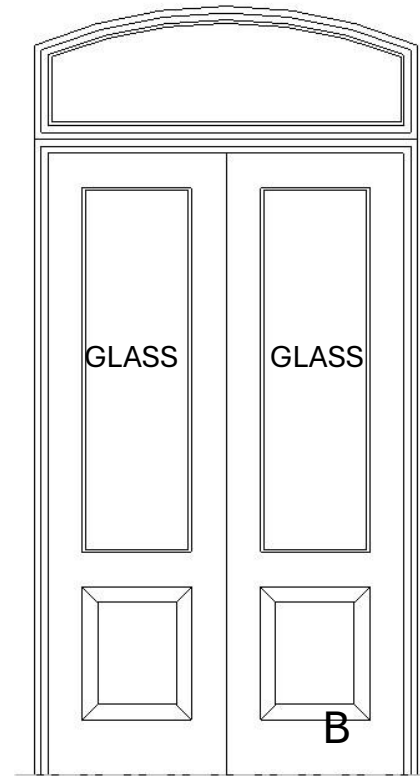

# Detached accessory building

---

The garage located at 3644 Lincoln is one-story in height and was erected from cinder blocks ca.1920. The building is rectangular in plan and features a gabled roof. It is likely that the current wood drop siding was installed at the front and wall and gable end in the 1930-1940. The current garage door is a metal and looks like it was more recently installed. The people doors on the west and south side have been removed and are not located on the site. The existing windows are steel and contain no glass. The structure is not stable.

The proposed detached accessory building will be the same depth as the existing garage (24'-0") and twice the existing width (48'-0"). We are proposing to incorporate the existing cinder block walls of the garage into the first level walls of the new carriage house. The upper level of the accessory building will have a low roofline to keep the profile of the building down. This will create clipped ceiling in the interior.

Further South at 3523 Gibson is the inspiration for the proposed Accessory building and is pictured here.

We are proposing to mimic some of the details on this building such as the 'swoop' where the siding meets the masonry. Because our roof is lower than the inspiration, we will have dormers to create headspace in the loft.





# Existing Garage



East elevation



Carpentry Detail



S-W corner



S-W corner



Cinder Block Detail



# Proposed color palette

## Accessory Building



- **Cinder Block - Reclaimed**
- South and East First Floor Facades



- **Cinder Block – New to match existing**
- West and North First Floor Facades



- **B:12 Grayish Green MS: 10G 4/2**
- Second Floor Wood Siding and dormer sides
- Gutters and Downspouts



- **A9: Moderate Reddish Brown: 7.5R 3/6**
- String Course below siding
- Dormer Cornice
- 2<sup>nd</sup> Floor Cornice



- **Taupe, Light: SW7643 Pussywillow**
- All Window frames, casing
- All Garage Doors
- All South and West Entry Doors

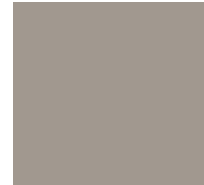

- **Taupe, Dark: SW7642 Pavestone**
- All Window Sashes
- Garage Door, Frames, Casing
- South and West Entry Doors, Frames, Casing



- **A9: Moderate Reddish Brown: 7.5R 3/6**
- Coach Lanterns

# Proposed Garage Door

- Carriage House Door:
- <https://www.carriagedoor.com/savannah/>
- Wood collection
- Painted wood
- Insulated
- Savannah
- 9'-0" x 9'-0"



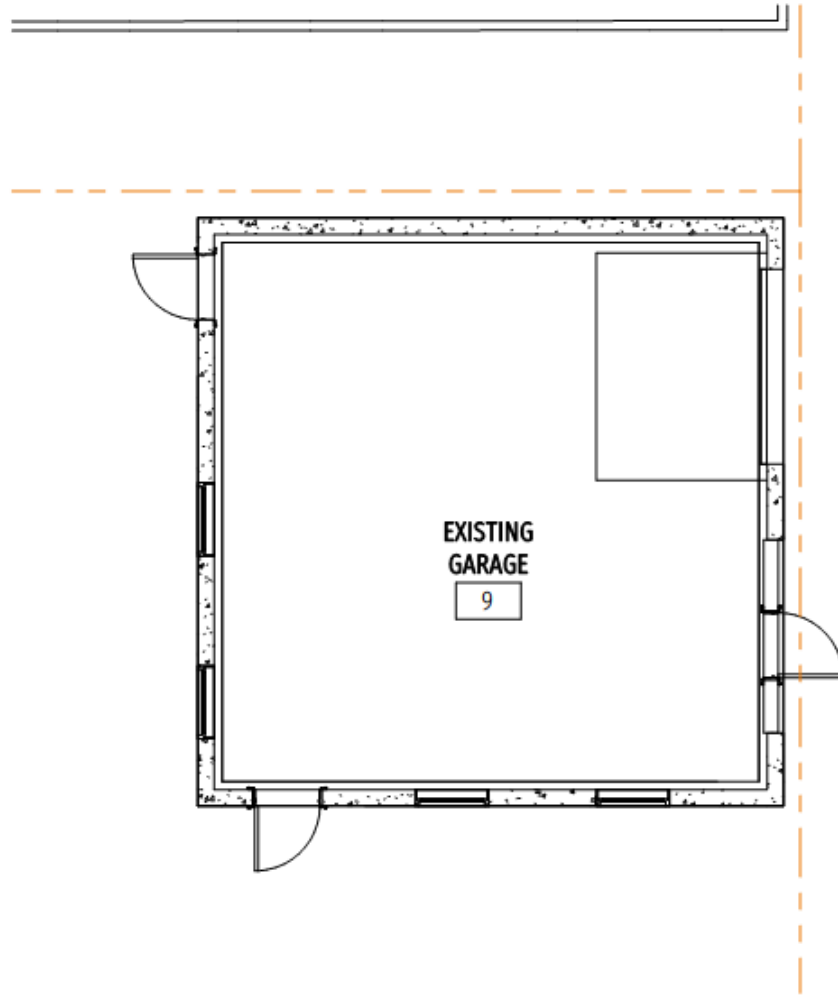

Project	Drawing	Scale	Project No.	Date	Issued For	By	Sheet Number
LINCOLN AVE.	EXISTING MAIN LEVEL GARAGE PLAN	3/16" = 1'-0"	2 2 0 0 7	09/09/24	Project Status	Author	HC2.6



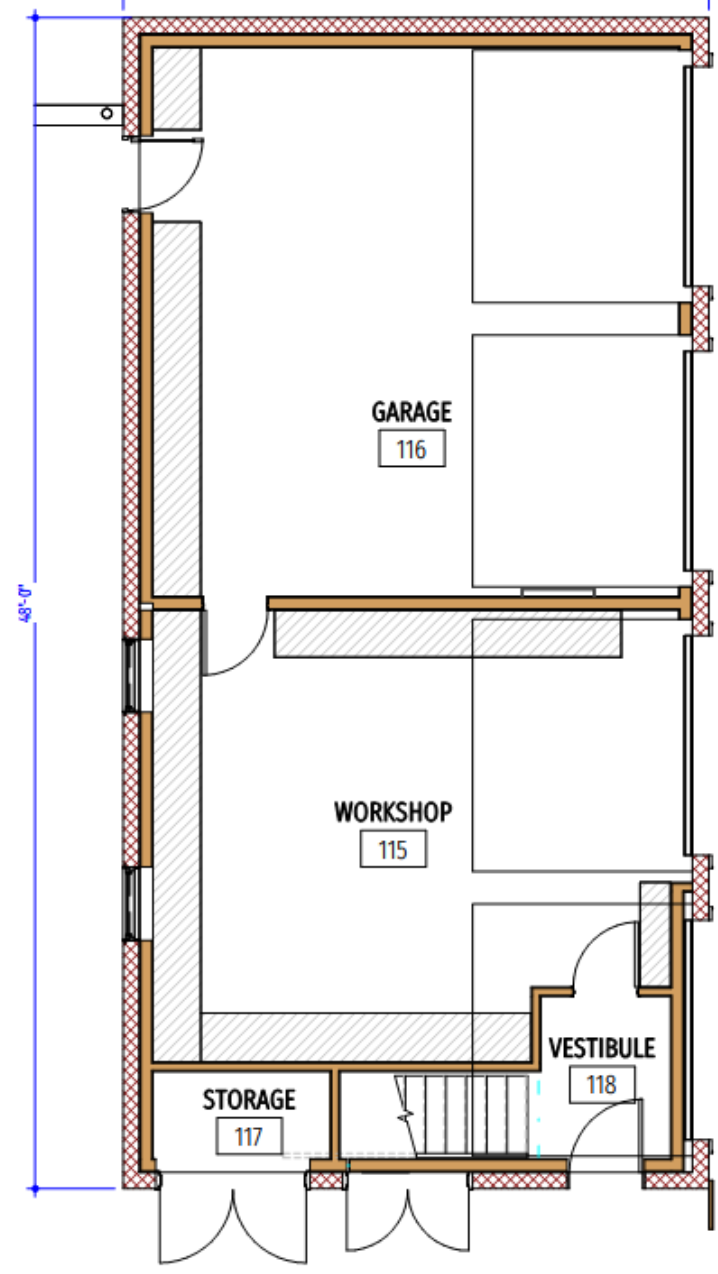

Project	Drawing	Scale	Project No.	Date	Issued For	By	Sheet Number
LINCOLN AVE.	PROPOSED MAIN GARAGE LEVEL	3/16" = 1'-0"	2 2 0 7	09/06/24	Project Status	Author	HC2.5

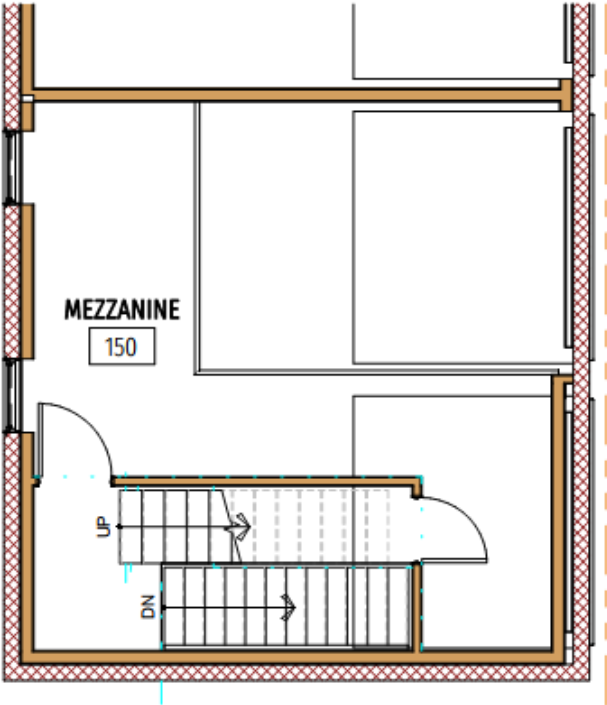

Project

LINCOLN AVE.

Drawing

MEZZANINE LEVEL @ GARAGE

Scale

3/16" = 1'-0"

Project No.

2 2 0 0 7

Date

09/06/24

Issued For

Project Status

By

Author

Sheet Number

HC2.10

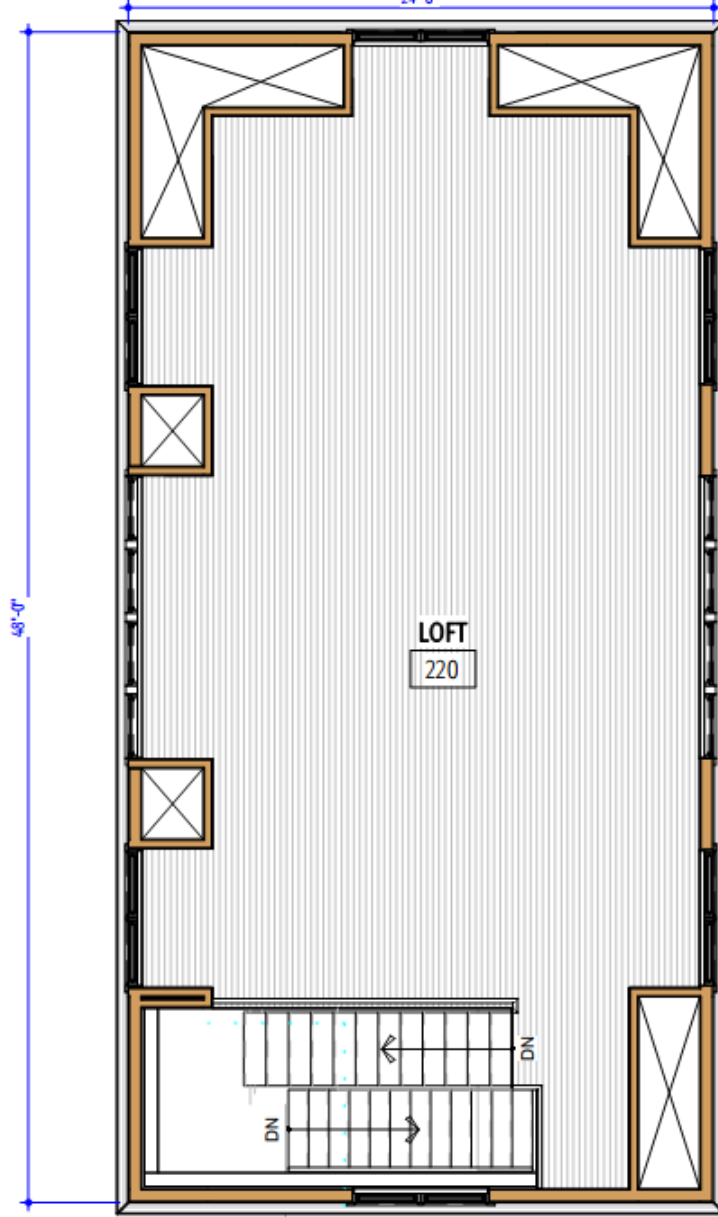

Project	Drawing	Scale	Project No.	Date	Issued For	By	Sheet Number
LINCOLN AVE.	PROPOSED UPPER LEVEL GARAGE PLAN	3/16" = 1'-0"	22007	09/06/24	Project Status	Author	HC2.9

**MARK JOHNSON AND ASSOCIATES**



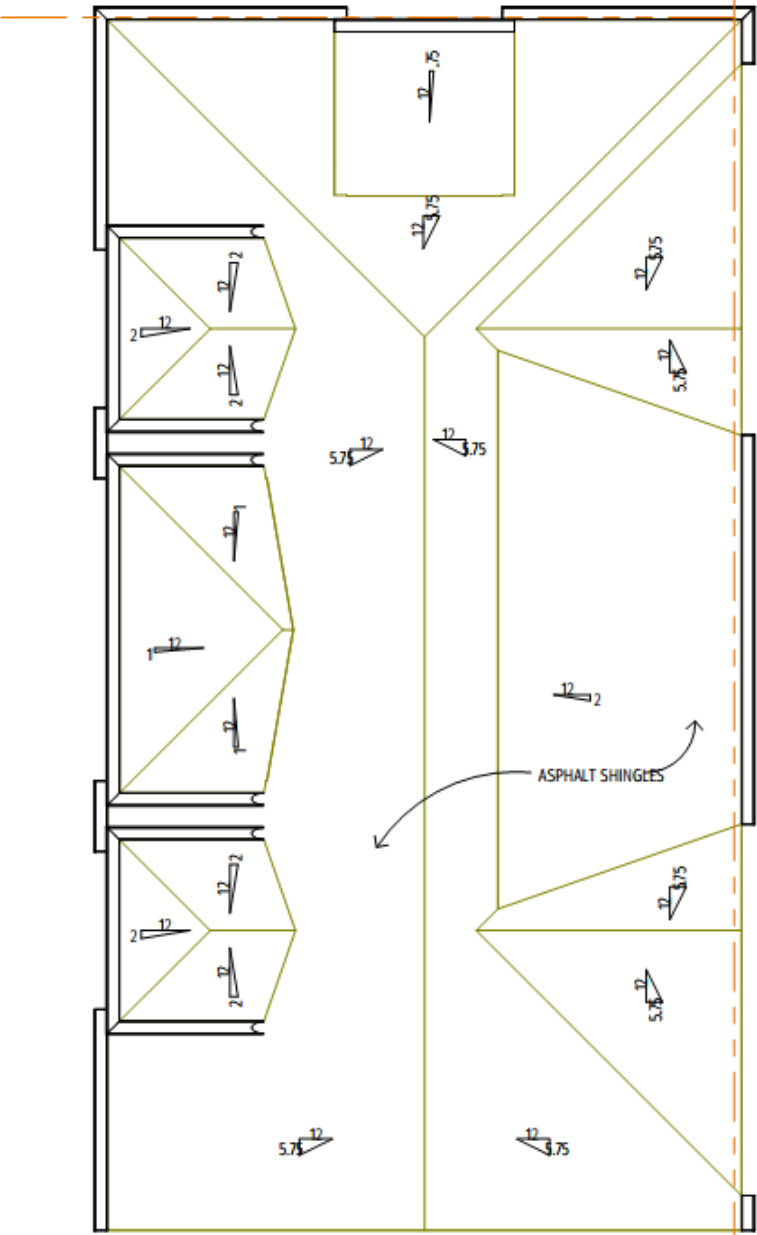

Project

LINCOLN AVE.

Drawing

PROPOSED GARAGE ROOF PLAN

Scale

3/16" = 1'-0"

Project No.

2 2 0 7

Date

09/06/24

Issued For

Project Status

By

Author

Sheet Number

HC2.13

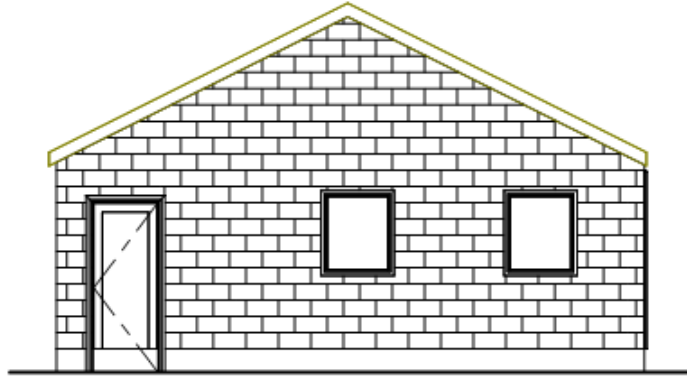

Project	Drawing	Scale	Project No.	Date	Issued For	By	Sheet Number
LINCOLN AVE.	EXISTING GARAGE WEST ELEVATION	3/16" = 1'-0"	2 2 0 0 7	09/09/24	Project Status	Author	HC3.10

**MARK JOHNSON AND ASSOCIATES**



Project	Drawing	Scale	Project No.	Date	Issued For	By	Sheet Number
LINCOLN AVE.	PROPOSED GARAGE WEST ELEVATION	3/16" = 1'-0"	2 2 0 0 7	09/06/24	Project Status	Author	HC3.9

MARK JOHNSON AND ASSOCIATES





Project LINCOLN AVE.	Drawing PROPOSED GARAGE WEST ELEVATION	Scale 3/16" = 1'-0"	Project No. 22007	Date 09/06/24	Issued For Project Status	By Author	Sheet Number HC3.9
-------------------------	---	------------------------	----------------------	------------------	------------------------------	--------------	-----------------------

MARK JOHNSON AND ASSOCIATES

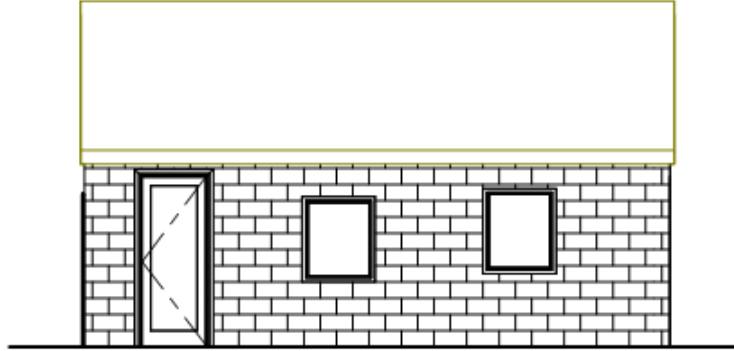

Project	Drawing	Scale	Project No.	Date	Issued For	By	Sheet Number
LINCOLN AVE.	EXISTING GARAGE SOUTH ELEVATION	3/16" = 1'-0"	2 2 0 0 7	09/06/24	Project Status	Author	HC3.12

**MARK JOHNSON AND ASSOCIATES**

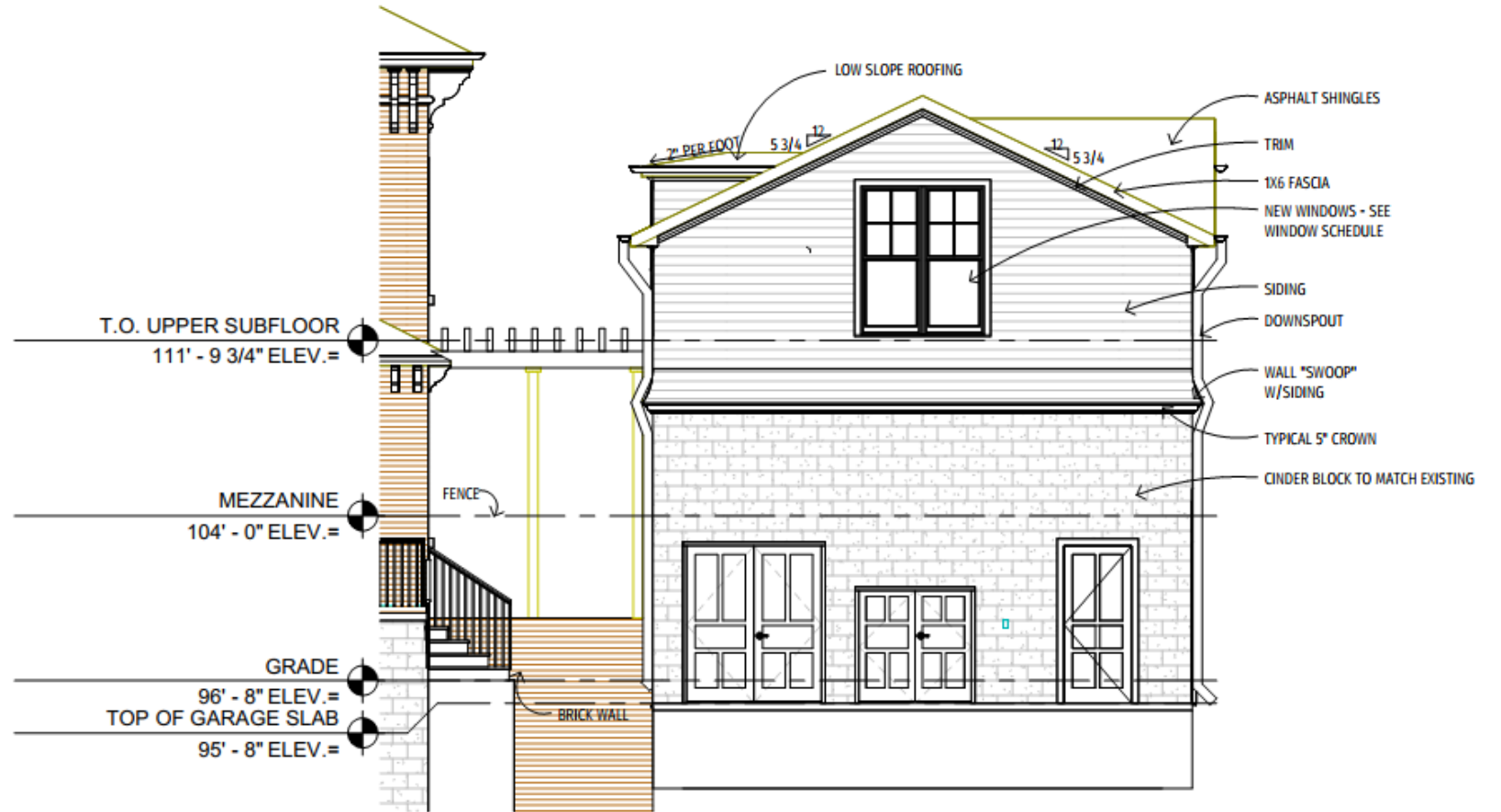

Project	Drawing	Scale	Project No.	Date	Issued For	By	Sheet Number
LINCOLN AVE.	PROPOSED GARAGE SOUTH ELEVATION	3/16" = 1'-0"	2 2 0 0 7	09/06/24	Project Status	Author	HC3.11



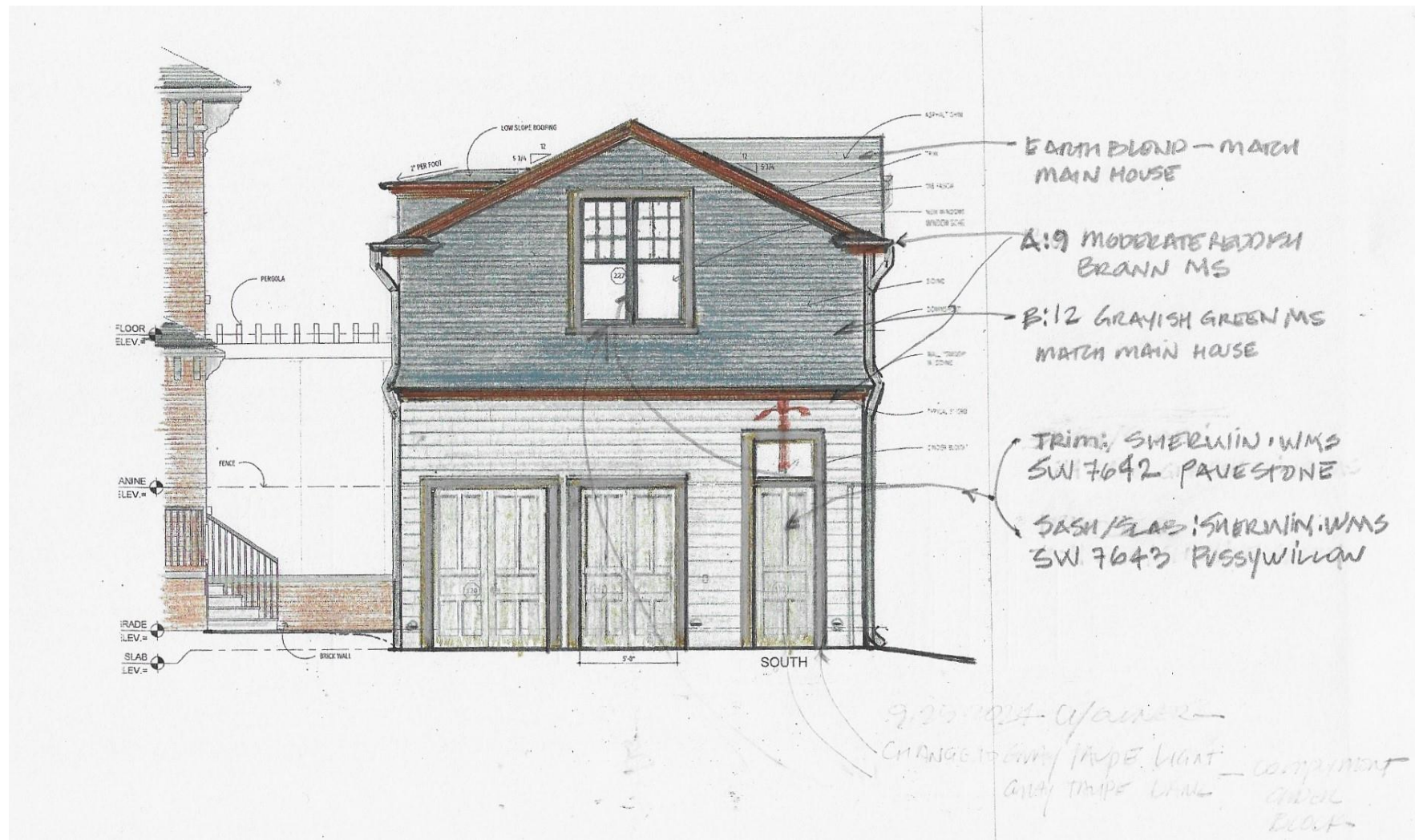

Project	Drawing	Scale	Project No.	Date	Issued For	By	Sheet Number
LINCOLN AVE.	PROPOSED GARAGE SOUTH ELEVATION	3/16" = 1'-0"	22007	09/06/24	Project Status	Author	HC3.11



Project	Drawing	Scale	Project No.	Date	Issued For	By	Sheet Number
LINCOLN AVE.	EXISTING GARAGE EAST ELEVATION	3/16" = 1'-0"	2 2 0 0 7	09/06/24	Project Status	Author	HC3.14

**MARK JOHNSON AND ASSOCIATES**



EAST

Project	Drawing	Scale	Project No.	Date	Issued For	By	Sheet Number
LINCOLN AVE.	PROPOSED GARAGE EAST ELEVATION	3/16" = 1'-0"	2 2 0 7	09/06/24	Project Status	Author	HC3.13

MARK JOHNSON AND ASSOCIATES





Project	Drawing	Scale	Project No.	Date	Issued For	By	Sheet Number
LINCOLN AVE.	PROPOSED GARAGE EAST ELEVATION	3/16" = 1'-0"	22007	09/06/24	Project Status	Author	HC3.13

MARK JOHNSON AND ASSOCIATES

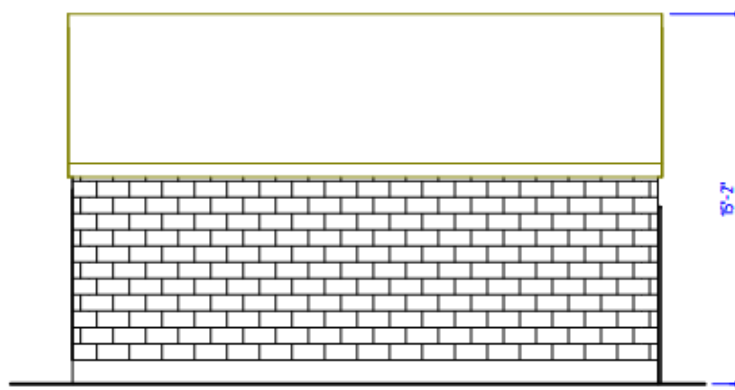

Project	Drawing	Scale	Project No.	Date	Issued For	By	Sheet Number
LINCOLN AVE.	EXISTING GARAGE NORTH ELEVATION	3/16" = 1'-0"	2 2 0 0 7	09/06/24	Project Status	Author	HC3.16

**MARK JOHNSON AND ASSOCIATES**

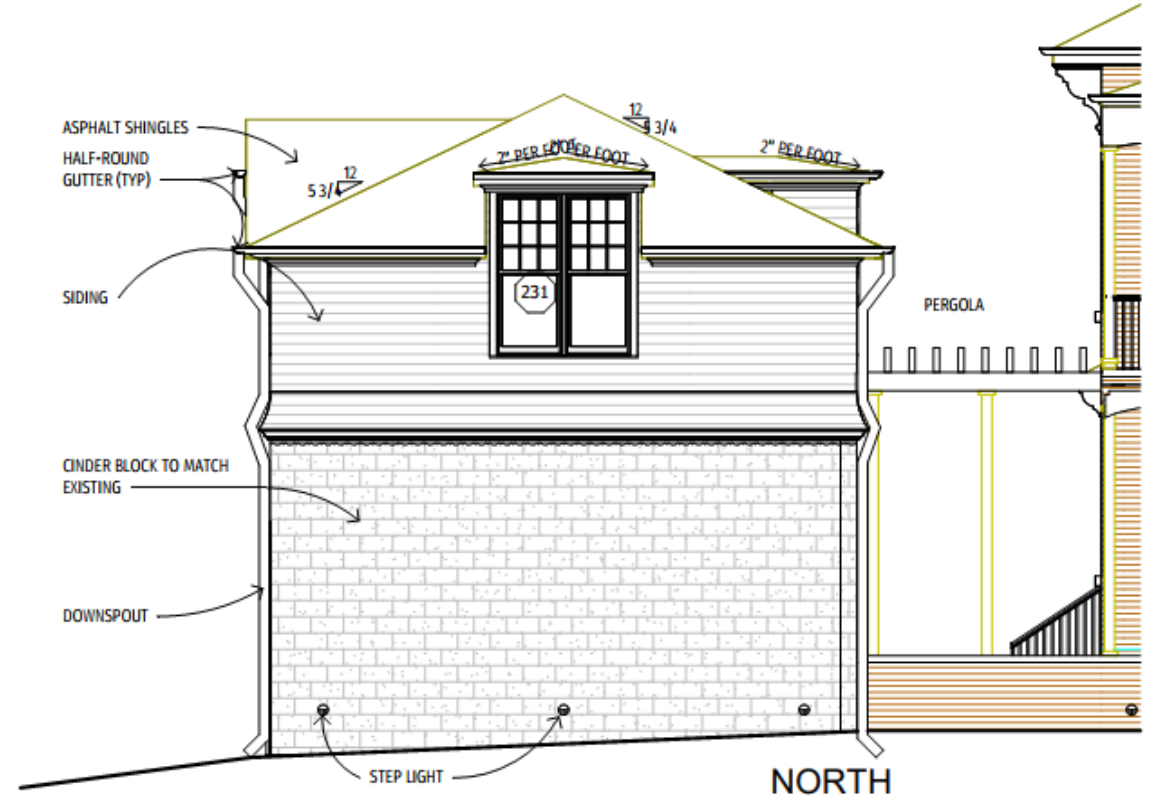

Project	Drawing	Scale	Project No.	Date	Issued For	By	Sheet Number
LINCOLN AVE.	PROPOSED GARAGE NORTH ELEVATION	3/16" = 1'-0"	2 2 0 0 7	09/06/24	Project Status	Author	HC3.15

MARK JOHNSON AND ASSOCIATES





Project

LINCOLN AVE.

Drawing

PROPOSED GARAGE NORTH ELEVATION

Scale

3/16" = 1'-0"

Project No.

22007

Date

09/06/24

Issued For

Project Status

By

Author

Sheet Number

HC3.15

# Porch Reconstruction

- The Porch will be reconstructed to the original standards and details.
- The original colors are not known.
- The existing porch boards will be replaced – they are restored, and the ends are rotted out.
- The porch columns will be restored, and the lower trim will be cleaned and evaluated for re-use.
- The non-functioning handrail will be replaced with a period appropriate handrail.
- The roof structure will be evaluated for safety and possibly replaced – keeping the profile and thickness of the existing roof.
- The Porch details at the cornice will be cleaned and re-installed. Where the woodwork is not able to be saved there will be a replica piece in the same material as the original.
- Replacement of any materials will only occur in the event the item in question cannot be cleaned and restored. Fire has affected a large portion of the detail on the house, but every effort will be made to restore the items that are able to be restored. All items being replaced will be the same material of the piece it is replacing.





Existing  
Column  
Capital

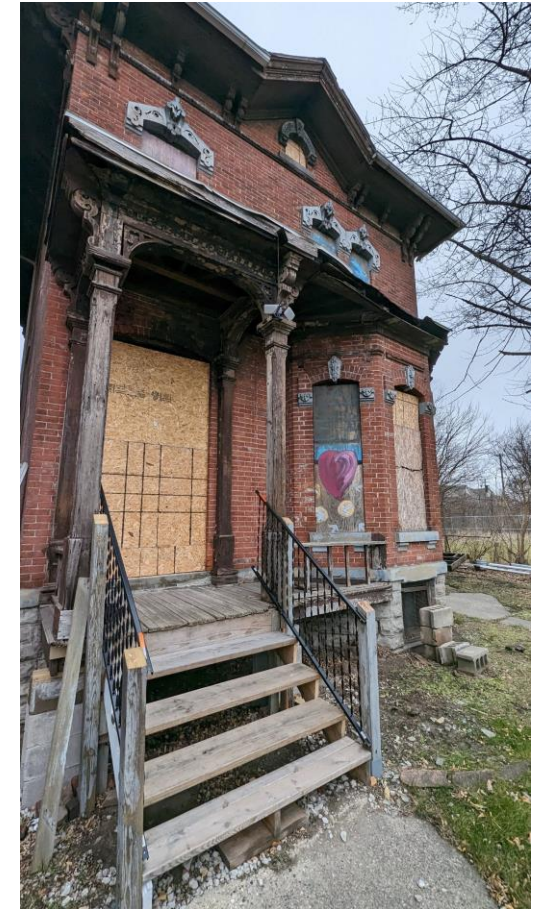

Existing Porch





Existing Porch  
Conditions