

September 21, 2022

NOTICE OF DENIAL

Brooke Schwartz & Steve Edelman
768 Bird Avenue
Birmingham MI 48009

**RE: Application Number 22-8012; 1556 Bagley; Corktown Historic District
Project Scope: Rehabilitate Dwelling**

Dear Applicant,

At the Regular Meeting that was held on September 14, 2022, the Detroit Historic District Commission (“DHDC”) reviewed the above-referenced application. Pursuant to Section 5(1) and 9(1) of the Michigan Local Historic District Act, as amended, being MCL 399.205 (1), MCL 399.209 (9) and Sections 21-2-78 and 21-2-80 of the 2019 Detroit City Code; the DHDC hereby issues a Denial for the following work, effective on September 21, 2022, as it will be inappropriate according to the Secretary of Interior’s Standards for Rehabilitation and the district’s Elements of Design:

Installation of Hardie board cedar lap siding (raised grain), and replacement of single opening wood/glass door at first floor rear elevation per the submitted documents, drawings, photographs, and product data.

Excepting the following items from denial:

- ***Repair and paint white existing front porch, replace windows on the sides and rear of the house (and single opening front elevation window), reduce size of first floor rear window, remove/enclose second floor door opening, remove Insulbrick siding, replace concrete patio with 10’ x 13’ wood deck, replace single door leading to patio/deck with sliding door unit, and expand second floor shed dormer, per the submitted documents, drawings, photographs, and product data.***

The reasons for the denial are a failure to meet the following specific Standards or Elements:

- ***Standard 2 - The historic character of a property shall be retained and preserved. The removal of historic materials or alteration of features and spaces that characterize a property shall be avoided.***
- ***Standard 5 – Distinctive features, finishes, and construction techniques or examples of craftsmanship that characterize a property shall be preserved***
- ***Standard 6 – Deteriorated historic features shall be repaired rather than replaced. Where the severity of deterioration requires replacement of a distinctive feature, the new feature shall match the old in design, color, texture, and other visual qualities and, where possible, materials. Replacement of missing features shall be substantiated by documentary, physical, or pictorial evidence***

The application may be resubmitted for the Historic District Commission's review when suggested changes have

been made that address the cited reasons for denial, if applicable.

Please be advised that, in accordance with MCL 399. 211 and Section 21-2-81 of the 2019 Detroit City Code, an applicant aggrieved by a decision of the DHDC may file an appeal with the State Historic Preservation Review Board. Within sixty (60) days of your receipt of this notice, an appeal may be filed with:

Jon Stuckey, Michigan Department of Attorney General
2nd Floor, G. Mennen Williams Building
525 West Ottawa Street
P.O. Box 30754
Lansing, MI 48909

Phone: 517-335-0665
E-mail: stuckeyj@michigan.gov

If you have any questions regarding the foregoing, please contact staff at 313-224-1762 or hdc@detroitmi.gov.

For the Commission:

A handwritten signature in black ink, appearing to read "Audra Dye", enclosed within a thin black rectangular border.

Audra Dye
Detroit Historic District Commission

DHDC 22-8012

APPROVAL DOCUMENT – POST AT WORK LOCATION



CITY OF DETROIT
HISTORIC DISTRICT COMMISSION

2 WOODWARD, SUITE 808
DETROIT, MICHIGAN 48226

September 21, 2022

CERTIFICATE OF APPROPRIATENESS

Brooke Schwartz & Steve Edelman
768 Bird Avenue
Birmingham, MI 48009

RE: Application Number 22-8012; 1556 Bagley; Corktown Historic District

Dear Applicant,

At the Regular Meeting that was held on September 14, 2022, the Detroit Historic District Commission (“DHDC”) reviewed the above-referenced application. Pursuant to Section 5(1) of the Michigan Local Historic District Act, as amended, being MCL 399.205 (1) and Sections 21-2-73/21-2-78 of the 2019 Detroit City Code; the DHDC hereby issues a Certificate of Appropriateness (“COA”) for the following work, effective on September 21, 2022, as it meets the Secretary of Interior’s Standards for Rehabilitation and the district’s Elements of Design:

Repair and paint white existing front porch, replace windows on the sides and rear of the house (and single opening front elevation window), reduce size of first floor rear window, remove/enclose second floor door opening, remove Insulbrick siding, replace concrete patio with 10’ x 13’ wood deck, replace single door leading to patio/deck with sliding door unit, and expand second floor shed dormer, per the submitted documents, drawings, photographs, and product data.

With the conditions that:

- ***The rear elevation sliding door shall be wood, aluminum-clad wood or fiberglass frame; the cut sheet confirming all details, dimensions and finishes will be submitted for staff review.***
- ***A site plan confirming the footprint of the deck, and a dimensioned detail of the railing to be constructed at the deck’s west edge, will be submitted for staff review.***
- ***Elevation drawings that detail the proposed extended wall at the second floor, as well as the enclosure of the second-floor door and related roof work, will be submitted to staff for review.***

Please retain this COA for your files and post it at the subject property until work is complete. It is important to note that approval by the DHDC does not waive the applicant's responsibility to comply with any other applicable ordinances or statutes. If you have any questions regarding the foregoing, please contact staff at 313-224-1762 or hdc@detroitmi.gov.

For the Commission:

A handwritten signature in black ink, appearing to read "Audra Dye".

Audra Dye
Detroit Historic District Commission

P2 - BUILDING PERMIT APPLICATION

Date: 7-11-2022

PROPERTY INFORMATION

Address: 1556 BAGLEY Floor: Suite#: Stories: 2

AKA: Lot(s): Subdivision:

Parcel ID#(s): 000393 / ward 8 Total Acres: .08 Lot Width: 25' Lot Depth: 130'

Current Legal Use of Property: duplex Proposed Use: SFR

Are there any existing buildings or structures on this parcel? [X] Yes [] No

PROJECT INFORMATION

Permit Type: [] New [X] Alteration [] Addition [X] Demolition [] Correct Violations

[] Foundation Only [X] Change of Use [] Temporary Use [] Other:

[] Revision to Original Permit #: (Original permit has been issued and is active)

Description of Work (Describe in detail proposed work and use of property, attach work list)

Convert to single family residence. Cosmetic updates.

[] MBC use change [] No MBC use change

Included Improvements (Check all applicable; these trade areas require separate permit applications)

[X] HVAC/Mechanical [X] Electrical [X] Plumbing [] Fire Sprinkler System [] Fire Alarm

Structure Type

[] New Building [X] Existing Structure [] Tenant Space [] Garage/Accessory Building

[] Other: Size of Structure to be Demolished (LxWxH) cubic ft.

Construction involves changes to the floor plan? [] Yes [X] No

(e.g. interior demolition or construction to new walls)

Use Group: Type of Construction (per current MI Bldg Code Table 601)

Estimated Cost of Construction \$ 150,000 By Contractor \$ By Department

Structure Use

[X] Residential-Number of Units: 1 [] Office-Gross Floor Area [] Industrial-Gross Floor Area

[] Commercial-Gross Floor Area [] Institutional-Gross Floor Area [] Other-Gross Floor Area

Proposed No. of Employees: List materials to be stored in the building:

PLOT PLAN SHALL BE submitted on separate sheets and shall show all easements and measurements (must be correct and in detail). SHOW ALL streets abutting lot, indicate front of lot, show all buildings, existing and proposed distances to lot lines. (Building Permit Application Continues on Next Page)

For Building Department Use Only

Intake By: Date: Fees Due: DngBld? [] No

Permit Description:

Permit #:

Current Legal Land Use: Proposed Use:

Permit#: Date Permit Issued: Permit Cost: \$

Zoning District: Zoning Grant(s):

Lots Combined? [] Yes [] No (attach zoning clearance)

Revised Cost (revised permit applications only) Old \$ New \$

Structural: Date: Notes:

Zoning: Date: Notes:

Other: Date: Notes:



IDENTIFICATION (All Fields Required)

Property Owner/Homeowner Property Owner/Homeowner is Permit Applicant

Name: BROOKE SCHWARTZ Company Name: _____
Address: 768 BIRD AVE. City: B'HAM State: MI Zip: 48069
Phone: 248-234-0153 Mobile: SAME
Driver's License #: 8632098603645 Email: Brookschwartz@gmail.com

Contractor Contractor is Permit Applicant

Representative Name: STEVE EDELMAN Company Name: Redevelop Properties LLC
Address: 31262 W. RUTLAND City: BEV HILLS State: MI Zip: 48025
Phone: 248-939-3473 Mobile: SAME Email: eddel2eddel@gmail.com
* City of Detroit License #: _____

TENANT OR BUSINESS OCCUPANT Tenant is Permit Applicant

Name: _____ Phone: _____ Email: _____

ARCHITECT/ENGINEER/CONSULTANT Architect/Engineer/Consultant is Permit Applicant

Name: BOB WALTER State Registration#: _____ Expiration Date: _____
Address: 14899 TOWERING OAKS City: SILVERDALE State: MI Zip: 48315
Phone: _____ Mobile: _____ Email: _____

HOMEOWNER AFFIDAVIT (Only required for residential permits obtained by homeowner.)

I hereby certify that I am the legal owner and occupant of the subject property and the work described on this permit application shall be completed by me. I am familiar with the applicable codes and requirements of the City of Detroit and take full responsibility for all code compliance, fees and inspections related to the installation/work herein described. I shall neither hire nor sub-contract to any other person, firm or corporation any portion of the work covered by this building permit. MIA

Print Name: Brooke Schwartz Signature: [Signature] Date: _____
(Homeowner)

Subscribed and sworn to before me this _____ day of _____ 20 _____ A.D. _____ County, Michigan
Signature: _____ My Commission Expires: _____
(Notary Public)

PERMIT APPLICANT SIGNATURE

I hereby certify that the information on this application is true and correct. I have reviewed all deed restrictions that may apply to this construction and am aware of my responsibility thereunder. I certify that the proposed work is authorized by the owner of the record and I have been authorized to make this application as the property owner(s) authorized agent. Further I agree to conform to all applicable laws and ordinances of jurisdiction. I am aware that a permit will expire when no inspections are requested and conducted within 180 days of the date of issuance or the date of the previous inspection and that expired permits cannot be

Print Name: Steven Edelman Signature: [Signature] Date: _____
(Permit Applicant)

Driver's License #: E345 777373843 Expiration: 11/02/2022
Subscribed and sworn to before me this _____ day of _____ 20 _____ A.D. _____ County, Michigan
Signature: _____ My Commission Expires: _____
(Notary Public)

Section 23a of the state construction code act of 1972, 1972PA230, MCL 125.1523A, prohibits a person from conspiring to circumvent the licensing requirements of this state relating to persons who are to perform work on a residential building or a residential structure. Visitors of Section 23a are subject to civil fines.

This application can also be completed online. Visit detroitmi.gov/bseed/elaps for more information.



THIS IS A 3-PAGE FORM - ALL INFORMATION IS REQUIRED FOR PROJECT REVIEW

HISTORIC DISTRICT COMMISSION PROJECT REVIEW REQUEST

City of Detroit - Planning & Development Department
2 Woodward Avenue, Suite 808
Detroit, Michigan 48226

DATE: _____

PROPERTY INFORMATION

ADDRESS(ES): 1556 BAGLEY AKA: _____

PARCEL ID: 000393 / WARD 8 HISTORIC DISTRICT: CORKRAN

SCOPE OF WORK: (Check ALL that apply)

<input checked="" type="checkbox"/> Windows/ Doors	<input checked="" type="checkbox"/> Walls/ Siding	<input checked="" type="checkbox"/> Painting	<input checked="" type="checkbox"/> Roof/Gutters/ Chimney	<input checked="" type="checkbox"/> Porch/Deck/ Balcony	<input type="checkbox"/> Addition
<input checked="" type="checkbox"/> Demolition	<input type="checkbox"/> Signage	<input type="checkbox"/> New Building	<input checked="" type="checkbox"/> Major Alteration (3+ scope items)	<input checked="" type="checkbox"/> Site Improvements (landscape, trees, fences, patios, etc.)	

BRIEF PROJECT DESCRIPTION: Update Finishes, convert to SFR

APPLICANT IDENTIFICATION

Property Owner/
Homeowner Contractor Tenant or
Business Occupant Architect/Engineer/
Consultant

NAME: Brake Schwartz COMPANY NAME: _____

ADDRESS: 768 Bird Ave. CITY: Birmingham STATE: MI ZIP: 48009

PHONE: 248-234-0153 MOBILE: SAME EMAIL: Brodekmschwartz@gmail.com

PROJECT REVIEW REQUEST CHECKLIST

Please attach the following documentation to your request:

PLEASE KEEP FILE SIZE OF ENTIRE SUBMISSION UNDER 30MB

Completed Building Permit Application
(highlighted portions only)

ePLANS Permit Number (only applicable if you've already
applied for permits through ePLANS)

Current Photographs: Including the front of the building & detailed photographs of the area(s) affected by
the proposed work. All photographs must be labeled or captioned, e.g. "west wall", "second floor window," etc.

Description of existing conditions (including materials and design)

Description of project (if replacing any existing material(s), include an explanation as to why
replacement--rather than repair--of existing and/or construction of new is required)

Detailed scope of work (formatted as bulleted list)

Brochure/cut sheets for proposed replacement material(s) and/or product(s), as applicable

Upon receipt of this documentation, staff will review and inform you of the next steps toward obtaining your building
permit from the Buildings, Safety Engineering and Environmental Department (BSEtED) to perform the work.

SUBMIT COMPLETED REQUESTS TO: HDC@DETROITMI.GOV

NOTE:

Based on the scope of work, additional
documentation may be required.

See www.detroitmi.gov/hdc for scope-
specific requirements.

REAR ELEVATION - WINDOWS

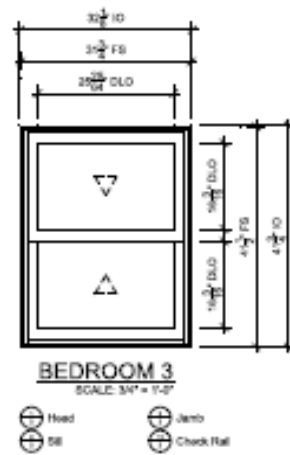
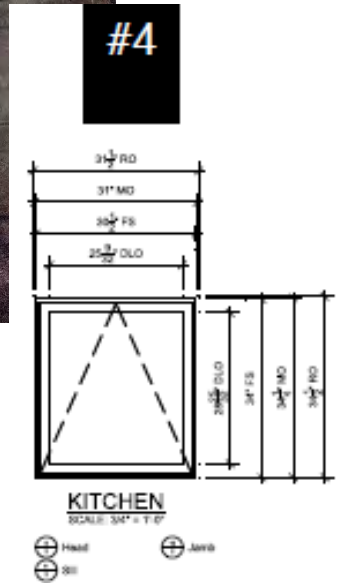

#11

REAR ELEVATION - DOORS

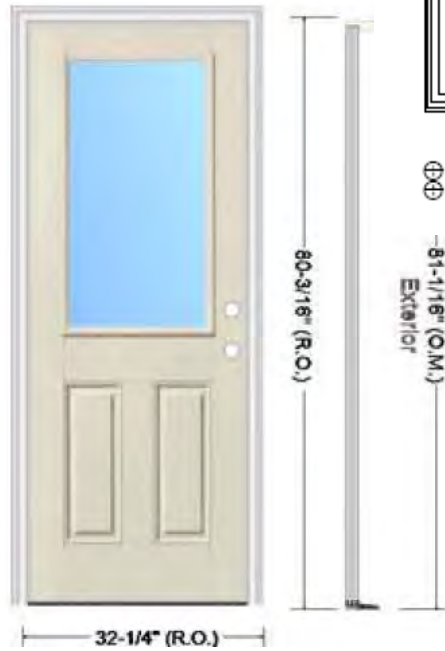
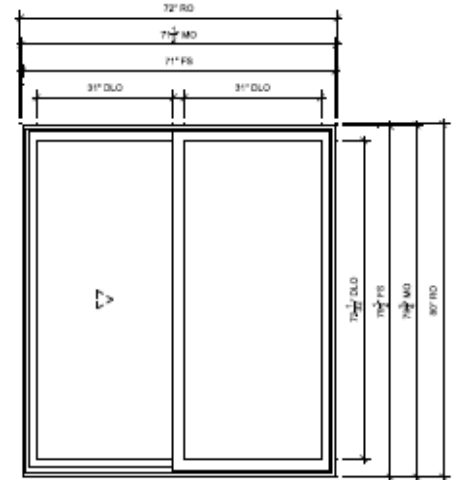

BREAKFAST NOOK

SCALE: 3/4\"/>



-81-11/8\"/>

Exterior

WEST – SIDE ELEVATION

NEAR FRONT PORCH

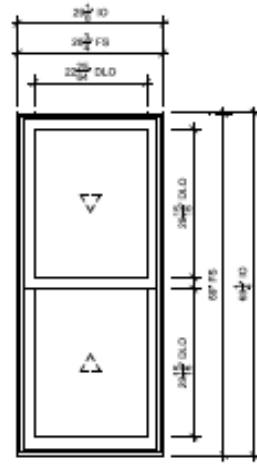

BAR
SCALE: 3/4" = 1'-0"



#10

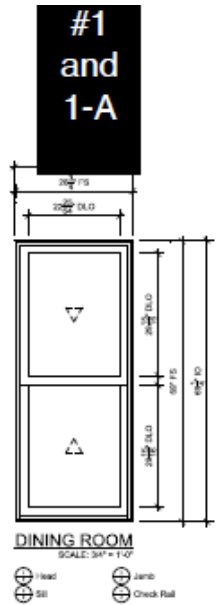

DINING ROOM
SCALE: 3/4" = 1'-0"

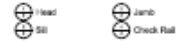

#1 and 1-A

WEST – SIDE ELEVATION NEAR REAR YARD

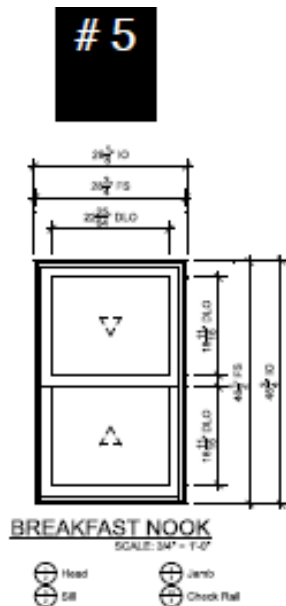

BREAKFAST NOOK
SCALE: 3/4" = 1'-0"



#5

EAST – SIDE ELEVATION



Is #2 the middle one?



3 and 3-A



BATHROOM
SCALE: 3/4" = 1'-0"

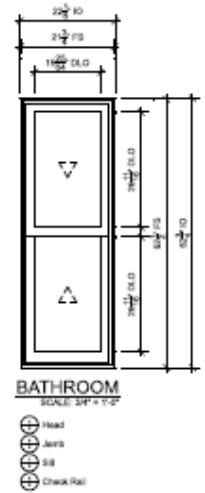

BATHROOM
SCALE: 3/4" = 1'-0"

EAST ELEVATION

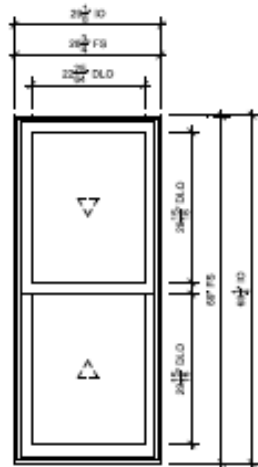

BEDROOM 1
SCALE: 3/4\"/>

- ⊕ Head
- ⊕ Sill
- ⊕ Jamb
- ⊕ Check Rail

#9

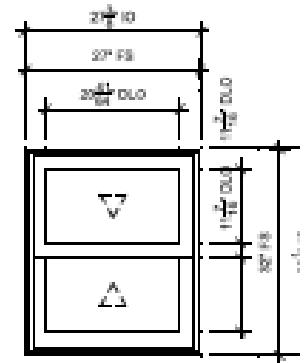

BATHROOM
SCALE: 3/4\"/>

- ⊕ Head
- ⊕ Jamb
- ⊕ Sill
- ⊕ Check Rail

#12

FRONT ELEVATION



#8

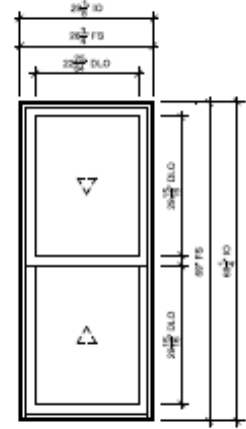

MASTER BEDROOM
SCALE: 3/4" = 1'-0"

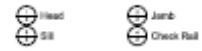

1556 BAGLEY OVERVIEW - UPDATED VERSION 9/1

SCOPE OF WORK

We are planning to do a renovation of the interior and exterior of 1556 Bagley. All mechanicals and finishes will be updated. The site will be re landscaped with a combination of plants and hardscape. We will maintain all the original exterior design elements, and we will refurbish or replace them with the same materials wherever possible. The exterior will remain painted all white as is evident in current photos.

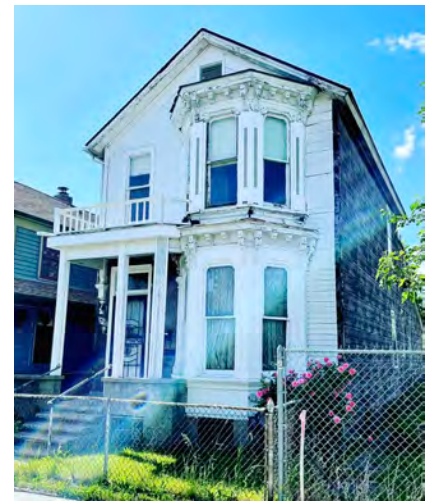

WINDOWS

After examination we have determined we will be attempting to refurbish all the windows and doors on the front elevation of the house which faces Bagley. They are all wood in various stages of disrepair. This will preserve the overall character of the home.

On all the remaining sides of the house we will be replacing the windows. We chose Marvin Elevate Windows which are fiberglass clad on the outside and wood on the inside. The reason we chose these is energy efficiency, cost effectiveness, as well as quality. These will preserve the exterior aesthetics of the house as well as enhance the interior. You will see on the photos many of the windows are rotten, chipping, broken, non functioning.

The west side of the house is up against a neighboring house. We will be replacing all of the windows on this side of the house. The one window we are altering the size of is in what we are calling the Kitchen and faces the rear yard. We need to shorten this window to accommodate our lower kitchen cabinets.

The rear of the house will have some window changes as well. One of the first floor rear door will become a sliding glass door wall leading from the breakfast room onto the new deck and back yard. The other door on this level will remain - it will just be updated with a new door. This door provides access to the basement and into the breakfast room as well.

On the second floor of the rear of the house there is currently a door which is very hazardous as it leads from the second floor bathroom out onto the roof of the house. We will eliminate this door altogether. This is where we will also raise one of two adjacent rooflines. This will give additional height to the second floor bathroom as well as help to improve the aesthetics of the rear elevation of the house. (You can see this in as built drawing we have included in this package). There is a vent near the top gable which will remain. The existing window on the east elevation(12) will remain in position but will be replaced with a new window of the same size. This window currently is installed incorrectly and we want all the windows to match as well. See sketch and photo under REAR ELEVATION section of this report.

On the east facing side of the house we will be replacing all the windows. The current wood windows are in varying stages of disrepair, rotted wood, broken glass etc. One of the windows on the second floor looks a bit newer, but it is not installed properly and we wish to have all the windows match from the exterior so we decided to replace that one as well.

We are including pictures of each that you can toggle to the corresponding spec sheets from Marvin. Each window has been numbered and has room description.

FRONT PORCH



The existing front porch is built from cinderblock for the walls with a cement cap and also with a cement floor. This porch is suffering structurally and is sinking and cracking causing a hazard. After further consideration we decided this will be made structurally sound from underneath by getting access in the basement, then the floor will be re poured in cement. The original footprint of the porch and stairs will remain as it is now. The cinderblock walls of the porch will be tuck pointed and repaired. This will all be painted white to match the exterior. The stairs up onto the front porch from the street are also currently cement with exposed wires and cracks. We will re build these steps with 13 inch steps and 7.5 inch risers and these will be poured with new cement as well. The existing railing is wrought iron and is solidly attached to the footings and the house. We will keep this in place and paint it to match exterior.

EXTERIOR SIDING

The exterior of the house is currently wood siding covered with Insulbrick. On the two sides of the house, we will be removing the Insulbrick and all of the wood siding and replacing this with Hardie Board Siding. There is not currently proper insulation in this house. By removing the old siding we can rewrap the house to provide a water barrier and then insulate it properly. The Hardie product is long lasting and energy efficient while providing the aesthetics we want. The rear of the house is currently naked wood so it will be properly wrapped and then siding will be installed to match the sides on both first and second floors. The front facade will be restored using wood material where it is currently rotten and all the corbels and the second floor railing will be refurbished. We will not be altering anything aesthetically here. It will be painted white as well.

The soffits and fascia and window casings will be replaced with Hardie material and painted white to match the house. The gutters and downspouts will also be reused where possible or we will update them with new white gutters.

<https://www.homedepot.com/p/James-Hardie-HardiePlank-HZ5-5-16-in-x-8-25-in-x-144-in-Fiber-Cement-Primed-Cedarmill-Lap-Siding-6000265/202035444>

REAR ELEVATION

The rear of the house as mentioned prior, will have a new door wall from the breakfast room onto a new deck. Currently there is a 5' x 7' cement patio that is in disrepair with insecure steps down onto the lawn. This patio will be demolished. A new 10' x 13' deck will be erected with proper footings and clad in pressure treated wood stained in a clear coat to maintain a natural modern look. A small railing on the west side of the deck will be erected for safety. Stairs down to the lawn will be erected for safety.



INTERIOR STRUCTURAL REQUEST

We are including a letter from our structural engineer stating that we need modifications for the interior of the house. The first floor needs additional support as stated in his letter.

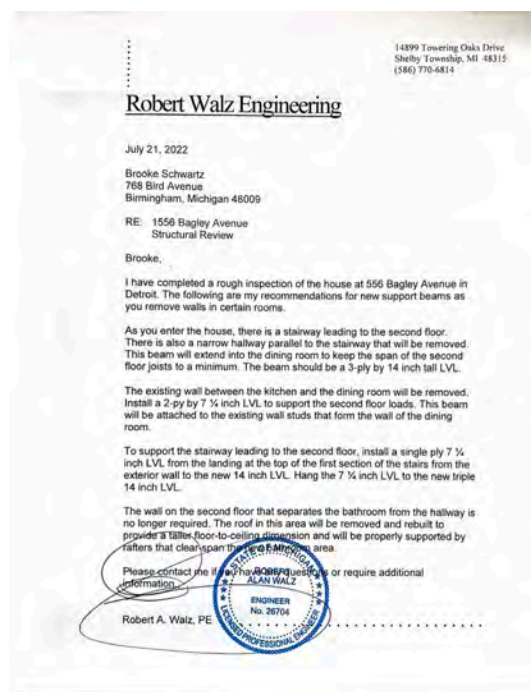

Planview porch - existing
materials
1556 Bagley

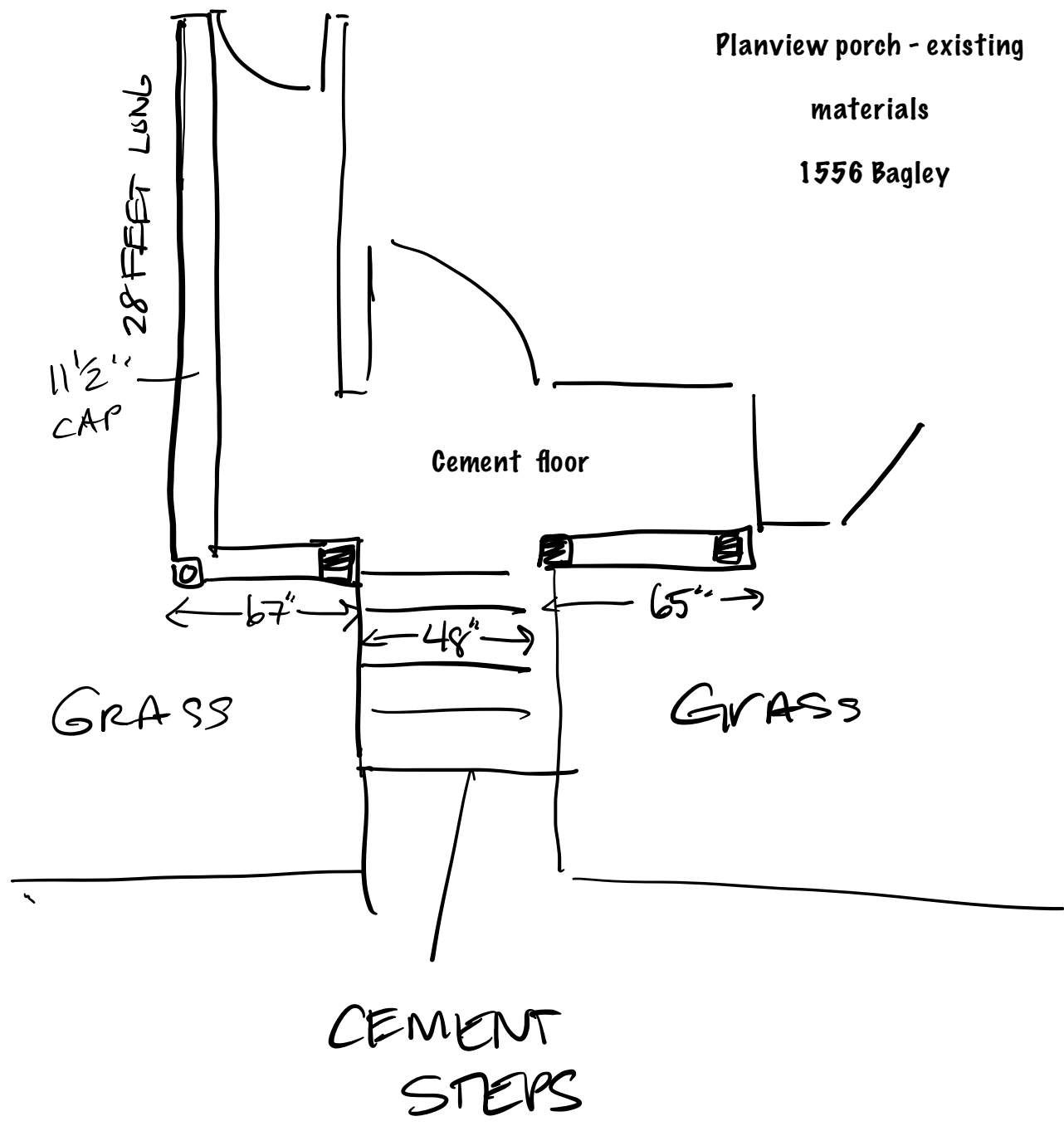

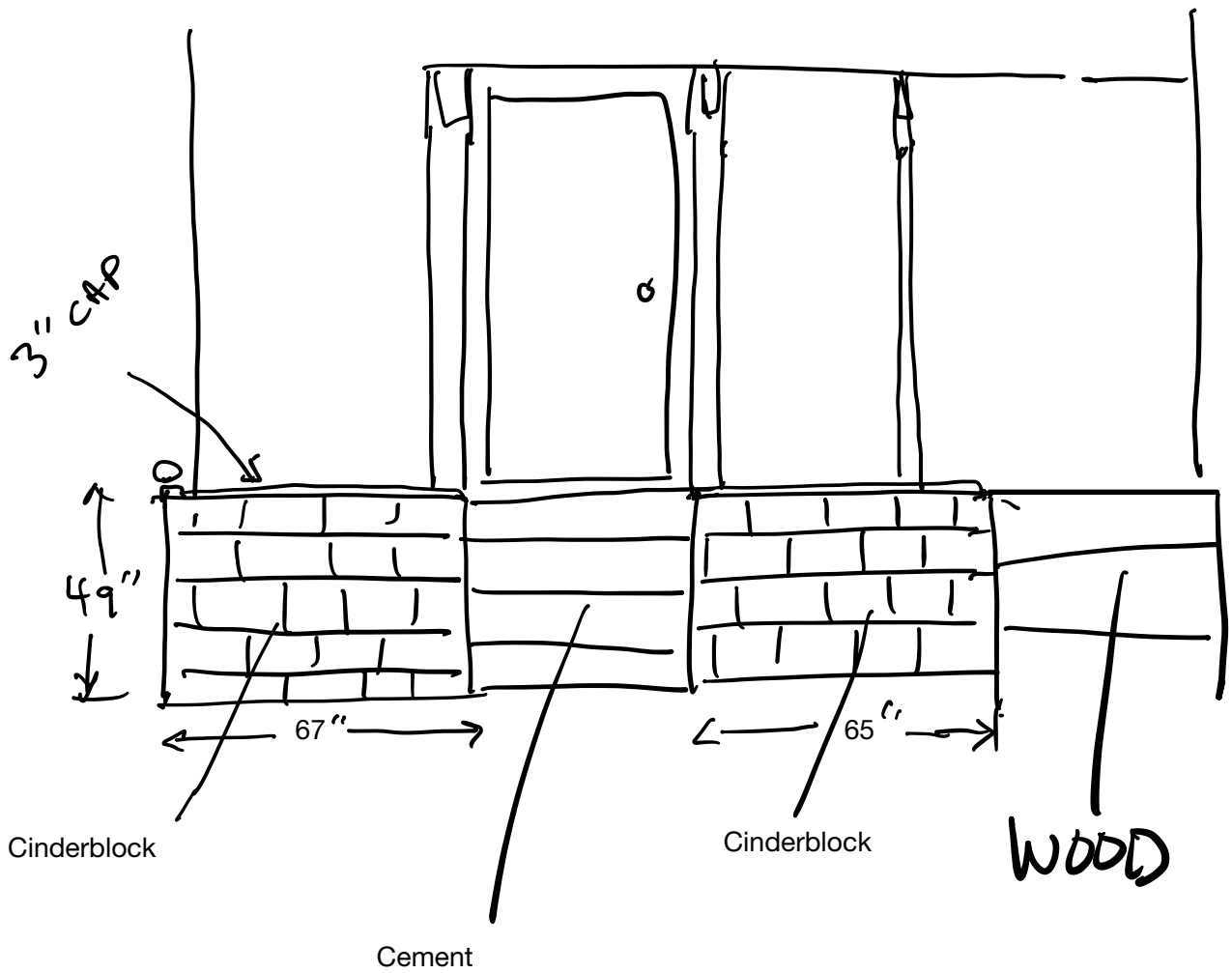

Elevation view -

Existing Materials

front porch

1556 Bagley

JR ARCHITECTURAL
DESIGN SERVICES, LLC.
16766 GREENLAWN ST
DETROIT, MI 48221
(410)-302-3414

AUTHOR: CLAIMS ALL COPYRIGHT
PROTECTIONS

PROJECT:

02-08-2022

**1556 BAGLEY
ROOF**
1556 BAGLEY ST.
DETROIT, MI
48216

DESIGNER

JR ARCHITECTURAL DESIGN
SERVICES, LLC
15785 Greenham St.
Detroit, MI 48221
(410)-302-2414

ARCHITECT OF RECORD

CONTRACTOR

LICENSE:

NOTES:

DRAWING TITLE:

DRAWN:

CHECKED:

SHEET NO.

A4

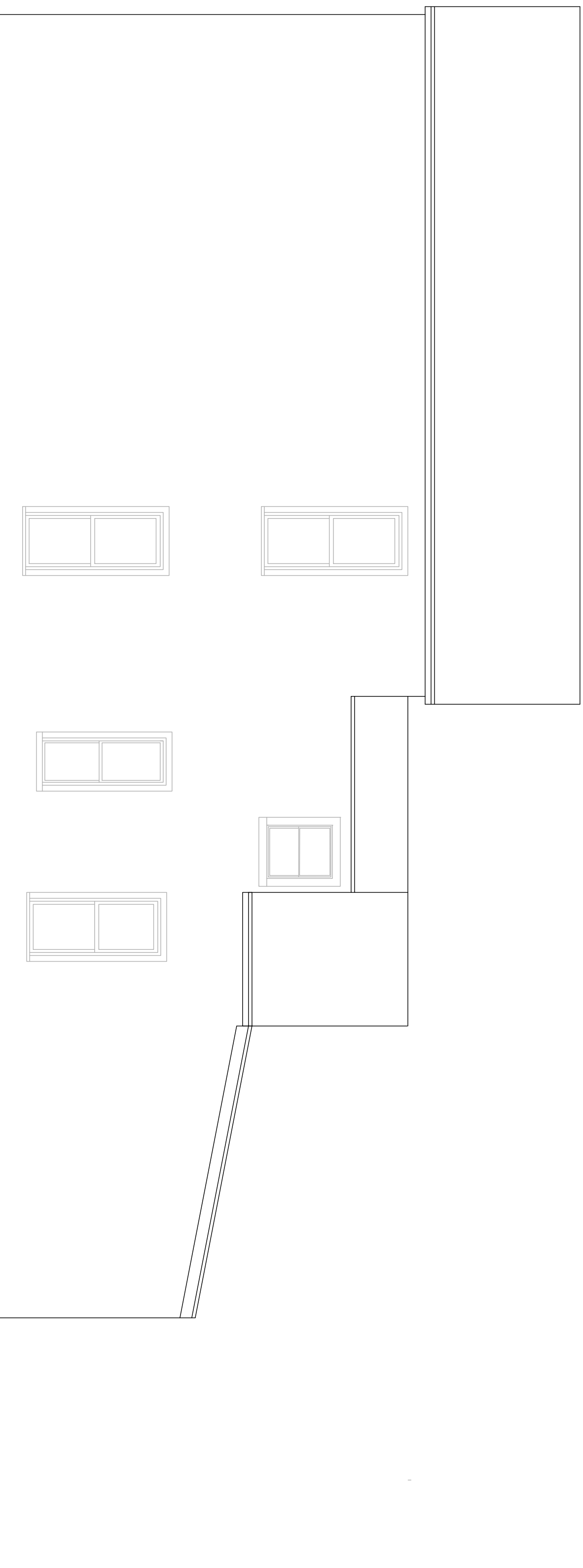

NORTHEAST ELEVATION
SCALE: 1/4" = 1'-0"

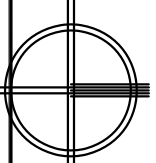

PRELIMINARY NOT FOR CONSTRUCTION

PRELIMINARY NOT FOR CONSTRUCTION

- REMOVE EXISTING ROOF AND RAFTERS
- REMOVE EXISTING DOOR AND INSTALL NEW 36X36 DOUBLE SLIDING WINDOW
- INSTALL 2X8 RAFTERS AT 16" ON CENTER FROM EXISTING PEAK TO THE TOP PLATE ON THE EXTERIOR WALL. SECURE IN PLACE WITH SIMPSON H2.5A HURRICANE CLIPS
- INSTALL ICE AND WATER SHIELD ON THE FIRST THREE FEET OF THE NEW ROOF AND 2 FEET AS FLASHING UP AND ALONG THE EXISTING WALL
- INSTALL SHINGLES OVER TAR PAPER OVER 3/4" THICK OSB SHEATHING. SHEATHING ATTACHED TO RAFTERS WITH 16D NAILS 4" ON CENTER
- INSTALL 1/2" OSB SHEATHING ON HOUSE WALL AND SIDING BELOW THE NEW WINDOW.

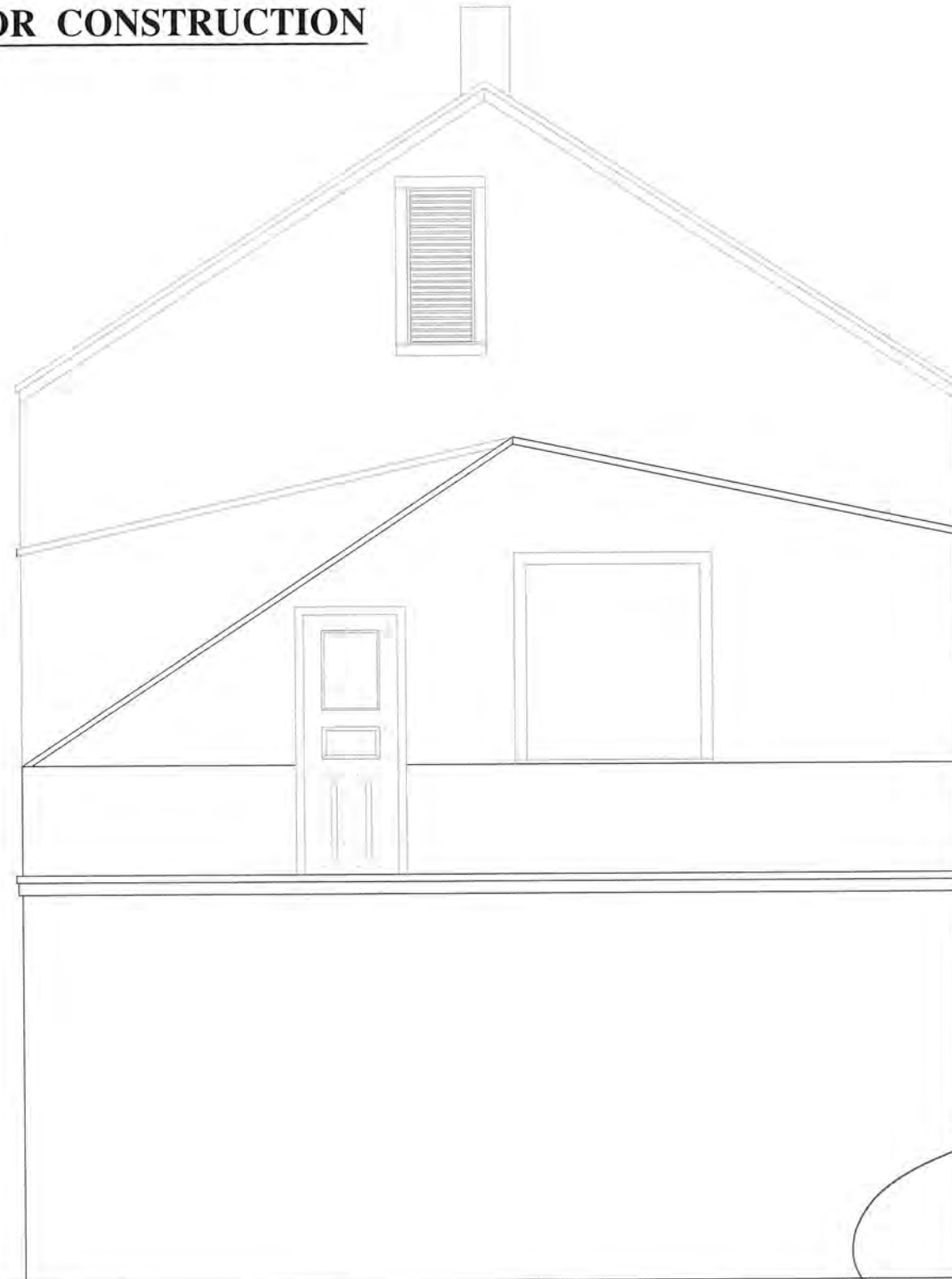

JR ARCHITECTURAL
DESIGN SERVICES, LLC.
16766 GREENLAWN ST
DETROIT, MI 48221
(410)-302-8414

AUTHOR CLAIMS ALL COPYRIGHT
PROTECTIONS

PROJECT:

1556 BAGLEY
ROOF
1556 BAGLEY ST.
DETROIT, MI
48216

DESIGNER

JR ARCHITECTURAL DESIGN
SERVICES, LLC.
16766 Greenlawn St.
Detroit, MI 48221
(410)-302-8414

ARCHITECT OF RECORD

CONTRACTOR

LICENSE:

NOTES:

DRAWING TITLE:

DRAWN:

CHECKED:

SHEET No.

A3

NORTHWEST ELEVATION

SCALE: 1/2" = 1'-0"

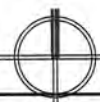



PRELIMINARY NOT FOR CONSTRUCTION

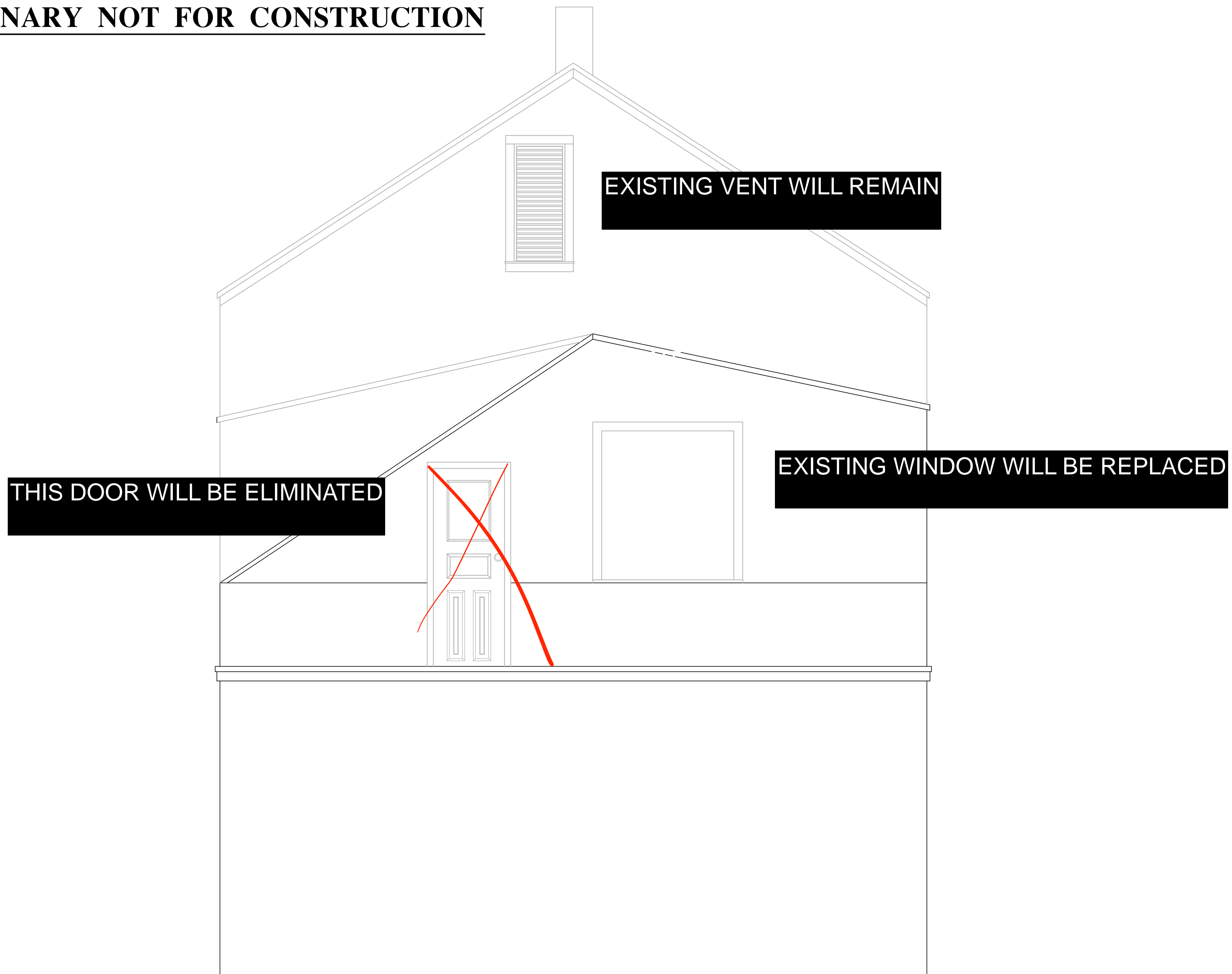

JR ARCHITECTURAL
DESIGN SERVICES, LLC.
16766 GREENLAWN ST
DETROIT, MI 48221
(410)-302-8414

AUTHOR CLAIMS ALL COPYRIGHT
PROTECTIONS

PROJECT:
**1556 BAGLEY
ROOF**
1556 BAGLEY ST.
DETROIT, MI
48216

DESIGNER
JR ARCHITECTURAL DESIGN
SERVICES, LLC.
16766 Greenlawn St.
Detroit, MI 48221
(410)-302-8414

ARCHITECT OF RECORD

CONTRACTOR

LICENSE:

NOTES:

DRAWING TITLE:

DRAWN:
CHECKED:

SHEET No.

A3

NORTHWEST ELEVATION
SCALE: 1/2" = 1'-0"

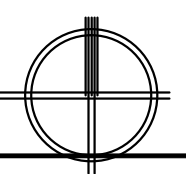

Imported File (2)

Sep 1, 2022 at 3:44 PM

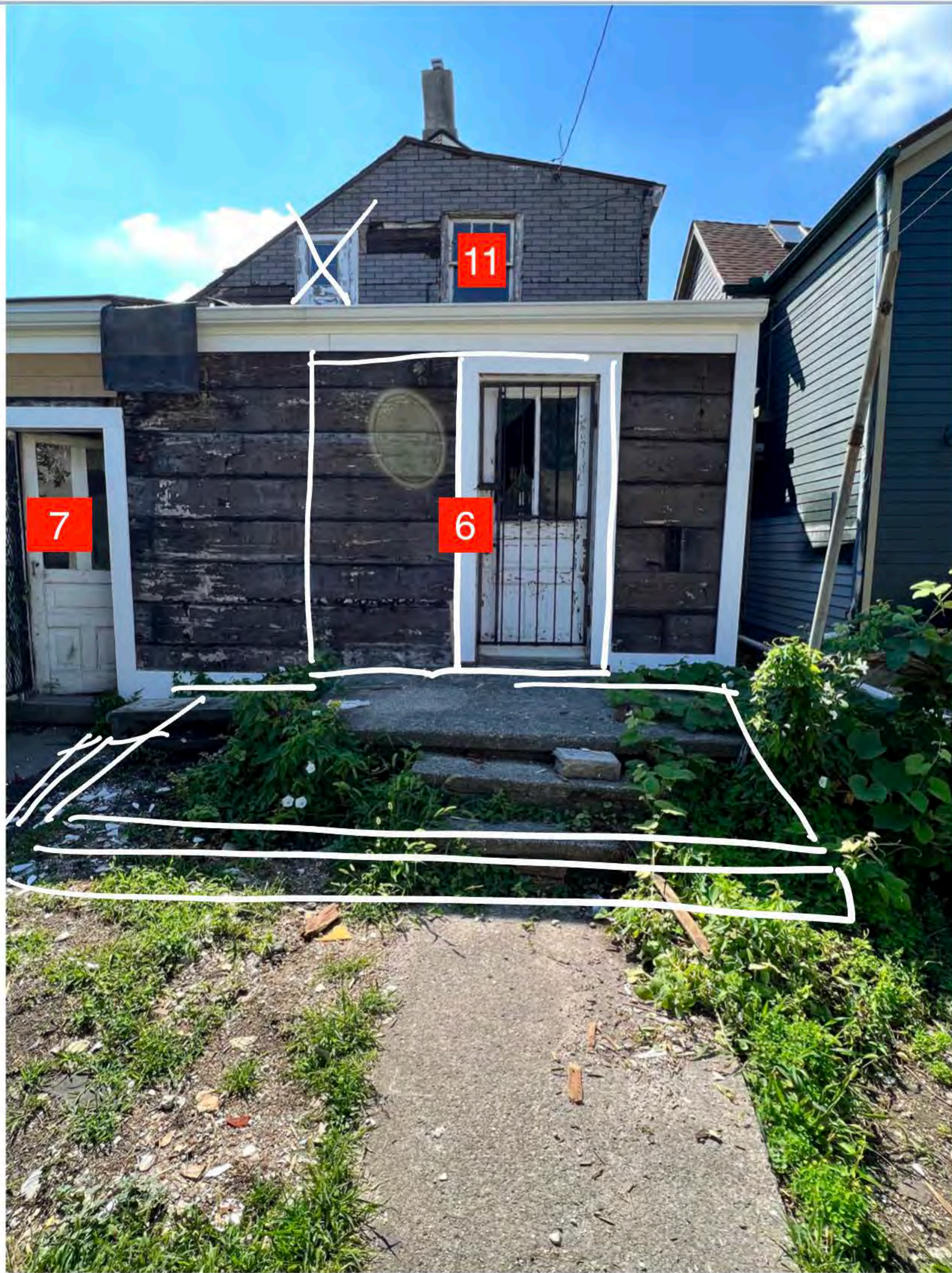



































ORDERING PRODUCTS WITH REFERENCE TO SHOP DRAWINGS:
 Before ordering the Marvin Window and Door products illustrated within these shop drawings, a copy of these drawings accompanied by an approved signature of the purchaser must be returned to the Architectural Department at Marvin Windows & Doors, P.O. Box 100, Grand Rapids, Michigan 49503. The purchaser must also return a copy of these drawings to the approved shop drawings. Marvin Windows and Doors assumes no responsibility in guaranteeing product coordination with the drawings.

REVISION:

CREATED: 07/22/2022

PK VERSION: 0003.15.00

PROJ/JOB: Edelman / Schwartz / Bagley Project - Marvin Elevate

DIST/DEALER: LAURENCE SMITH DIST INC

DRAWN: CHRIS CASWELL

QUOTE#: GJ48R4N

#1 and 1-A

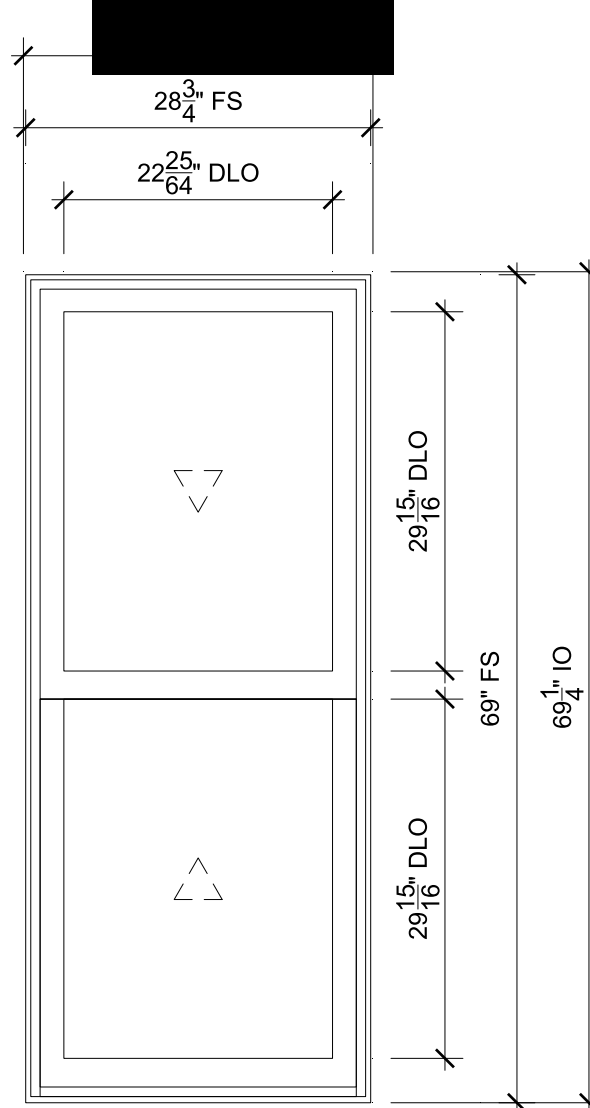

DINING ROOM
SCALE: 3/4" = 1'-0"
 Head, Jamb, Sill, Check Rail

#2

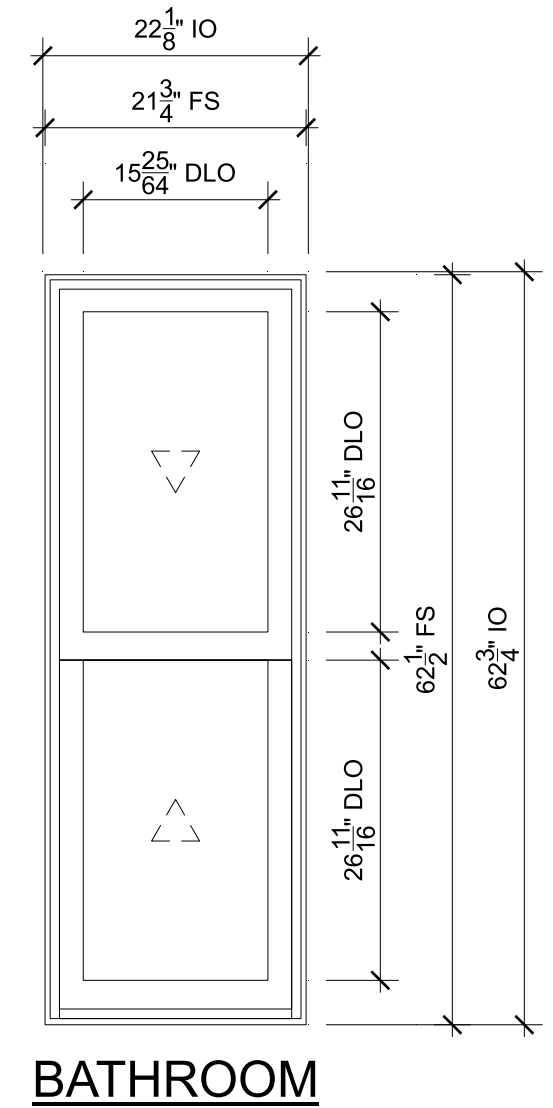

BATHROOM
SCALE: 3/4" = 1'-0"
 Head, Jamb, Sill, Check Rail

#3 and 3-A

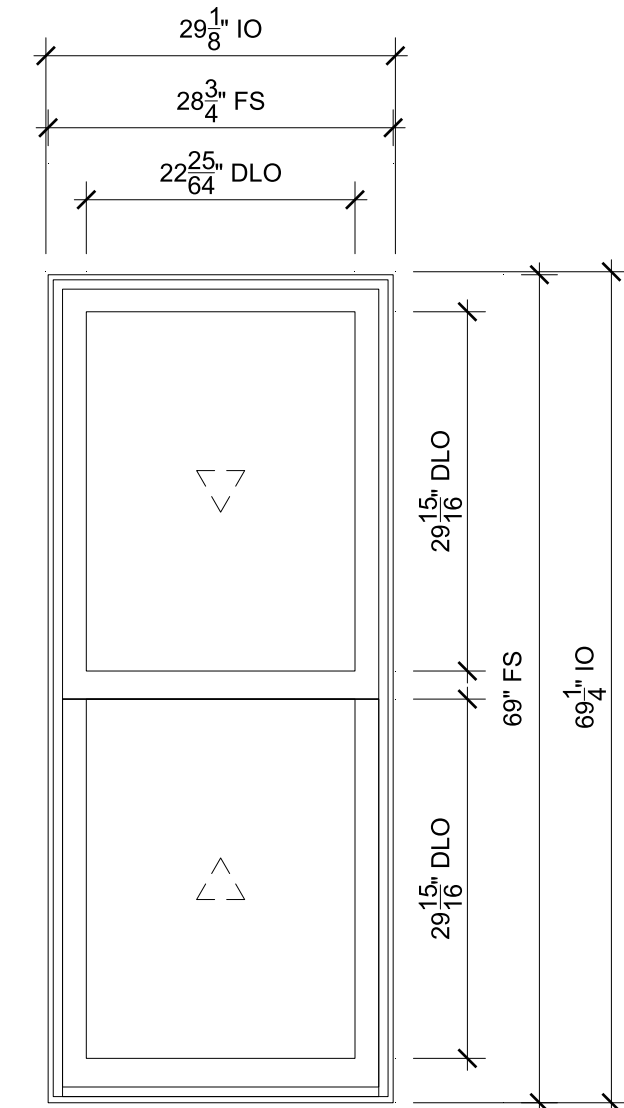

BATHROOM
SCALE: 3/4" = 1'-0"
 Head, Jamb, Sill, Check Rail

#4

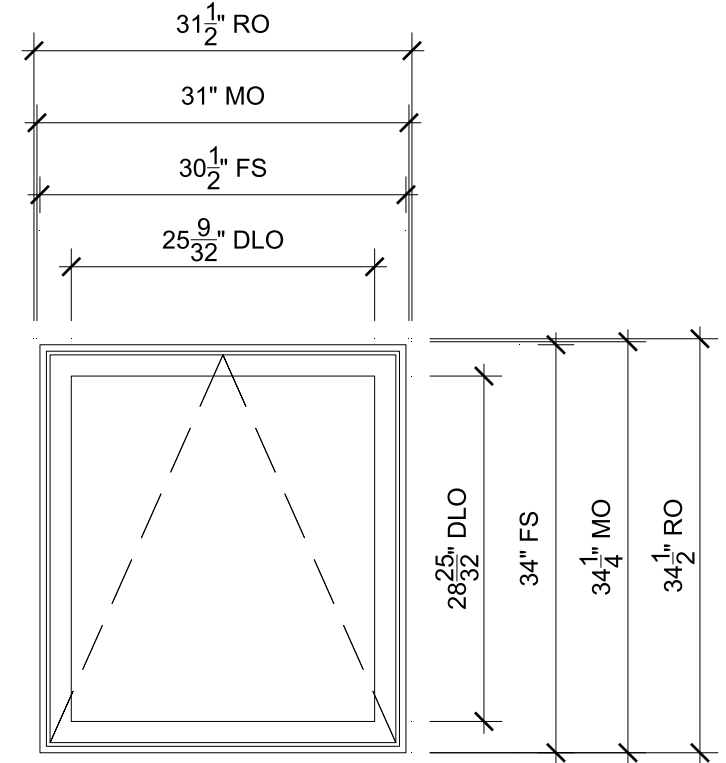

KITCHEN
SCALE: 3/4" = 1'-0"
 Head, Sill, Jamb, Check Rail

#5

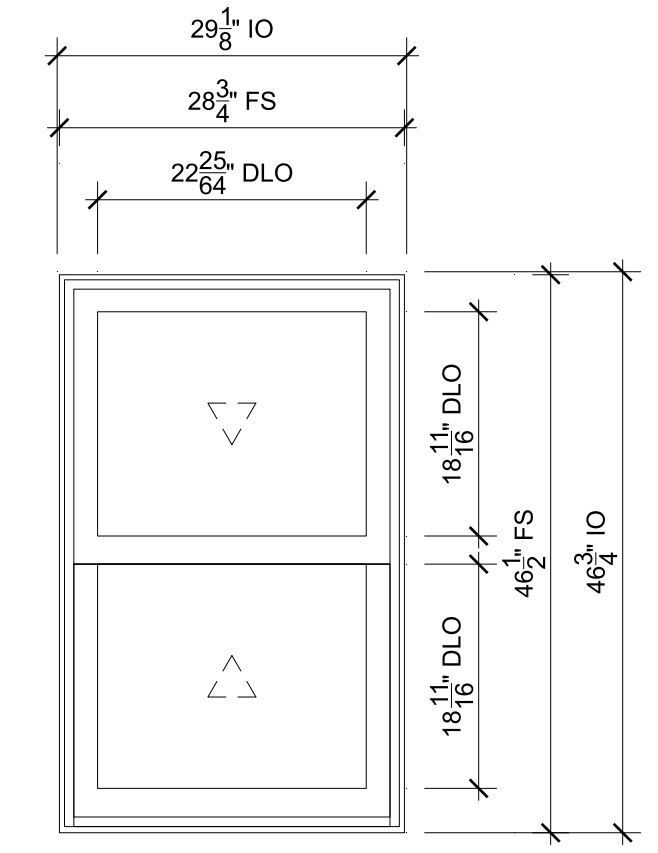

BREAKFAST NOOK
SCALE: 3/4" = 1'-0"
 Head, Sill, Jamb, Check Rail

#6

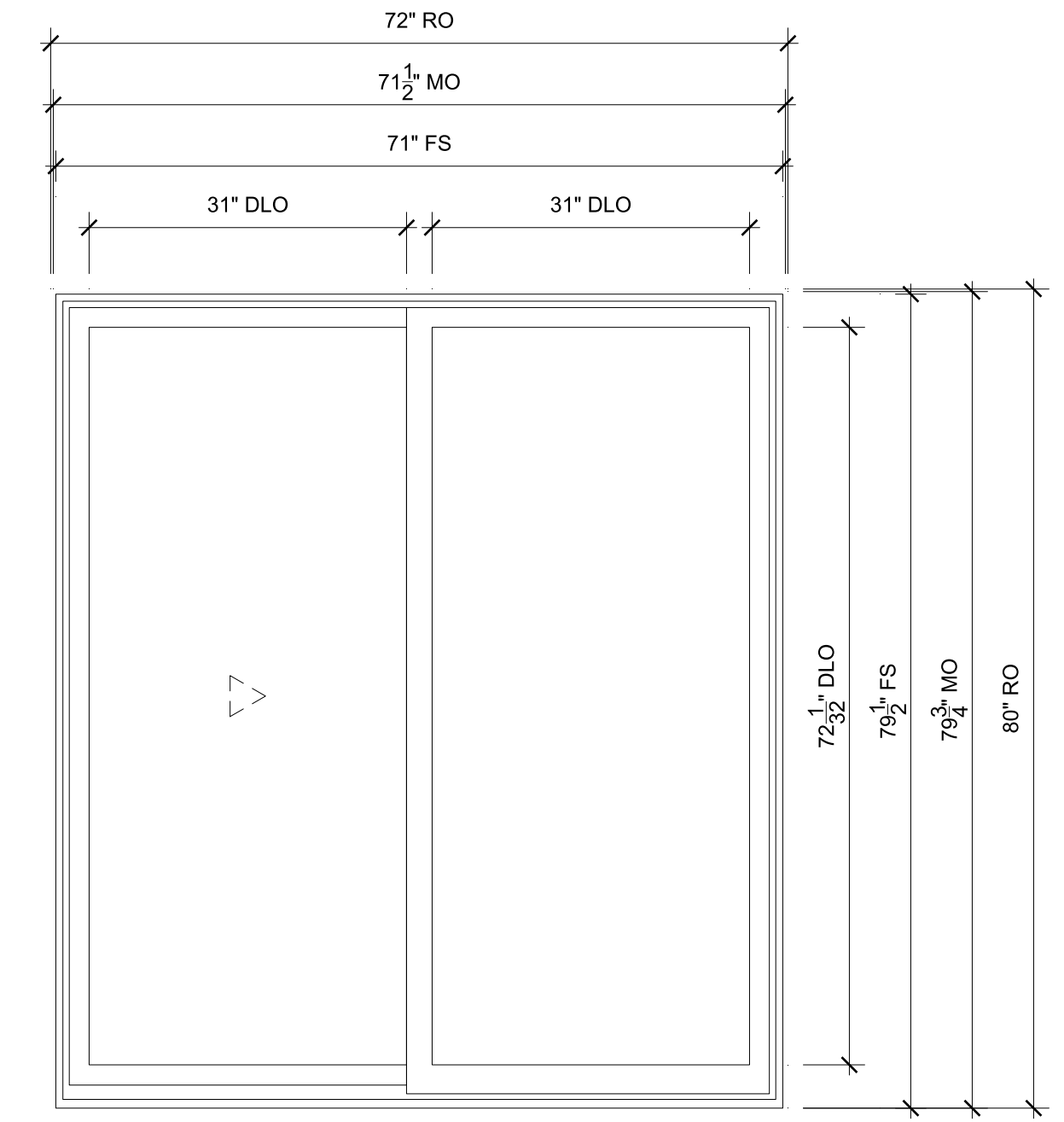

BREAKFAST NOOK
SCALE: 3/4" = 1'-0"
 Head, Meeting Stile, Jamb, Jamb, Sill

#8

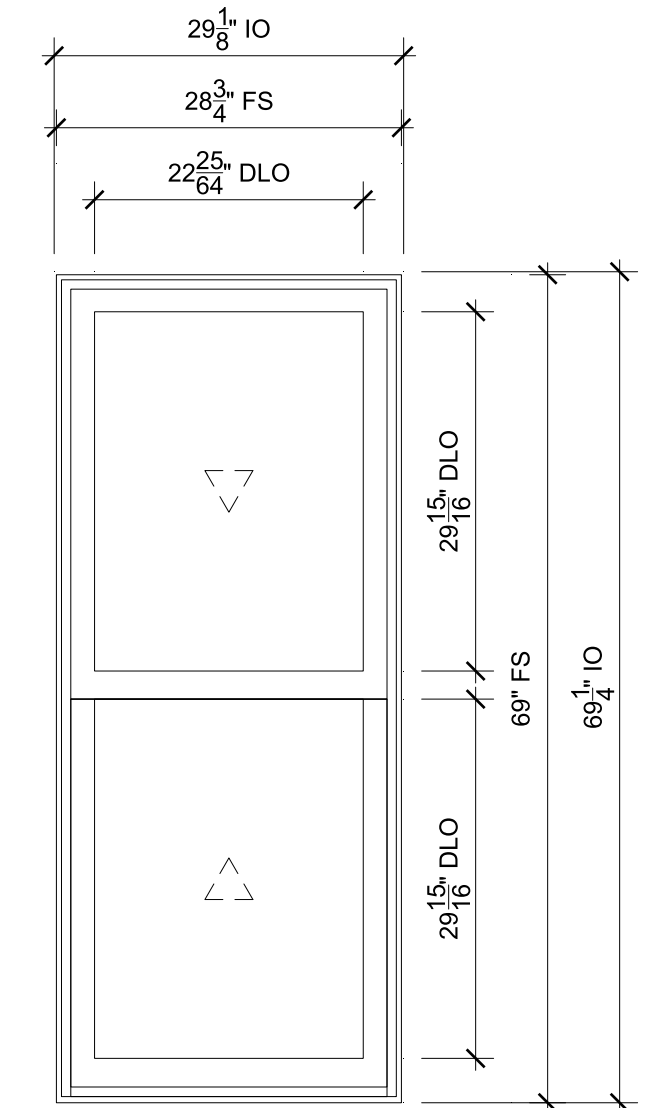

MASTER BEDROOM
SCALE: 3/4" = 1'-0"
 Head, Sill, Jamb, Check Rail

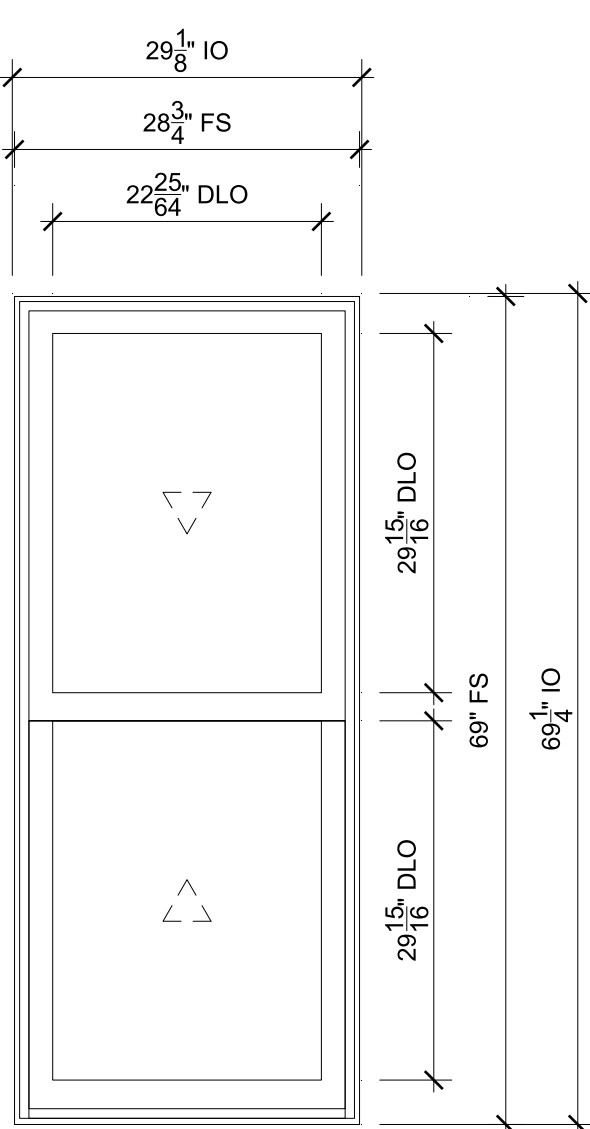

BEDROOM 1
SCALE: 3/4" = 1'-0"
 Head, Sill, Jamb, Check Rail

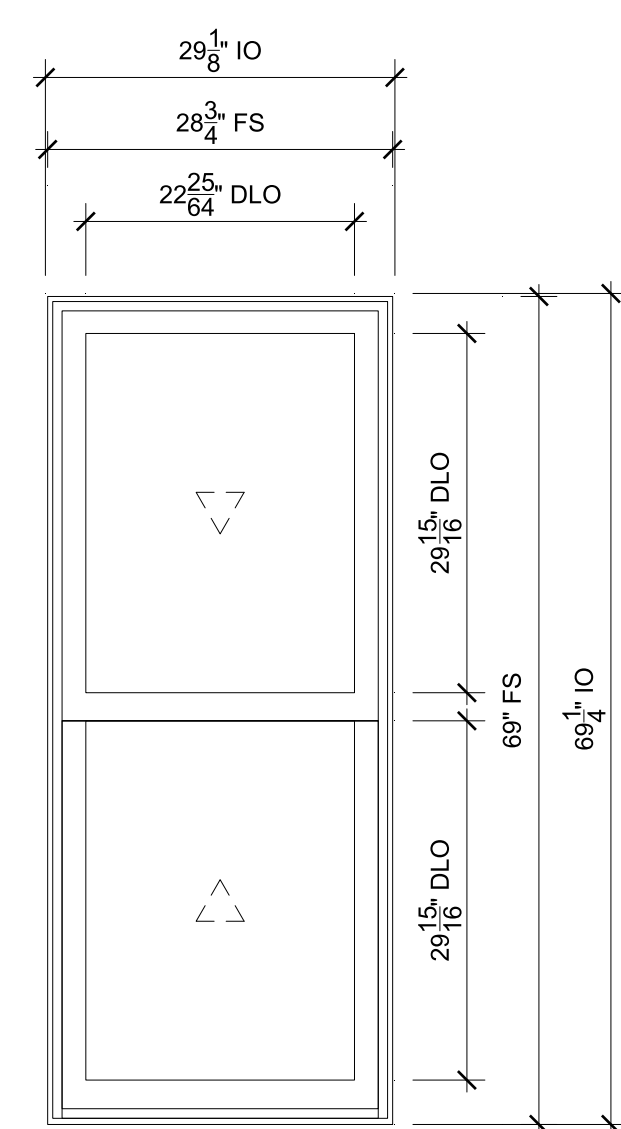

BAR
SCALE: 3/4" = 1'-0"
 Head, Sill, Jamb, Check Rail

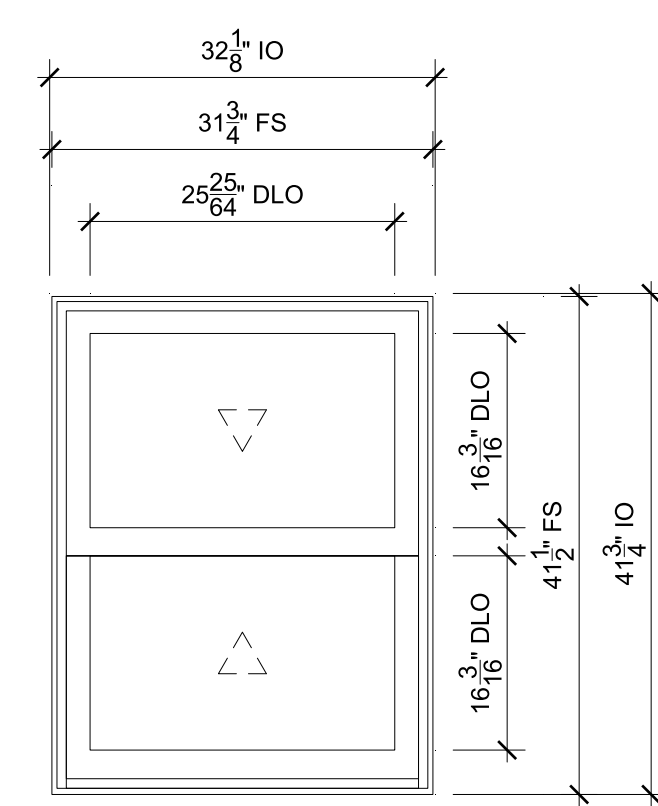

BEDROOM 3
SCALE: 3/4" = 1'-0"
 Head, Sill, Jamb, Check Rail

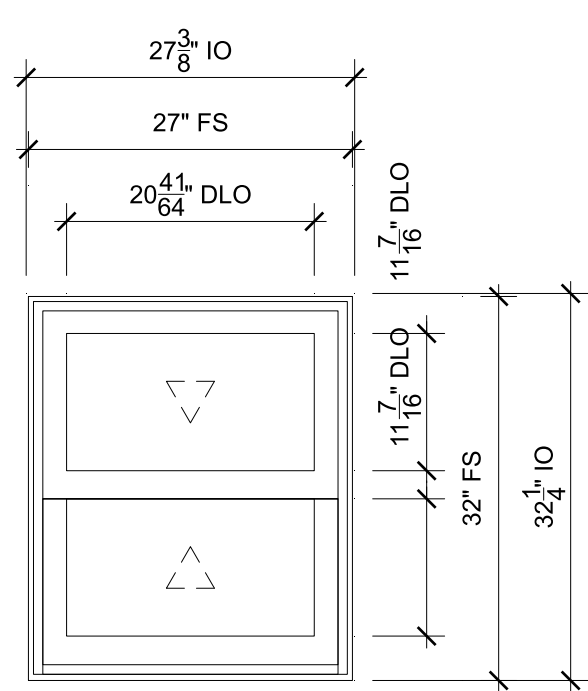

BATHROOM
SCALE: 3/4" = 1'-0"
 Head, Jamb, Sill, Check Rail

#9

#10

#11

#12

ORDERING PRODUCTS WITH REFERENCE TO SHOP DRAWINGS:
 Before ordering the Marvin Window and Door products illustrated within these shop drawings, a copy of these drawings accompanied by an approved signature of the purchaser must be returned to the Architectural Department, Marvin Windows & Doors, P.O. Box 100, Grand Rapids, Michigan 49503. The purchaser must also return a copy of these drawings to the approved shop drawings. Marvin Windows and Doors assumes no responsibility in guaranteeing product coordination with the drawings.

PROJECT: Edelman / Schwartz / Bagley Project - Marvin Elevate
 DIST/DEALER: LAURENCE SMITH DIST INC
 DRAWN: CHRIS CASWELL
 QUOTE#: GJ48R4N
 PK VERSION: 0003.15.00
 CREATED: 07/22/2022
 REVISION:

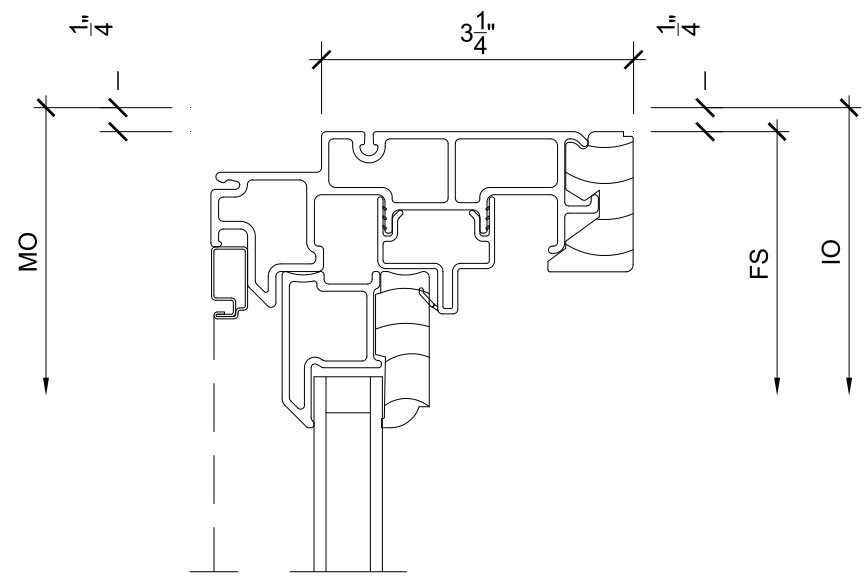

1
2 Head SCALE: 6" = 1'-0"

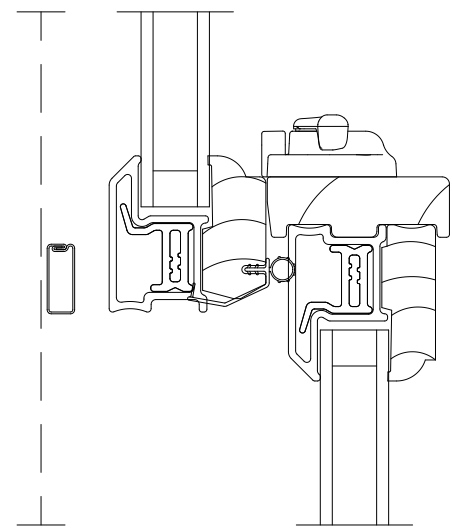

4
2 Check Rail SCALE: 6" = 1'-0"

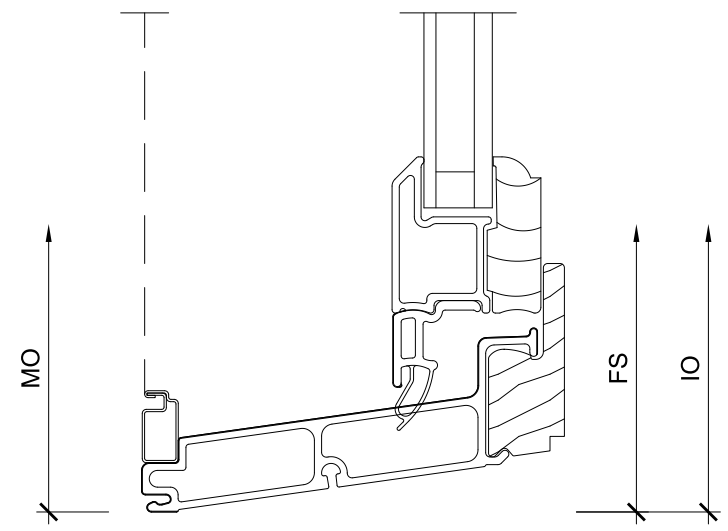

7
2 Sill SCALE: 6" = 1'-0"

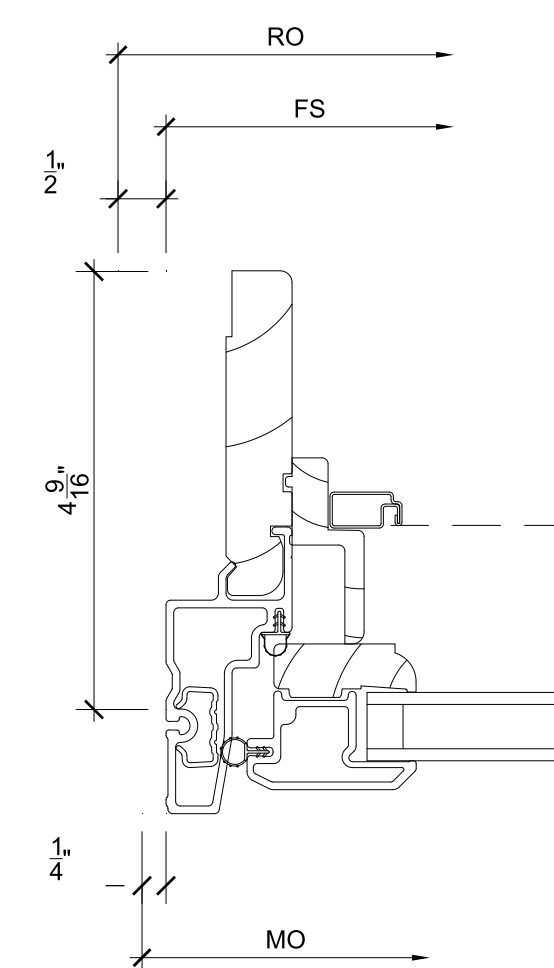

10
2 Jamb SCALE: 6" = 1'-0"

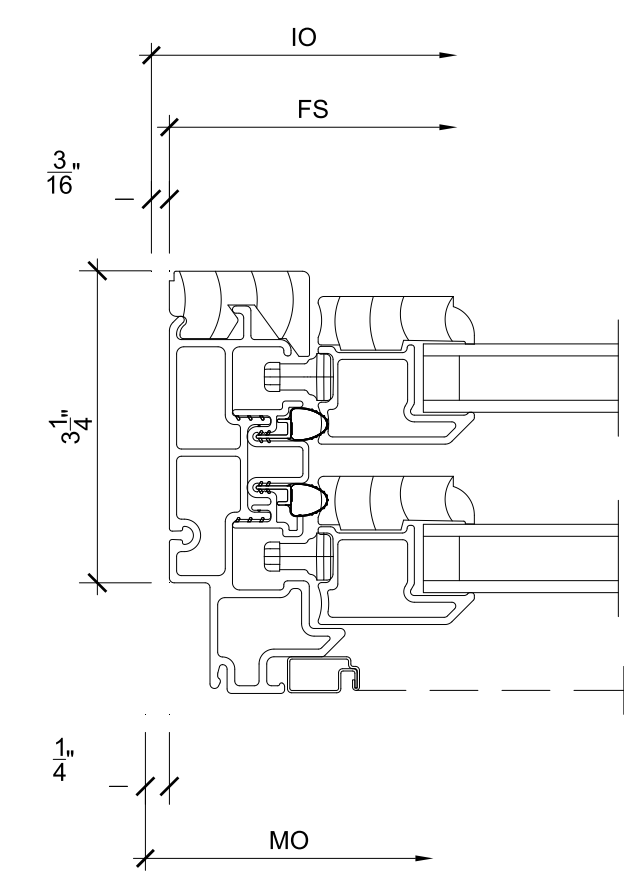

2
2 Jamb SCALE: 6" = 1'-0"

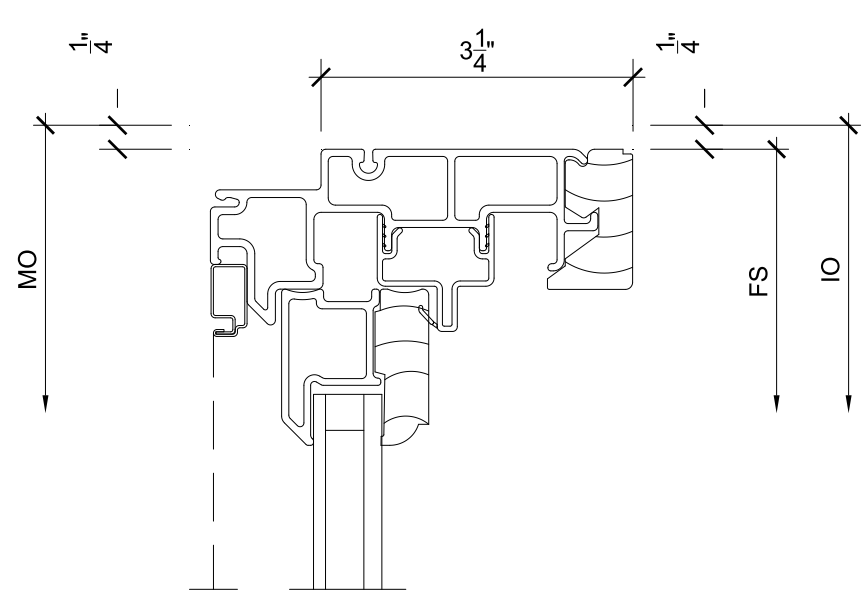

5
2 Head SCALE: 6" = 1'-0"

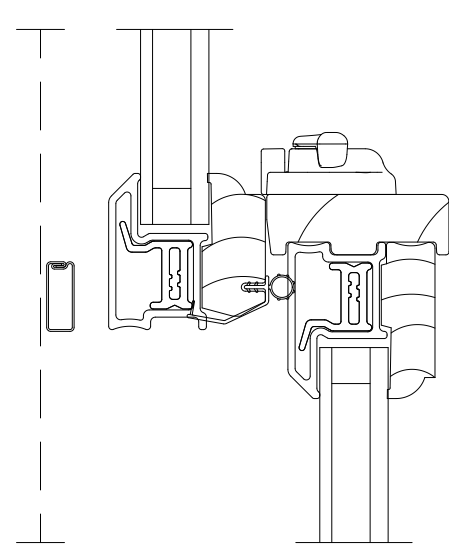

8
2 Check Rail SCALE: 6" = 1'-0"

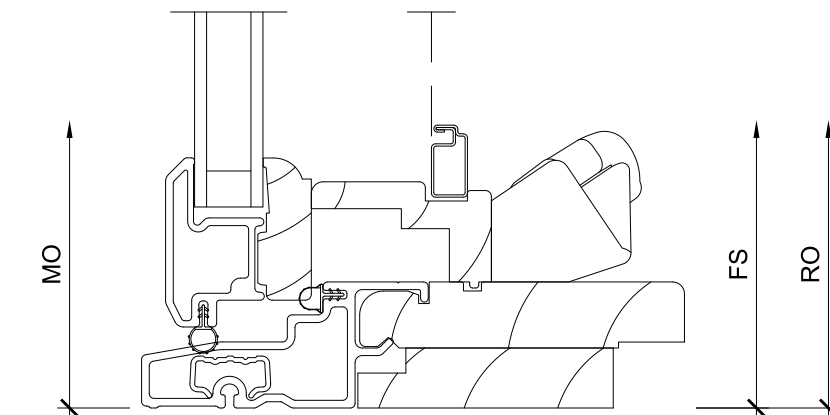

11
2 Sill SCALE: 6" = 1'-0"

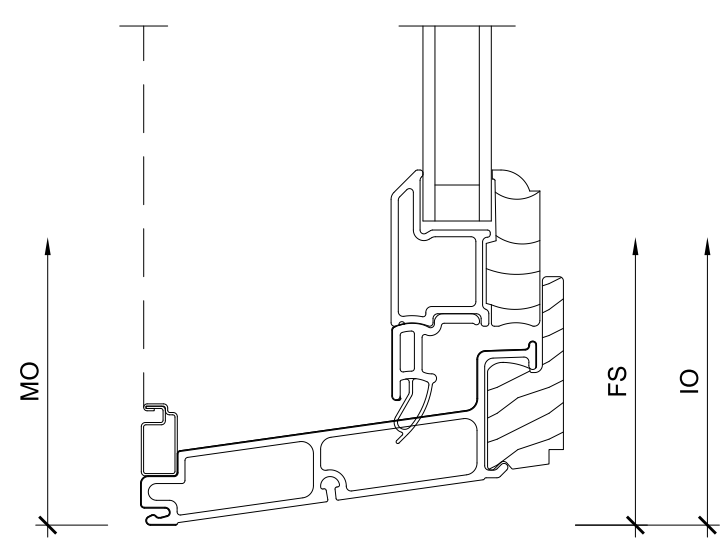

3
2 Sill SCALE: 6" = 1'-0"

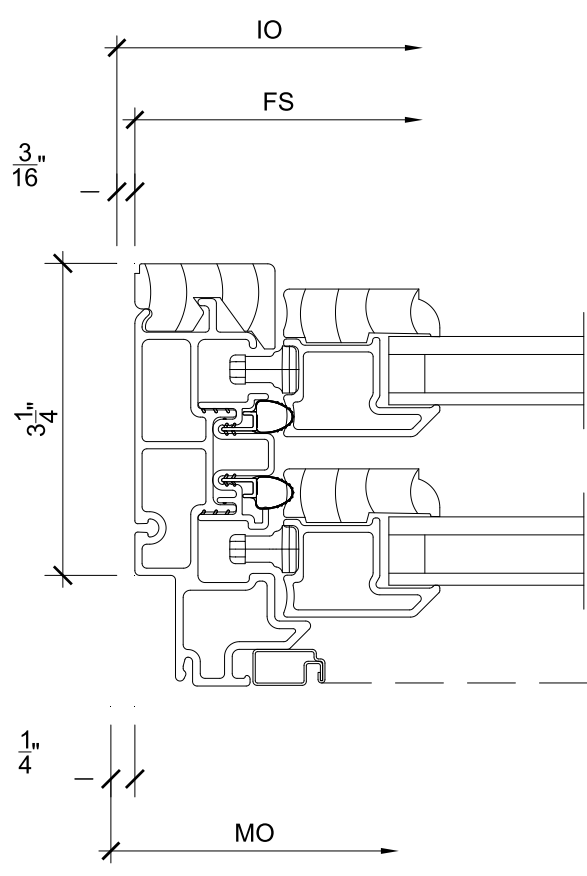

6
2 Jamb SCALE: 6" = 1'-0"

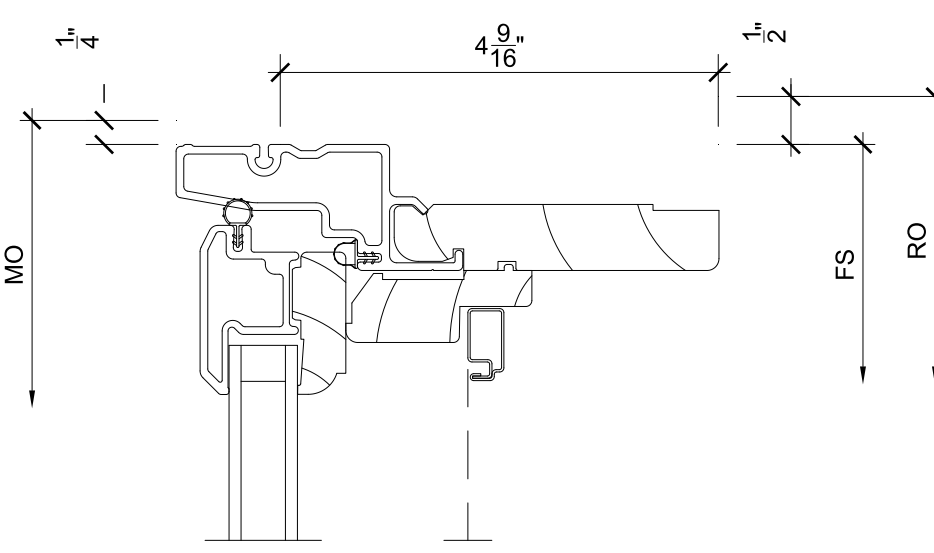

9
2 Head SCALE: 6" = 1'-0"

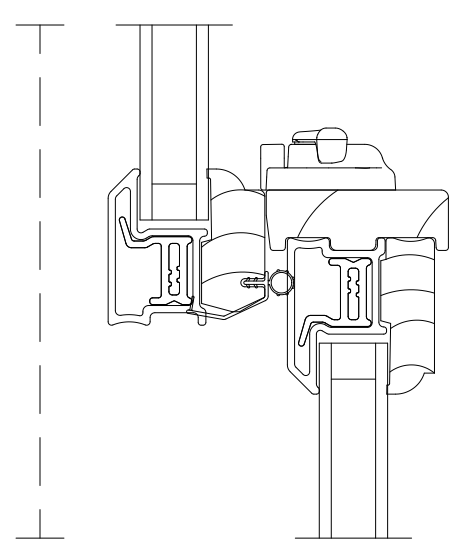

12
2 Check Rail SCALE: 6" = 1'-0"

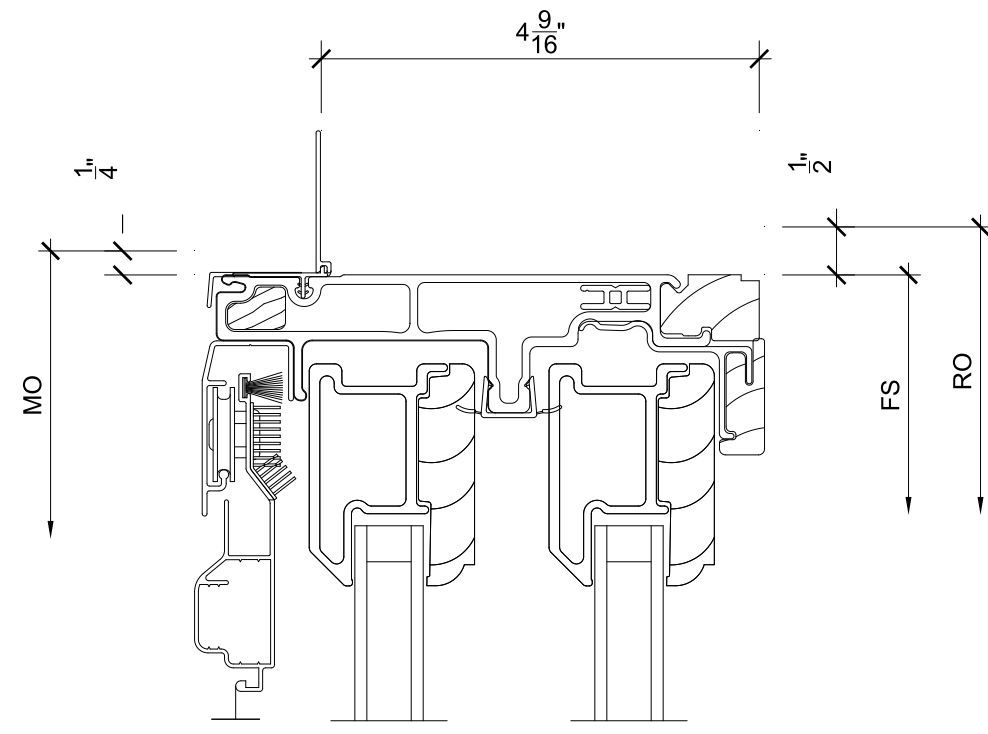

1
3 Head

SCALE: 6" = 1'-0"

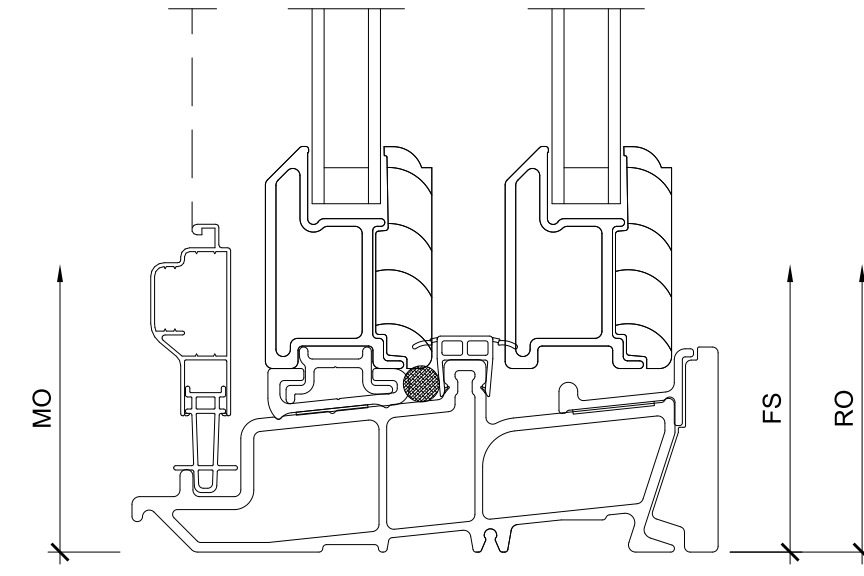

4
3 Sill

SCALE: 6" = 1'-0"

7
3 NOT USED

SCALE: 6" = 1'-0"

10
3 NOT USED

SCALE: 6" = 1'-0"

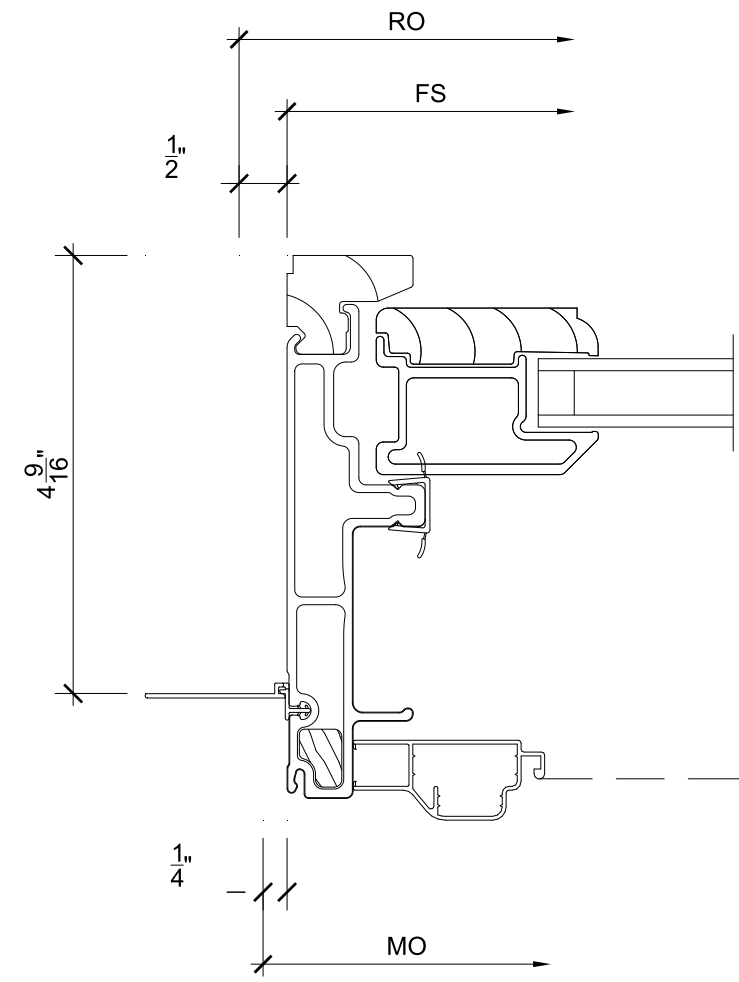

2
3 Jamb

SCALE: 6" = 1'-0"

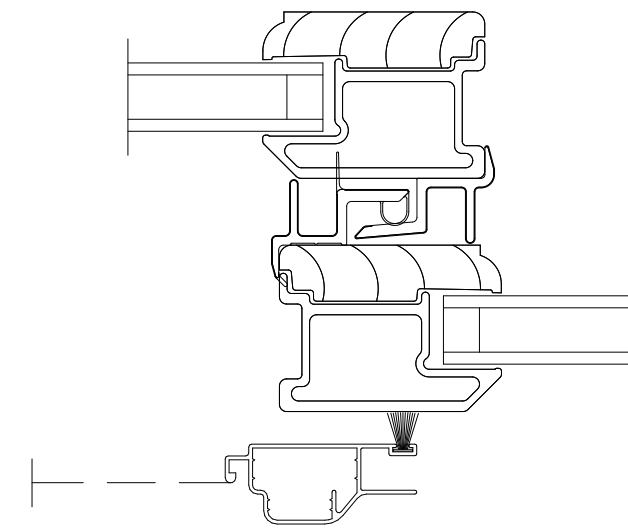

5
3 Meeting Stile

SCALE: 6" = 1'-0"

8
3 NOT USED

SCALE: 6" = 1'-0"

11
3 NOT USED

SCALE: 6" = 1'-0"

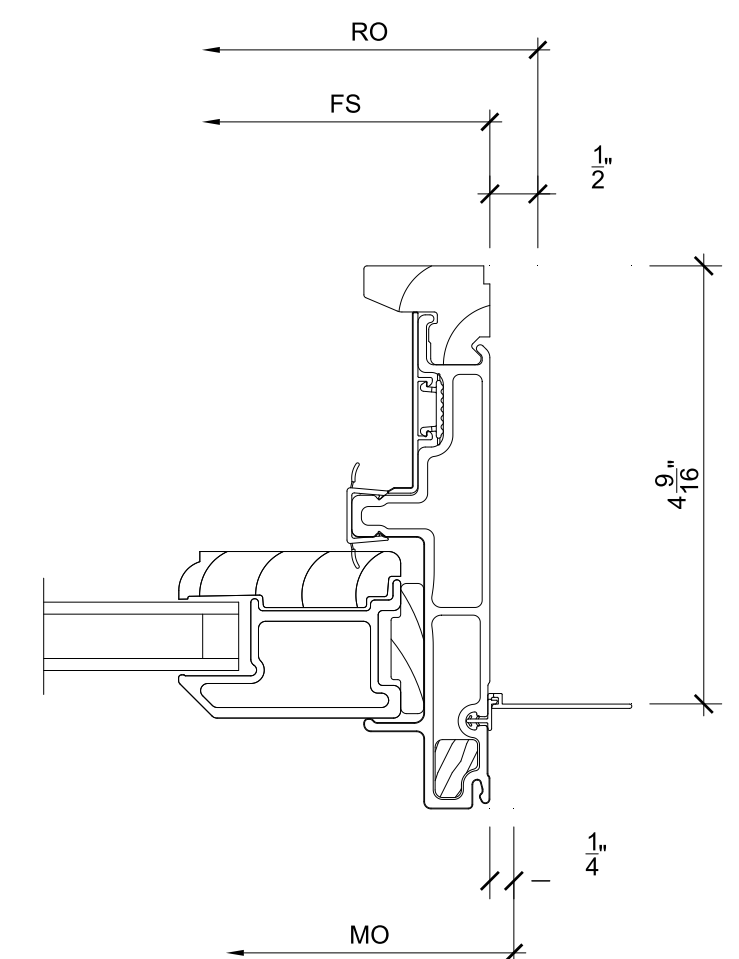

3
3 Jamb

SCALE: 6" = 1'-0"

6
3 NOT USED

SCALE: 6" = 1'-0"

9
3 NOT USED

SCALE: 6" = 1'-0"

12
3 NOT USED

SCALE: 6" = 1'-0"



ORDERING PRODUCTS WITH REFERENCE TO SHOP DRAWINGS:
Before ordering the Marvin Window and Door products illustrated within these shop drawings, a copy of these drawings accompanied by an approved signature of the purchaser must be returned to the Architectural Department, Marvin Windows & Doors, P.O. Box 100, Grand Rapids, Michigan 49503. The purchaser must also return a copy of these drawings to the approved shop drawings. Marvin Windows and Doors assumes no responsibility in guaranteeing product coordination with the drawings.

PROJ/JOB: Edelman / Schwartz / Bagley Project - Marvin Elevate
DIST/DEALER: LAURENCE SMITH DIST INC
DRAWN: CHRIS CASWELL
QUOTE#: GJ48R4N PK VERSION: 0003.15.00

SHEET
3
OF 3

CREATED: 07/22/2022 REVISION:

Quote Number:

Date:



Image is viewed from Exterior!

Customer Information

Name:

Address:

Phone 1:

Phone 2:

Fax:

Contact:

Job Name:

Specifications

U.D. = 31-1/2" x 79-13/16"; R.O. = 32-1/4" x 80-3/16"

O.M. of Exterior Trim = 34" x 81-1/16"

Lead Time: Stock (Call to verify)

Item Description	Qty
2' 6" x 6' 8" S206 Smooth-Star Fiberglass Door w/Clear Glass - Left Hand Inswing (Tru-Guard Composite Edge)	1
2-3/8" Backset - Double Bore (2-1/8" Dia. Bore w/Standard 5-1/2" Spacing) w/Mortised Edge Latch Preps w/Deadbolt Schlage (Standard) 1-1/8" x 2-3/4" Strike Prep	1
Set of T/T Ball-Bearing - Black Nickel Hinges	1
Dura-Frame - 4-9/16" Jamb w/Primed Brickmould Exterior Trim (Applied)	1
Bronze Compression Weatherstrip	1
ADA (Public Access) - Bronze Sill	1
Custom Cut 1" from Height	1



Discover a whole new
SIDE OF HOME.

HardiePlank®

Sleek and strong, HardiePlank® lap siding is not just our best-selling product – it's the most popular brand of siding in America.

With a full spectrum of colors and textures, homeowners can enjoy protection from the elements and the versatility to make their dream home a reality. From Victorians to Colonials, HardiePlank lap siding sets the standard in exterior cladding.

HardieTrim®
Boards
Arctic White

HardiePlank®
Lap Siding
Select Cedarmill®
Khaki Brown

A classic look for
THE HOME OF THEIR DREAMS.

HardiePlank®

Thickness 5/16 in
Length 12 ft planks

SELECT CEDARMILL® & SMOOTH

Width	5.25 in	6.25 in	7.25 in	8.25 in	9.25 in*
Exposure	4 in	5 in	6 in	7 in	8 in
Prime Pcs/Pallet	360	308	252	230	190
ColorPlus Pcs/Pallet	324	280	252	210	—
Pcs/Sq	25.0	20.0	16.7	14.3	12.5

SELECT CEDARMILL®



SELECT CEDARMILL®

Width	5.25 in	6.25 in	7.25 in	8.25 in	9.25 in*
STATEMENT COLLECTION™			✓	✓	
DREAM COLLECTION™	✓	✓	✓	✓	
PRIME	✓	✓	✓	✓	✓

SMOOTH



SMOOTH

Width	5.25 in	6.25 in	7.25 in	8.25 in	9.25 in*
STATEMENT COLLECTION™					
DREAM COLLECTION™	✓	✓	✓	✓	
PRIME	✓	✓	✓	✓	✓

BEADED CEDARMILL®



BEADED CEDARMILL® & BEADED SMOOTH

Width	8.25 in
Exposure	7 in
Prime Pcs/Pallet	240
ColorPlus Pcs/Pallet	210
Pcs/Sq	14.3

STATEMENT COLLECTION™	—
DREAM COLLECTION™	✓
PRIME	✓

BEADED SMOOTH

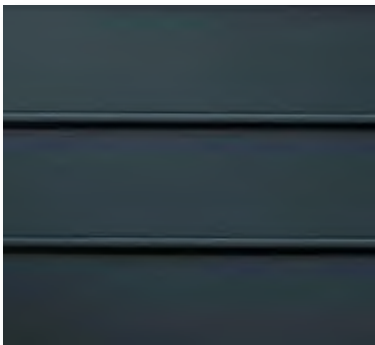

*9.25 in widths do not feature the drip edge

HardieTrim®

Form meets function at every angle with HardieTrim® boards. With an authentic look, HardieTrim boards provide design flexibility for columns, friezes, doors, windows and other accent areas.

Better than wood, it will complement your long-lasting, lower maintenance James Hardie® siding – adding punctuation to your design statement.

HardieTrim®
Boards
Khaki Brown

HardiePlank®
Lap Siding
Navajo Beige

The performance you require.

THE DISTINCTIVENESS YOU DESIRE.

HardieTrim®

Length 12 ft boards

ROUGHSAWN



SMOOTH

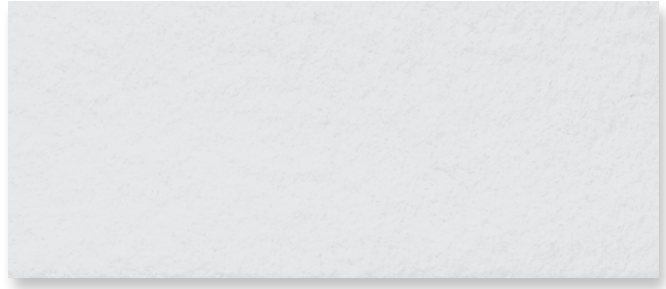

4/4 ROUGHSAWN

Thickness	.75 in				
Width	3.5 in	5.5 in	7.25 in	9.25 in	11.25 in
Prime Pcs/Pallet	312	208	156	104	104
ColorPlus Pcs/Pallet	312	208	156	104	104
STATEMENT COLLECTION™	AW	AW	✓	AW	AW
DREAM COLLECTION™	✓	✓	✓	✓	✓
PRIME	✓	✓	✓	✓	✓

4/4 SMOOTH

Thickness	.75 in				
Width	3.5 in	5.5 in	7.25 in	9.25 in	11.25 in
Prime Pcs/Pallet	312	208	156	104	104
ColorPlus Pcs/Pallet	312	208	156	104	104
STATEMENT COLLECTION™	AW	✓	✓	AW	AW
DREAM COLLECTION™	✓	✓	✓	✓	✓
PRIME	✓	✓	✓	✓	✓

5/4 ROUGHSAWN

Thickness	1 in					
Width	3.5 in	4.5 in	5.5 in	7.25 in	9.25 in	11.25 in
Prime Pcs/Pallet	240	200	160	120	80	80
ColorPlus Pcs/Pallet	240	200	160	120	80	80
STATEMENT COLLECTION™	✓		✓	✓	AW	AW
DREAM COLLECTION™	✓	✓	✓	✓	✓	✓
PRIME	✓	✓	✓	✓	✓	✓

5/4 SMOOTH

Thickness	1 in					
Width	3.5 in	4.5 in	5.5 in	7.25 in	9.25 in	11.25 in
Prime Pcs/Pallet	240	200	160	120	80	80
ColorPlus Pcs/Pallet	240	200	160	120	80	80
STATEMENT COLLECTION™	✓		✓	✓	AW	✓
DREAM COLLECTION™	✓	✓	✓	✓	✓	✓
PRIME	✓	✓	✓	✓	✓	✓

AW - Arctic White only. Not available in the standard trim product Statement Collection™ color offering.

BATTEN BOARDS

SMOOTH

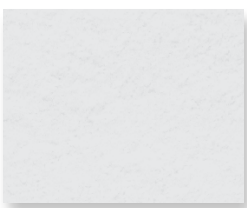

RUSTIC GRAIN®



SMOOTH & RUSTIC GRAIN®

Thickness	.75 in
Width	2.5 in
Prime Pcs/Pallet	190
ColorPlus Pcs/Pallet	437

STATEMENT COLLECTION™	✓
DREAM COLLECTION™	✓
PRIME	✓

HardieSoffit®

A home is only as strong as its weakest point. HardieSoffit® panels reinforce your work by protecting the vulnerable gap between eaves and exterior walls.

Available in vented, non-vented and a range of pre-cut sizes, these panels complete your design and help protect it from moisture and pests.

VENTILATION BENEFITS

Using vented soffit improves ventilation in the attic space and reduces the chance of water vapor condensation that can lead to issues such as mold and mildew growth, stained ceilings and damage to the framing of the house.

In warm climates, HardieSoffit panels allow hot, humid air to escape, which not only helps prevent condensation in the attic, but can also help reduce air conditioning costs.

In cool climates, HardieSoffit panels help prevent condensation from forming on the interior side of the roof sheathing and reduce the chances of roof-damaging ice dams.



HardieSoffit®
Panels
Dream Collection™
product

For complete confidence
EVERY DETAIL MATTERS.

HardieSoffit®

Thickness 1/4 in

VENTED SMOOTH & SELECT CEDARMILL®

Length	12 ft	12 ft	8 ft
Width	12 in	16 in	24 in
Prime Pcs/Pallet	200	150	100
ColorPlus Pcs/Pallet	216	156	108

VENTED SMOOTH

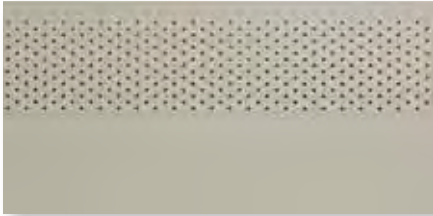

Size	12 ft x 12 in	12 ft x 16 in	8 ft x 24 in
------	---------------	---------------	--------------

STATEMENT COLLECTION™

DREAM COLLECTION™

PRIME

✓	✓	✓
✓	✓	✓

VENTED SELECT CEDARMILL®



Size	12 ft x 12 in	12 ft x 16 in	8 ft x 24 in
------	---------------	---------------	--------------

STATEMENT COLLECTION™

DREAM COLLECTION™

PRIME

✓		
✓	✓	✓
✓	✓	✓

NON-VENTED SMOOTH & SELECT CEDARMILL®

Length	12 ft	12 ft	8 ft	8 ft
Width	12 in	16 in	24 in	48 in
Prime Pcs/Pallet	200	150	100	50
ColorPlus Pcs/Pallet	200	150	100	–

NON-VENTED SMOOTH

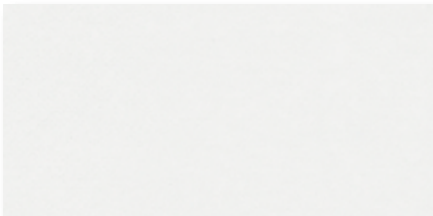

Size	12 ft x 12 in	12 ft x 16 in	8 ft x 24 in	8 ft x 48 in
------	---------------	---------------	--------------	--------------

STATEMENT COLLECTION™

DREAM COLLECTION™

PRIME

✓	✓	✓	
✓	✓	✓	✓

NON-VENTED SELECT CEDARMILL®



Size	12 ft x 12 in	12 ft x 16 in	8 ft x 24 in	8 ft x 48 in
------	---------------	---------------	--------------	--------------

STATEMENT COLLECTION™

DREAM COLLECTION™

PRIME

✓			
✓	✓	✓	
✓	✓	✓	✓

BEADED PORCH PANEL



Thickness	1/4 in
Length	8 ft
Width	48 in
Prime Pcs/Pallet	50
ColorPlus Pcs/Pallet	50

BEADED PORCH PANEL

STATEMENT COLLECTION™

DREAM COLLECTION™

PRIME

✓
✓

STATEMENT COLLECTION™

Make your next home stand out with our Statement Collection™ products. Carefully curated by our design experts specifically for your market, the collection brings together the most popular James Hardie ColorPlus® siding and trim styles, textures, and colors. This stunning selection is locally stocked and designed for simplicity - making it easier than ever to get a beautiful, long-lasting home exterior.

ColorPlus® Technology

Plank, Panel, Shingle and Batten Color Offering



Trim Color Offering

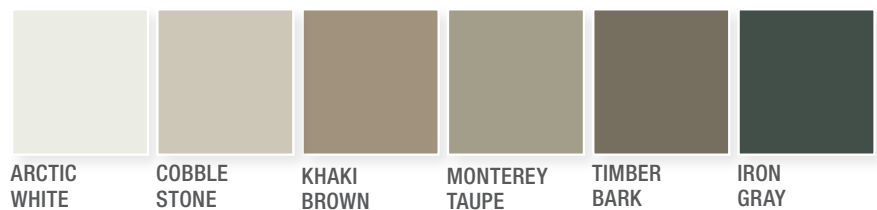

Soffit Color Offering

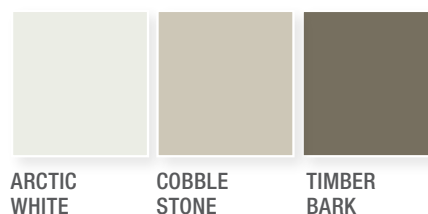

Colors shown are as accurate as printing methods will permit. Please see actual product sample for true color.

HardiePlank®

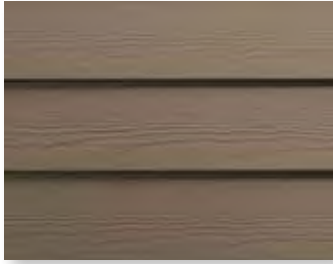

SELECT CEDARMILL®

Width 7.25 in 8.25 in
Exposure 6 in 7 in

HardiePanel®

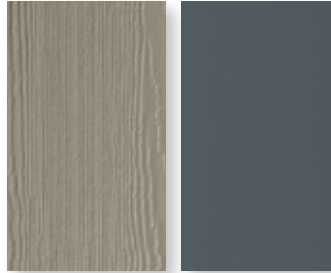

SELECT CEDARMILL® & SMOOTH

Size 4 ft x 10 ft

HardieShingle®



STRAIGHT EDGE PANEL

Height 15.25 in
Exposure 7 in



STAGGERED EDGE PANEL

Height 15.25 in
Exposure 6 in

HardieSoffit®



VENTED SELECT CEDARMILL®

Size 12 ft x 12 in



NON-VENTED SELECT CEDARMILL®

Size 12 ft x 12 in

HardieTrim®

4/4 SMOOTH



Thickness .75 in
Length 12 ft boards
Width 5.5 in 7.25 in
Widths in Arctic White only
3.5 in 9.25 in 11.25 in

4/4 ROUGHSAWN

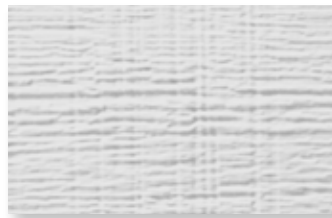

.75 in
12 ft boards
7.25 in
Widths in Arctic White only
3.5 in 5.5 in 9.25 in 11.25 in

5/4 SMOOTH



1 in
12 ft boards
3.5 in 5.5 in 7.25 in 11.25 in
Widths in Arctic White only
9.25 in

5/4 ROUGHSAWN

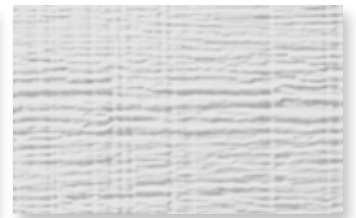

1 in
12 ft boards
3.5 in 5.5 in 7.25 in
Widths in Arctic White only
9.25 in 11.25 in

BATTEN BOARDS

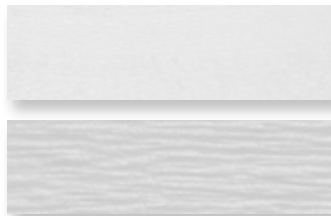

4/4 SMOOTH & RUSTIC GRAIN®

.75 in
12 ft boards
2.5 in



Selecting a color? Request a product sample at jameshardiepros.com/samples